



STB-6500

HD Commercial Interface Set-top Box

Commercial Mode Setup Guide

**Interactive Pro:Centric® •
Functionality**
RF or IP Content Delivery •

EXPERIENCED INSTALLER

First Use Wizard
pages 25 – 26

Custom Master STB Setup
pages 64 – 66

Cloning Procedures
pages 67 – 73

For Customer Support/Service, please call:

1-888-865-3026

The latest product information and documentation is available online at:

www.lg.com/us/business

MODEL and SERIAL NUMBER

The model and serial numbers of this STB are located on the back of the cabinet. For future reference, LG suggests that you record those numbers here:

Model No. _____ Serial No. _____



WARNING:

TO REDUCE THE RISK OF ELECTRIC SHOCK DO NOT REMOVE COVER (OR BACK). NO USER-SERVICEABLE PARTS INSIDE. REFER TO QUALIFIED SERVICE PERSONNEL.



The lightning flash with arrowhead symbol, within an equilateral triangle, is intended to alert the user to the presence of uninsulated "dangerous voltage" within the product's enclosure that may be of sufficient magnitude to constitute a risk of electric shock to persons.



The exclamation point within an equilateral triangle is intended to alert the user to the presence of important operating and maintenance (servicing) instructions in the literature accompanying the appliance.

WARNING:

TO PREVENT FIRE OR SHOCK HAZARDS, DO NOT EXPOSE THIS PRODUCT TO RAIN OR MOISTURE.

WARNING:

This product contains chemicals known to the State of California to cause cancer and birth defects or other reproductive harm. **Wash hands after handling.**

NOTE TO CABLE/TV INSTALLER:

This reminder is provided to call the cable TV system installer's attention to Article 820-40 of the National Electrical Code (U.S.A.). The code provides guidelines for proper grounding and, in particular, specifies that the cable ground shall be connected to the grounding system of the building, as close to the point of the cable entry as practical.

REGULATORY INFORMATION:

This equipment has been tested and found to comply with the limits for a Class B digital device, pursuant to Part 15 of the FCC Rules. These limits are designed to provide reasonable protection against harmful interference when the equipment is operated in a residential installation. This equipment generates, uses and can radiate radio frequency energy and, if not installed and used in accordance with the instruction manual, may cause harmful interference to radio communications. However, there is no guarantee that interference will not occur in a particular installation. If this equipment does cause harmful interference to radio or television reception, which can be determined by turning the equipment off and on, the user is encouraged to try to correct the interference by one or more of the following measures:

- Reorient or relocate the receiving antenna.
- Increase the separation between the equipment and receiver.
- Connect the equipment to an outlet on a circuit different from that to which the receiver is connected.
- Consult the dealer or an experienced radio/TV technician for help.

CAUTION:

Do not attempt to modify this product in any way without written authorization from LG Electronics U.S.A., Inc. Unauthorized modification could void the user's authority to operate this product.

COMPLIANCE:

The responsible party for this product's compliance is: LG Electronics U.S.A., Inc.
1000 Sylvan Avenue, Englewood Cliffs, NJ 07632, USA • Phone: 1-201-816-2000

Marketed and Distributed in the United States by LG Electronics U.S.A., Inc.
1000 Sylvan Avenue, Englewood Cliffs, NJ 07632

IMPORTANT SAFETY INSTRUCTIONS

1. Read these instructions.
2. Keep these instructions.
3. Heed all warnings.
4. Follow all instructions.
5. Do not use this apparatus near water.
6. Clean only with dry cloth.
7. Do not block any ventilation openings. Install in accordance with the manufacturer's instructions.
8. Do not install near any heat sources, such as radiators, heat registers, stoves, or other apparatus (including amplifiers) that produce heat.
9. Do not defeat the safety purpose of the polarized or grounding-type plug. A polarized plug has two blades with one wider than the other. A grounding-type plug has two blades and a third grounding prong. The wide blade or the third prong are provided for your safety. If the provided plug does not fit into your outlet, consult an electrician for replacement of the obsolete outlet.
10. Protect the power cord from being walked on or pinched, particularly at plugs, convenience receptacles, and the point where it exits from the apparatus.
11. Only use attachments/accessories specified by the manufacturer.
12. Use only with the cart, stand, tripod, bracket, or table specified by the manufacturer or sold with the apparatus. When a cart is used, use caution when moving the cart/apparatus combination in order to avoid injury from tip-over.



13. Refer all servicing to qualified service personnel. Servicing is required when the apparatus has been damaged in any way, such as power-supply cord or plug is damaged, liquid has been spilled or objects have fallen into the apparatus, the apparatus has been exposed to rain or moisture, does not operate normally, or has been dropped.
14. Never touch this apparatus or antenna during a thunder or lightning storm.
15. When mounting an STB on the wall, make sure that none of the electrical cabling bears any of the weight of the STB. Install in accordance with the manufacturer's instructions.

16. Power Cord

Caution: Check the STB specifications in the Owner's Manual to determine power requirements.

Periodically examine the cord of your appliance, and if its appearance indicates damage or deterioration, unplug it, discontinue use of the appliance, and have the cord replaced with an exact replacement part by an authorized servicer. Protect the power cord from physical or mechanical abuse, such as twisting, kinking, or pinching or being closed in a door or walked upon. Pay particular attention to plugs, wall outlets, and the point where the cord exits the appliance.

Do not use a damaged or loose power cord. Be sure to grasp the plug when unplugging the power cord. Do not pull on the power cord to unplug the STB.

Do not stick metal objects or any other conductive material into the power cord. Do not touch the end of the power cord while it is plugged in.

17. Overloading

Do not connect too many appliances to the same AC power outlet as this could result in fire or electric shock. Do not overload wall outlets. Overloaded wall outlets, loose or damaged wall outlets, extension cords, frayed power cords, or damaged or cracked wire insulation are dangerous. Any of these conditions could result in fire or electric shock.

18. Outdoor Use/Wet Location



Warning: To reduce the risk of fire or electrical shock, do not expose this product to rain, moisture or other liquids.

Do not touch the STB with wet hands. Do not install this product near flammable objects such as gasoline or candles or expose the STB to direct air conditioning.

Do not expose to dripping or splashing and do not place objects filled with liquids, such as vases, cups, etc., on or over the apparatus (e.g., on shelves above the unit).

19. Grounding

(Except for devices that are not grounded) Ensure that you connect the earth ground wire to prevent possible electric shock (i.e., an STB with a three-prong grounded AC plug must be connected to a three-prong grounded AC outlet). If grounding methods are not possible, have a qualified electrician install a separate circuit breaker. Do not try to ground the unit by connecting it to telephone wires, lightning rods, or gas pipes.

20. Disconnect Device

The power plug is the disconnecting device. The power plug must remain readily accessible.

As long as this unit is connected to the AC wall outlet, it is not disconnected from the AC power source even if the unit is turned off.

(Continued on next page)

IMPORTANT SAFETY INSTRUCTIONS

(Continued from previous page)

21. Outdoor Antenna Grounding

If an outside antenna or cable system is connected to the product, follow the precautions below.

An outdoor antenna system should not be located in the vicinity of overhead power lines or other electric light or power circuits or where it can come into contact with such power lines or circuits as death or serious injury can occur.

Be sure the antenna system is grounded so as to provide some protection against voltage surges and built-up static charges.

Article 810 of the National Electrical Code (NEC) in the U.S.A. provides information with respect to proper grounding of the mast and supporting structure, grounding of the lead-in wire to an antenna-discharge unit, size of grounding conductors, location of antenna-discharge unit, connection to grounding electrodes, and requirements for the grounding electrode.

Antenna Grounding According to NEC, ANSI/NFPA 70

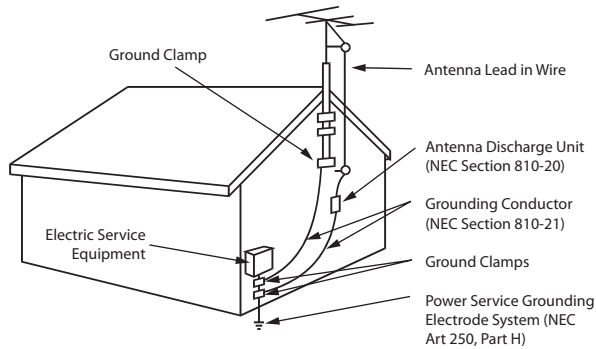

22. Cleaning

When cleaning, unplug the power cord and wipe gently with a soft cloth to prevent scratching. Do not spray water or other liquids directly on the STB as electric shock may occur. Do not clean with chemicals such as alcohol, thinners or benzene.

23. Transporting Product

Make sure the STB is turned Off and unplugged and that all cables have been removed. Do not press against or put stress on the STB.

24. Ventilation

Install the STB where there is proper ventilation. Do not install in a confined space such as a bookcase. Do not cover the STB with cloth or other materials (e.g., plastic) while it is plugged in. Do not install in excessively dusty places.

25. If you smell smoke or other odors coming from the STB or hear strange sounds, unplug the power cord, and contact an authorized service center.

26. Keep the product away from direct sunlight.

27. Do not install this product on a wall if it could be exposed to oil or oil mist. This may damage the product and cause it to fall.

28. Do not allow an impact shock or any objects to fall into the product.

29. Do not touch the ventilation openings, as they may become hot while the STB is operating. This does not affect the performance of the product or cause defects in the product.

30. Do not use high voltage electrical equipment near the STB (e.g., a bug zapper). This may result in product malfunction.

Table of Contents

Safety Warnings	2	Navigating Within the Installer Menu	51
Important Safety Instructions	3–4	Modifying Installer Menu Settings.	51
Table of Contents	5	Exiting the Installer Menu and Activating Settings	51
STB-6500 Introduction / Setup Checklist.	7	Detailed Descriptions of Installer Menu Items	54
Introduction	7	Custom Master STB Setup	64–66
Setup Checklist	7	Before You Begin	64
STB-6500 Cabling Connections	8–12	Clonable STB Setup Menu Features	64
Before You Begin	8	Custom Master STB Setup Procedure	65
Connect the STB to the Display Panel	9	Cloning Procedures	67–73
STB-6500 Cabling Diagram	12	Exporting a Clone File	67
Commercial Mode Overview	13–18	Importing a Clone File.	69
Pass-through Mode.	13	Cloud Configuration Tool Overview	74–80
FTG Mode.	15	Creating an FTG Configuration File	74
Application Tuning Mode / Pro:Centric Direct.	17	File Manager Web Page Overview.	78
Determining the STB Operating Mode	18	Channel Map Web Page Overview.	79
Pro:Centric Operation	19–23	Installer Menu Web Page Overview	80
Interactive Menu Features	19	IP Environment Setup	81–98
Interactive Menu Navigation	19	Accessing the IP Environment Menu	81
Pro:Centric Java Application Setup	22	Network Configuration	81
Pro:Centric Direct HTML Application Setup	22	Pro:Centric Setup	87
Setting the Video Output Resolution	24	General Options	91
First Use Wizard	25–26	Portal Settings.	93
Before You Begin	25	Media Share Setup	95
Initiate Configuration or Exit the First Use Wizard	26	References	
Basic Settings Wizard	27–31	Updating STB Software using a USB Memory	
Solution Settings / EZ-Manager Wizard	32–44	Device.	99–100
STB Configuration Options	32	Downloading Images or Icons using a USB Memory	
Zones and Room Number Assignments.	33	Device.	101–103
Network Settings.	34	Downloading a Hotel Video using a USB Memory	
Pro:Centric Settings	37	Device.	104–106
Standard Pro:Centric Server Configuration	37	Downloading a Pro:Idiom Media Key using a USB	
Pro:Centric Cloud Server Configuration	42	Memory Device.	107
USB Configuration	43	Display Panel Specifications	108
Ez Download Utility	45–49	STB Aux Input Configuration	109
Before You Begin	45	Auto Input(s) Sensing Feature	110–111
Accessing and Using the Ez Download Utility	46	Enabling or Disabling the MTI Protocol on the STB	112–113
Installer Menu	50–63	Restoring Factory Defaults on the STB(s).	114
Accessing the Installer Menu	50	Using the STB’s Zoning Features	115–118
		Using Media Share Features	119–121

Notes

- Installer Menu content is intended for use primarily by qualified TV installation technicians.
- Refer to the STB-6500 Owner’s Manual for additional information on STB installation, specifications, maintenance, and safety instructions.
- Design and specifications subject to change without prior notice. This document provides examples of typical screen displays. Your displays may vary from those shown in this document.

Table of Contents (Cont.)

STB-6500 Jack Panels	122
External IR Receiver Specifications	123
External Audio Line Out Specifications	124
Installer Remote Typical Key Functions	125
LG Slate-RX Lodging Remote	126–127
TLT Communication Parameters	128–135
Troubleshooting	136–138
General Troubleshooting	136
STB Quick Check	137
Commercial Mode Check	138
Glossary of Terms	139
Document Revision History / Open Source Software	
Notice	140
Back Cover	141

STB-6500 Introduction / Setup Checklist

Introduction

The STB-6500 set-top box is designed to be connected to a compatible commercial display panel to create a system that provides Pro:Centric[®] functionality via RF or IP and that can tune RF and IP content. The STB-6500 may be used with LG Commercial Hospitality TVs (LW570H, UW660H, etc.) that support Multiple Protocol Interface (MPI), or the STB-6500 may be used with LG Commercial Public Display TVs (LV340H, UT340H, etc.) or LG Commercial Monitors (M3203CCBA, M3204C, etc.) that support the TV-Link Monitor (TLM) interface. The STB-6500 may also be used with commercial non-LG TVs that support SONIFI's Multiple Television Interface (MTI) protocol.

Setup Checklist

See also the STB-6500 Owner's Manual for information on STB installation and hardware and cable connections.

Installation and Setup

___ Unpack the STB and all accessories.

Accessories provided:

- Power cord & AC/DC Adapter
- HDMI Cable
- MPI/MTI Cable (proprietary cable for LG MPI or SONIFI MTI control of display panel)
- TLM Cable (proprietary cable for LG TLM control of display panel)
- A/V Adapter Cable

___ Obtain an LG Installer Remote for configuration purposes.

If you are connecting the STB to an LG display panel, the LG remote provided with the display should be sufficient. If you are connecting the STB to a non-LG display panel or if you intend to use multiple STBs/displays in a single room installation environment, an LG Slate-RX remote control that provides full Installer Remote functionality and also is capable of supporting LG multi-code IR (Bed) settings is available for purchase. For additional information and/or to purchase a Slate-RX remote, contact your LG Sales representative or distributor. See also Reference section, "LG Slate-RX Lodging Remote."

___ Determine the installation location for the STB and display panel stand or mount.

___ Determine mounting and installation requirements, for example, AC power source outlet, antenna/cable service connectors, any external equipment required for system operation, all necessary cables, wires, and connectors, and any other additional required hardware, etc.

___ Install the display panel on VESA mount or stand. Note that it may be advisable to make all cable connections before installing on VESA mount or stand.

Hardware Connections

___ Install any additional hardware as appropriate to your institution, LAN, etc.

Cable Connections

___ Make all required connections to the STB jack panels, as described in this document.

Commercial Mode Setup

___ Complete appropriate procedures as described in this document for Commercial Mode operation.

STB-6500 Cabling Connections

This section describes how to connect the STB-6500 to establish communication with a compatible commercial display panel (LG Hospitality TV, LG Public Display TV, LG Commercial Monitor, or commercial non-LG TV with MTI support).



Caution: If you are replacing an existing/currently installed display panel, you cannot simply swap out one display panel for another. You must follow the procedure below from step 1 in order to establish Television/Display Control communication between the STB and the new display panel. Make sure to connect the HDMI cable from the STB to the same numbered HDMI input on the new display panel as it was connected to on the previous display panel). Also, make sure the new display panel supports the video output resolution set in the STB. Note that you may need to change the STB setting (STB Installer Menu item 105 VID OUT FORMAT) as required.

Before You Begin

Refer to the appropriate subsection(s) below before proceeding to connect the STB. In particular, make sure each display panel is in the proper, known state.

LG Display Panel Prerequisites

- The display panel should be in a known state. That is, the display panel should be either in a factory default state or custom configured (in its default mode) with selected settings, for example, the aspect ratio, that you wish to use in conjunction with the STB.
- For newer LG Public Display TVs, when you power ON the TV for the first time, a Welcome Wizard will be displayed, and you will need to complete the first two steps of the wizard before you can successfully connect the STB. First, you will need to select the Language (Step 1), and then you will need to select the Mode Setting (Step 2). For Step 2, you MUST select “Home Use.” After this, you can either continue with the wizard and select additional desired configuration settings, or you can use the EXIT key on the remote to exit the wizard.

Commercial Non-LG Display Panel Prerequisites

- The display panel must be in a known state; however, note that you may need to perform initial steps to configure the display (i.e., the TV) and/or its MTI port for MTI communication. Refer to the manufacturer’s documentation for further information.

Note: You also will need to perform steps to enable the MTI protocol (disabled by default) on the STB as part of the Commercial Mode setup AFTER the STB is connected to the display panel. See Reference section, “Enabling or Disabling the MTI Protocol on the STB” for further information. In order to complete these steps, you need to see the STB’s HDMI video output. Use the display panel’s IR remote to manually switch the display panel to the appropriate HDMI input.

- It is highly recommended that you set the display’s start channel/Power On source to HDMI 1 since, when Television/Display Control communication is established, the STB default configuration automatically sends Television/Display Control commands to switch the connected display panel to its HDMI 1 input. Because some non-LG displays default to an RF channel at turn ON (or at loss of communication), setting the display’s Power On source to HDMI 1 will eliminate the potential for the display’s momentary interruption of the STB’s HDMI output each time the STB/display is turned ON. This will also eliminate the potential for temporary signal interruption from the STB when the STB’s PTC software is being updated.

LG Installer Remote

- An LG Installer Remote (not supplied) is required to complete the procedure below, as well as STB/display panel configuration procedures in this document. If you are connecting the STB to an LG display panel, the LG remote provided with the display should be sufficient. However, if you are connecting the STB to a non-LG display panel or if you would like to take advantage of the STB's multi-code feature, LG's Slate-RX remote control will be required. See Reference sections, "Installer Remote Typical Key Functions" and "LG Slate-RX Lodging Remote," for further information.

Connect the STB to the Display Panel

This procedure only describes the essential STB/display panel connections. See Reference section, "STB-6500 Jack Panels," for further information on the additional jack panel ports and connectors.

1. Make sure the STB is not connected to power. If a display panel is being replaced in an existing STB/display panel installation, remove power from the STB.
2. Turn ON the display panel.
3. Refer to the STB-6500 Cabling diagram on page 12, and complete the following connections:
 - a) Make the appropriate Television/Display Control connection between the STB-6500 and the display panel.
 - For LG Hospitality TVs: Use the MPI/MTI cable provided to connect MPI/MTI TELEVISION CONTROL on the STB-6500 front jack panel to the MPI port on the rear jack panel of the display.
 - For LG Public Display TVs or LG Commercial Monitors: Use the TLM cable provided to connect RS-232C TELEVISION CONTROL on the STB-6500 rear jack panel to the DB9 RS-232 CONTROL connector on the rear jack panel of the display.
 - For commercial non-LG TVs: Use the MPI/MTI cable provided to connect MPI/MTI TELEVISION CONTROL on the STB-6500 front jack panel to the MTI (typically labeled "DATA") port on the rear jack panel of the display.*

Note: Commercial interfaces and their respective cables (MPI/MTI or TLM as specified above) support IR pass-through.

- b) Use the HDMI cable provided to connect HDMI OUT on the STB-6500 rear jack panel to the HDMI 1 input connector on the rear jack panel of the display (see also notes below).

Note: When Television/Display Control communication is established, the STB default configuration automatically sends Television/Display Control commands to switch the connected display panel to its HDMI 1 input.

Note: If this is a new display panel in an existing STB/display panel installation, connect the HDMI cable from the STB to the same HDMI input on the new display panel that it was connected to on the previous display panel, in accordance with the current value of Installer Menu item 100 VIDEO INTERAC. That is, if the HDMI cable was connected to HDMI 2 on the previous display panel, connect the HDMI cable to HDMI 2 on the new display panel.

(Continued on next page)

* As indicated in the prerequisites, the MTI protocol required for communication between the STB and the commercial non-LG display panel is disabled by default. Remember that you will need to enable the MTI protocol as part of the Commercial Mode setup.

STB-6500 Cabling Connections (Cont.)

(Continued from previous page)

- c) For RF delivered content, connect a 75 ohm coaxial wire from the Antenna/CATV wall jack to ANTENNA/CABLE IN on the STB-6500 rear jack panel. For IP delivered content, connect an RJ-45 Ethernet (CAT5) cable from the institution's network to the LAN port on the STB-6500 rear jack panel.
- d) Insert the DC power plug of the AC/DC power adapter provided into the POWER connector on the rear jack panel of the STB-6500, and then plug the AC/DC adapter into a standard 120V 60 Hz AC power outlet.

When power is applied to the STB-6500, the LED on the STB's front jack panel turns red (steadily if the STB is in its default standby power state or with a blink every five seconds in accordance with the current value of Installer Menu item 002 AC ON).

Also, for LG display panels or if the MTI protocol has already been enabled on the STB (i.e., you are replacing one non-LG display panel with another non-LG display panel), the display panel will be turned OFF by the STB as soon as the STB is powered and establishes Television/Display Control communication with the display.*

Note: Once Television/Display Control communication is established between the STB-6500 and the display panel, the STB-6500 will be in control of the display panel, and certain resident panel functions, like panel buttons, typically will no longer operate.

Note: If connected to an LG Hospitality TV, the STB also will change several of the TV's Installer Menu settings in order to facilitate communication and functionality. See the table following this procedure for a listing of all Hospitality TV Installer Menu items that will be changed by the STB.

4. Use the Installer Remote to turn ON the STB/display panel.

In its default standby power state, while turning ON and sending the turn ON command to the display panel, the STB LED blinks at a constant rate. In this scenario, once both the STB and the display panel are ON, the STB LED remains lit but blinks off twice in rapid succession every five seconds. When the Instant ON feature set with Installer Menu item 002 is enabled on the STB, the turn ON blink duration may be shorter.

If the STB is brand new, out-of-box, the first image you should see on the display panel is a prompt to select the video output resolution (see "Setting the Video Output Resolution" on page 24). If the STB is not brand new, out-of-box, it is possible that the video output resolution has previously been set and/or that the First Use Wizard has previously been completed or exited.**

5. If applicable, select the video output resolution (i.e., the STB's video output format), and then complete the appropriate Commercial Mode setup procedures, as described in this document.

Note: It is recommended that you complete STB-6500 Commercial Mode setup procedures before you make external equipment connections to the STB-6500.

* If the display panel is not turned OFF after power is applied, then Television/Display Control communication has not been established. If you are using an LG display panel, check that the display is in a known state, and repeat the procedure from step 1. If you are using a commercial non-LG TV as a display panel in a new STB installation, the display panel will not be turned OFF because the MTI protocol has not yet been enabled. Remember that you will need to enable the MTI protocol as part of the Commercial Mode setup.

** If you are using a commercial non-LG TV as the display panel, and you do not see video on the display, verify the display panel is on the appropriate HDMI input so that you can complete step 5. Also, see Reference section, "Enabling or Disabling the MTI Protocol on the STB," and make sure to enable the MTI protocol as part of the Commercial Mode setup.

STB-6500 Cabling Connections (Cont.)

The following table is only valid for LG Hospitality TVs that are used with the STB-6500. The table lists the Installer Menu items on the TV that are changed by the STB when MPI Television/Display Control communication is established. See also step 3 of procedure above.

Note: The total number of Installer Menu items may vary by Hospitality TV model. Some items listed below are not available on/applicable for all Hospitality TVs.

Installer Menu Item on LG Hospitality TV (Display Panel)	STB-6500 will set the value to:	Comments
004 STRT CHANNEL	0	Start channel on the display is set to Aux.
007 STRT VOLUME	63	Based on the setting of STB Installer Menu item 111 PANEL VOL PRE. Maximum setting is recommended.
008 MIN VOLUME	0	Minimum allowable volume is set on the display.
009 MAX VOLUME	63	Maximum allowable volume is set on the display.
040 AUTO CAMPORT	0	Automatic switching to Camport (Video 2) is disabled on the display.
041 SIMPLINK EN	0	SIMPLINK is disabled on the display.
042 AUTO INPUTS	0	Auto-sensing is disabled for all Aux inputs on the display.
046 STRT AUX SRCE	3 (HDMI 1) 5 (HDMI 2) 7 (HDMI 3)	Based on the setting of STB Installer Menu item 100 VIDEO INTERFAC (see detailed Installer Menu item descriptions). By default, the display's start Aux source is set to HDMI 1.
047 AUX STATUS	1	The display's Aux source will be reported as a channel number.
053 DIS. CH-TIME	1	The display's native Channel-Time display is disabled.
090 KEY LOCK	1	Key Lock is enabled on the display. If item 090 is changed in the STB's Installer Menu, the STB will update the value in the display's Installer Menu accordingly.
096 DEF. ASP. RATIO	3	The display's default aspect ratio will be set to Just Scan.
118 POWER SAVINGS	1	b-LAN module is always powered on the display.
119 DATA CHANNEL	0	Data Channel is disabled on the display.

STB-6500 Cabling Connections (Cont.)

STB-6500 Cabling Diagram

See also step 3 of procedure above.

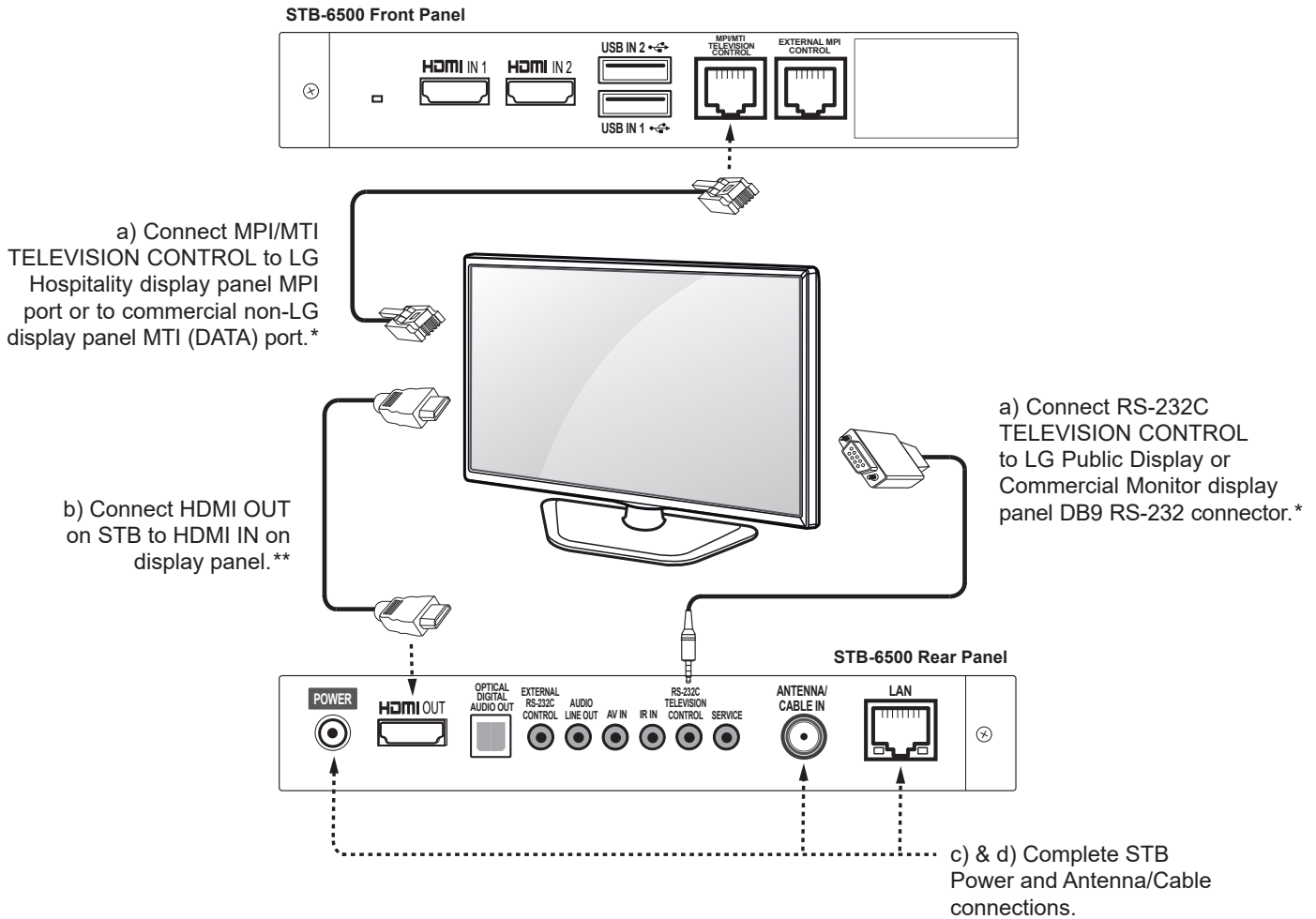

* Only one Television/Display Control connection should be used. The proper connection depends on the type of display panel to be controlled.

** The STB default configuration automatically sends Television/Display Control commands to switch the connected display panel to its HDMI 1 input.

This document describes how to set up the STB-6500 for Commercial Mode operation. STB-6500 functionality is based on “ownership” of the Channel Map; that is, the Channel Map resides in the STB’s CPU or Protocol Translation Controller (PTC), or it resides in a Pro:Centric application or an external device from the solution provider.

The STB-6500 supports several different operational modes: LG’s Free-To-Guest (FTG) Mode via the STB CPU, Application Tuning Mode (ATM) with Pro:Centric application, or Pass-through Mode (default). In several operational modes (Pass-through, FTG Mode via CPU, and Application Tuning Mode), the STB-6500 may also be externally controlled via Multiple Protocol Interface (MPI) or TV-Link Tuner (TLT) interface (RS-232C).*

Pass-through Mode

This mode allows you to configure individual STBs for Pro:Centric and/or FTG Mode operation. This mode also allows external control via either the STB’s EXT MPI CONTROL port or EXTERNAL RS-232C CONTROL port.

There are several methods for configuring individual STBs that are currently in Pass-through Mode: either one of the First Use Wizard options or using the Custom Master STB Setup procedure.

First Use Wizard

When the STB is in a factory default state, the First Use Wizard provides three guided setup options:

- Basic Settings: Configuration of basic settings, including language & location, network settings, etc.
- Solution Settings (default): EZ-Manager Wizard configuration for Pro:Centric operation.
- IP Environment Settings: Configuration of network settings, manual Pro:Centric settings, etc. via the IP Environment Menu.

See “First Use Wizard” on pages 25 to 26 for further information.

Custom Master STB Setup

The Custom Master STB Setup procedure enables you to create a customized Master STB Setup for Pass-through Mode or FTG Mode configuration purposes. Use the Installer Remote to configure Installer Menu items as required for STB operation and set up STB features (Channels, Picture, Sound, etc.). See “Custom Master STB Setup” on pages 64 to 66 for detailed information.

Installer Menu

To create a Master STB Setup, you will need to know how to access the commercial controller (PTC) Installer Menu and make changes to the default values as required. If necessary, familiarize yourself with the Installer Menu and how to make and save changes. See pages 50 to 63 for information on accessing the Installer Menu and for detailed descriptions of the Installer Menu items. See also example on following page.

* MPI is an LG proprietary control protocol; you will need to sign a non-disclosure agreement (NDA) in order to obtain the MPI interface, timing, and syntactical command set specification.

Commercial Mode Overview (Cont.)

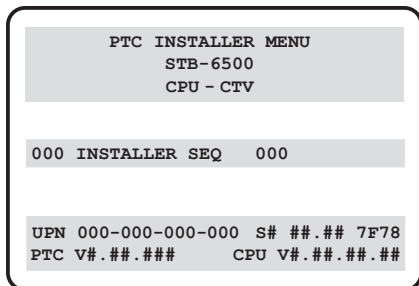

STB Setup Menus

On-screen setup menus control the features of the STB/display. Use the Installer Remote to access the STB setup menus, and set the STB/display features to the desired configuration for the end user. See examples below.

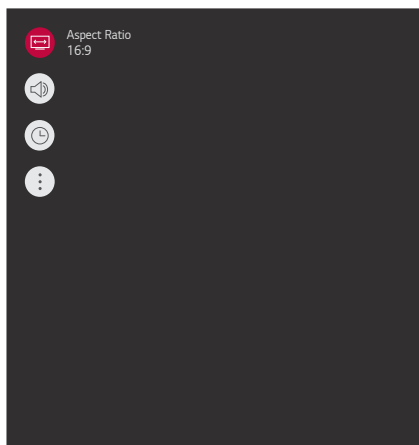

STB Setup Menus (Quick Settings)

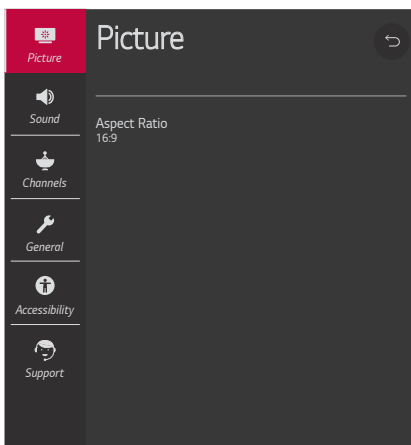

STB Setup Menus (Advanced Settings)

Cloning

Cloning refers to the process of using a Master STB Setup to configure a Target STB. Both STBs must be identical models. The Master STB's clonable setup menu features should be configured as part of the Master STB Setup. If there are features in the Master STB's setup—channel icons or labels, digital font options, etc.—that are not set or that are set incorrectly, those features also will not be set or will be set incorrectly in the Target STBs. See pages 67 to 73 for detailed information on Clone (.tlx) files and cloning requirements and procedures.

External MPI Control

Installer Menu item 030 EXTCTL/ACKMASK determines the availability of external control in accordance with the mode in which the STB is currently operating. See bullets below as well as Installer Menu item 030 description on page 58 for details.

- To control the STB using an external MPI control device, you must use the STB's EXT MPI CONTROL port for communication purposes.

Note: When the STB is in Pass-through/CPU-CTV Mode, item 030 is set to 0 or 1, and an MPI device functioning in "loop" mode is connected to the STB, the STB will go into MPI-EXT Mode, and TLT external control automatically will be blocked.

- To control the STB using an external TLT control device, you must use the STB's EXTERNAL RS-232C CONTROL port for communication purposes. See Reference section, "TLT Communication Parameters," for further information.

FTG Mode

In this mode, the STB's CPU is configured with an FTG Channel Map, and the CPU controls and restricts the tuning operation of the STB based on this FTG Channel Map. The FTG Channel Map enables the decryption of each Pro:Idiom[®] encrypted channel and also provides logical channel mapping of physical RF channels (digital and analog), IP streams, and Aux inputs. In addition, depending on the types of channels included in the FTG Channel Map, FTG Mode also provides the option to select either logical or physical tuning (see notes below) during configuration.

Note: Logical channel mapping of physical RF channels eliminates dash tuning; for example, physical 19-3 can be mapped to logical channel 9. It also allows physical RF channels, IP streams, and Aux inputs to be listed in any order, not only in physical numeric ascending order. Physical channel tuning requires that you include the dash when direct entering RF channel numbers and Aux inputs (the latter designated by 130-0 through 137-0).

Note: Physical channel tuning is not available when IP channels are included in the FTG Channel Map.

FTG Mode Features

FTG Mode provides the following features:

- Logical or physical channel tuning of physical RF channels and Aux inputs.
- Logical channel tuning of IP streams.
- Mapping of RF channels with minor (program) numbers up to 999.
- FTG Channel Map of up to 600 channels.
- Start Channel set for RF, Aux input, or IP delivered content.
- Pro:Centric data delivery over RF or IP.
- STB Zoning (including channel restrictions by Zone) and Wi-Fi Zoning options for location-specific configuration.
- External control via either the STB's EXT MPI CONTROL port or EXTERNAL RS-232C CONTROL port.

Commercial Mode Overview (Cont.)

LG's Cloud Configuration Tool enables you to create an FTG Configuration (.tlx) file, which may be used to configure the CPU for FTG Mode. Configuration utilities enable you to create/edit an FTG Channel Map and configure Installer Menu settings. You can also create a Clone (.tlx) file from a Master STB Setup that may be used to configure the CPU for FTG Mode.

Note: STB Zoning and Wi-Fi Zoning features are supported via ".tlx" file. See Reference section, "Using the STB's Zoning Features," for further information.

In this mode, the STB's CPU must be configured with an FTG Channel Map and FTG Installer Menu settings using one of the following processes:

- Local: Configure an individual STB-6500 via its USB port using a USB memory device / ".tlx" file. The file may be either a Clone file (see "Cloning Procedures" on pages 67 to 73) or an FTG Configuration file (see "Cloud Configuration Tool Overview" on pages 74 to 80).
- Remote: Configure all STB-6500s at the site using a Pro:Centric server head end device (Example: PCS500R). Refer to the **Pro:Centric Server Admin Client User Guide** for further information.

While the STB is in FTG Mode:

- The Installer Menu is still accessible using an LG Installer Remote; however, all Installer Menu items will be read-only.
- FTG Mode configuration changes must be made using a ".tlx" file (typically edited in the Cloud Configuration Tool). Channel Map and Installer Menu configuration utilities enable you to make changes, respectively, to the FTG Channel Map and FTG Installer Menu settings as necessary. See information on local configuration in this document or refer to documentation for the server for information on remote management.
- If it becomes necessary to restore the STB to Pass-through Mode, there are several options that will enable you to do so. See Reference section, "Restoring Factory Defaults on the STB(s)," for further information.

Pages 74 to 80 provide overviews of the utilities that comprise the Cloud Configuration Tool. Refer to the **Cloud Configuration Tool User Guide** for further details on the Cloud Configuration Tool.

Remote Management

When the STB is configured for FTG Mode, remote management of the FTG Channel Map and FTG Installer Menu settings is provided by a Pro:Centric server, via a Clone/Configuration (.tlx) file loaded on the Pro:Centric Admin Client. See the **Pro:Centric Server Admin Client User Guide** for further information.

External Control

Installer Menu item 030 EXTCTL/ACKMASK determines the availability of external control in accordance with the mode in which the STB is currently operating. See bullets below as well as Installer Menu item 030 description on page 58 for details. External control is prohibited by default in FTG Mode. Set item 030 to allow external control via (only) one of the applicable ports.

- To control the STB using an external MPI control device, you must use the STB's EXT MPI CONTROL port for communication purposes.
- To control the STB using an external TLT control device, you must use the STB's EXTERNAL RS-232C CONTROL port for communication purposes. See Reference section, "TLT Communication Parameters," for further information.

Application Tuning Mode / Pro:Centric Direct

In Application Tuning Mode, the STB's Channel Map resides in an application, such as LG's Pro:Centric Direct HTML application. With Pro:Centric Direct, the Channel Map is created in the Pro:Centric server's Admin Client web editor, and the tuning operation of the STB is controlled and restricted based on this Pro:Centric Direct Channel Map. The Pro:Centric server may be either a standard server installed on-site or a Pro:Centric Cloud (virtual) server hosted on LG's Pro:Centric Cloud portal.

Note: The Pro:Centric Cloud portal (applicable only with CPU v3.44.60 or later and PTC v1.00.010 or later) supports Pro:Centric Direct application delivery via Unicast Mode only. Contact your LG service representative for additional information.

Application Tuning Mode with the Pro:Centric Direct HTML application provides the following features:

- Decryption of each Pro:Idiom[®] encrypted channel.
- Logical channel tuning of physical RF channels (digital and analog) and IP streams.
- Mapping of RF channels with minor (program) numbers up to 999.
- Start Channel set for RF or IP delivered content.
- Pro:Centric data delivery over RF (on-site Pro:Centric server only) or IP (on-site Pro:Centric server or Pro:Centric Cloud server).
- STB Zoning (Installer Menu items only) and Wi-Fi Zoning options for location-specific configurations.
- External control via either the STB's EXT MPI CONTROL port or EXTERNAL RS-232C CONTROL port.

You must use the Pro:Centric Direct Admin Client / Channel Map configuration utility to create the Pro:Centric Direct Channel Map, define channel attributes, and set the Start Channel. Refer to the ***Pro:Centric Direct Admin Client User Guide*** or the ***Pro:Centric Cloud Admin Client User Guide***, as applicable, for further information.

Note: STB Zoning and Wi-Fi Zoning features are supported via ".tlx" file—typically a Clone (.tlx) file that has been created from a Master STB Setup. See Reference section, "Using the STB's Zoning Features," for further information.

While the STB is in Application Tuning Mode:

- The Installer Menu is still accessible using an LG Installer Remote; however, all Installer Menu items will be read-only.
- While it is possible to update an STB's Installer Menu and/or Setup Menu settings locally using a USB memory device / Clone (.tlx) file, any Pro:Centric Direct configuration changes are typically made remotely via the Pro:Centric server / Pro:Centric Direct Admin Client. The Admin Client's Channel Map configuration utility enables you to create and edit the Pro:Centric Direct Channel Map, while the TV Configuration utility (in conjunction with a Clone [.tlx] file loaded on a server carousel) enables you to make changes to STB Installer Menu and/or Setup Menu settings.
- If it becomes necessary to restore the STB to Pass-through Mode, it is possible to do so. See Reference section, "Restoring Factory Defaults on the STB(s)," for further information.

Refer to the ***Pro:Centric Direct Admin Client User Guide*** or the ***Pro:Centric Cloud Admin Client User Guide***, as applicable, for further information on configuration and management via the Pro:Centric Direct Admin Client.

Commercial Mode Overview (Cont.)

External Control

Installer Menu item 030 EXTCTL/ACKMASK determines the availability of external control in accordance with the mode in which the STB is currently operating. See bullets below as well as Installer Menu item 030 description on page 58 for details. External control is prohibited by default in Application Tuning Mode. Set item 030 to allow external control via (only) one of the applicable ports.

- To control the STB using an external MPI control device, you must use the STB's EXT MPI CONTROL port for communication purposes.
- To control the STB using an external TLT control device, you must use the STB's EXTERNAL RS-232C CONTROL port for communication purposes. See Reference section, "TLT Communication Parameters," for further information.

Determining the STB Operating Mode

To determine the operating mode of the STB, press **MENU** on the Installer Remote. The menu displayed depends on the operating mode. See examples below.

If the Function Menu appears, the STB is in a mode (FTG, ATM, PPV, etc.) that does not allow the end user to change the fundamental STB setup. If the STB setup menus (Quick Settings) appear, the STB is in Pass-through Mode.

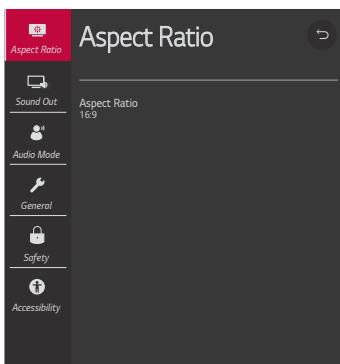

Function Menu
Indicates the STB is not in Pass-through Mode. While the STB is in this mode, Installer Menu settings can be accessed as read-only.

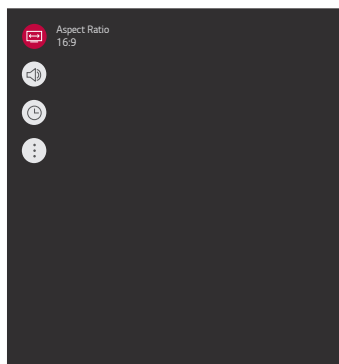

STB Setup Menus
Shows that the STB is in Pass-through Mode.

The STB-6500 supports LG's Pro:Centric Java application, as well as the Pro:Centric Direct HTML application. Only one application may be implemented at a time. The following sections provide an overview of the application features and functionality.

Interactive Menu Features

Both the Pro:Centric Java (GEM) application and the Pro:Centric Direct HTML application enable guests to locate and select television entertainment, check the daily weather, view hotel and surrounding amenities, etc., via custom portal interactive menus. The Pro:Centric Java application provides multiple templates for portal interactive menus, while the Pro:Centric Direct HTML application, in addition to providing multiple templates for portal interactive menus, also enables you to custom-create portal and application content.

Pro:Centric application features include:

- Portal and information screens/pages (including a "Welcome" page) that include branding logos.
- An optional customized user interface (custom "skins").
- Billboards and points-of-interest maps that can be customized to focus on hotel amenities, local attractions and businesses, restaurants, news, events, etc.
- An optional Weather billboard that includes a local radar map, current conditions, and a four day forecast.
- An interactive channel guide that provides a channel list with channel icons. An electronic program guide (EPG) is an optional feature that displays up to three days of programming information viewable by channel and time.
- Video spooling that enables the hotel to deliver a video file to guest TVs for promotion and information purposes.

In addition to the those indicated above, the Pro:Centric Direct HTML application also offers the following features:

- Optional messaging features, including notices, ticker text, and ad banners.
- Additional media support, i.e., music accompaniment, for portal displays.
- An optional flight information display.

For each Pro:Centric application, an Admin Client web editor/content wizard is provided for customer configuration of portal content. The Pro:Centric Direct Admin Client features the Pro:Centric Direct Project Editor, which provides design tools (including templates) that enable customization of all portal pages. Please contact your LG service representative for further information.

Note: Customized content is typically defined by the service integrator and/or hotel administrators. LG does not provide hotel-specific content.

Interactive Menu Navigation

An LG Pro:Centric-capable remote control provides access to both interactive menus and regular STB/display features. Press **PORTAL** on the remote to access the interactive menus.

Note: Interactive menu options may vary, depending on Pro:Centric features enabled for the site and/or customized content. The following examples show typical portal interactive menus.

Pro:Centric Operation (Cont.)

Example: Pro:Centric Java Application Portal



Example: Pro:Centric Direct HTML Application Portal

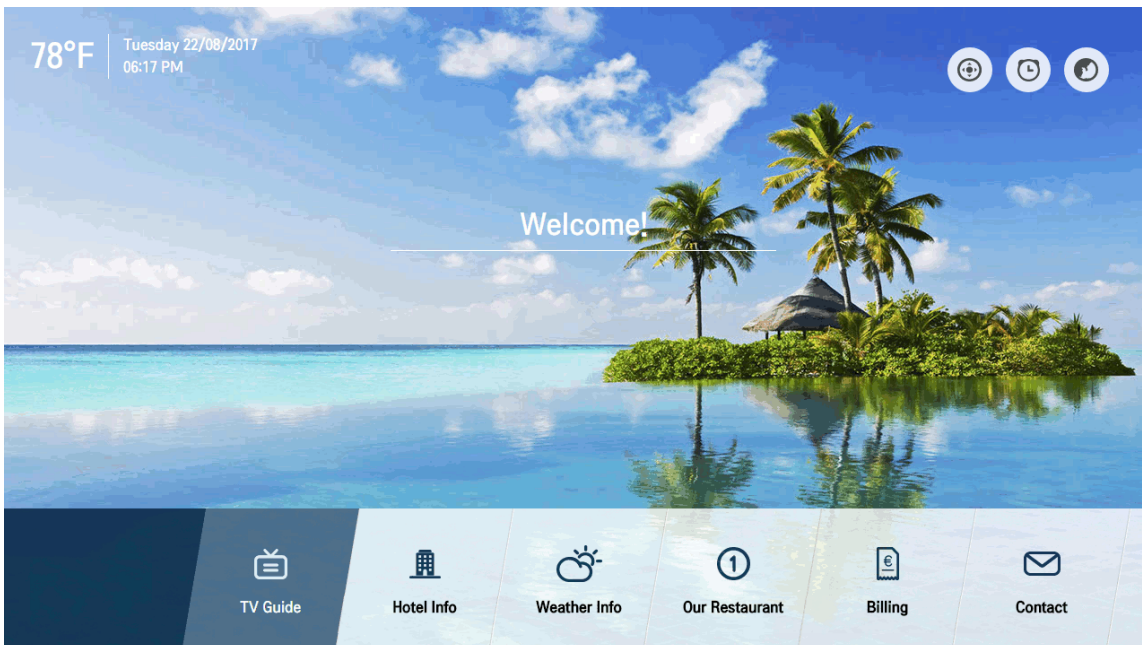

Pro:Centric Java Application Setup

The Pro:Centric Java (GEM) application operates in conjunction with FTG and PPV Modes. This section provides an overview of the setup required for the Pro:Centric features. Administration and management options for the Pro:Centric server are described in detail in the **Pro:Centric Server Admin Client User Guide**. This document describes only those settings that must be specified on the STB to enable Pro:Centric remote management and/or the Pro:Centric Java application.

- Remote management (E-Z Installation): The Pro:Centric Admin Client provides remote management facilities for downloading software updates as well as facilities for downloading a Clone/Configuration (.tlx) file for FTG Mode configuration.
- Pro:Centric Java application: The application comprises the Pro:Centric interactive menus/features described on page 19. Pro:Centric application settings are managed via the Pro:Centric Admin Client for the Java application.

The Pro:Centric remote management facilities and application download are based on Installer Menu item settings that are used to set up the STB's Pro:Centric features. The Installer Menu / Pro:Centric server settings can be configured using one of the methods described below.

STB in Factory Default State

When the STB is in a factory default state, LG's First Use Wizard provides automated or manual options for configuring the STB's Pro:Centric server settings. See "First Use Wizard" on pages 25 to 26 for further information. The First Use / EZ-Manager Wizard (i.e., Solution Settings) also provides a USB configuration option that enables you to configure an STB for FTG Mode using a Clone/Configuration (.tlx) file stored on a USB memory device. The ".tlx" file incorporates FTG Installer Menu settings, including Installer Menu items 098 PRO:CENTRIC and 119 DATA CHANNEL, which are used to set up the STB's Pro:Centric features.

STB in Pass-through Mode

If the First Use Wizard has been exited and the STB is in Pass-through Mode, use one of the following options, in accordance with the Pro:Centric server output:

- RF output: Set Installer Menu items 098 PRO:CENTRIC and 119 DATA CHANNEL to the appropriate values. See Installer Menu information on pages 50 to 63 for further details. Also, as necessary, refer to "Custom Master STB Setup" on pages 64 to 66 and/or cloning information on pages 67 to 73.
- RF or IP output: Configure the appropriate Pro:Centric server settings in the IP Environment / Pro:Centric Menu. See "Accessing the IP Environment Menu" on page 81 and "Pro:Centric Setup" on pages 87 to 90 for further information.

Note: When the STB is in either Pass-through Mode or FTG Mode, you can also leave Installer Menu item 119 DATA CHANNEL set to its default value (255) to enable the STB's Data Channel Auto Search feature to set the DATA CHANNEL value. See item 119 description on page 62 for additional information.

Pro:Centric Operation (Cont.)

STB in FTG Mode

If the STB is already in FTG Mode, use the Cloud Configuration Tool to update Installer Menu items #98 Pro:Centric and #119 Data Channel (along with their affiliated fields). Then, transfer the FTG Installer Menu settings to the STB. Refer to the FTG Mode overview on pages 15 to 16 for further information on FTG Mode operation and configuration. Also, see note above regarding the option to use the STB's Data Channel Auto Search feature to set the DATA CHANNEL value.

Pro:Centric Direct HTML Application Setup

The Pro:Centric Direct HTML application operates only in Application Tuning Mode (ATM). This section provides an overview of the setup required for the Pro:Centric Direct features. Administration and management options for the Pro:Centric server are described in detail in the applicable Admin Client User Guide—either the *Pro:Centric Direct Admin Client User Guide* or the *Pro:Centric Cloud Admin Client User Guide*. This document describes only those settings that must be specified on the TVs to enable Pro:Centric remote management and/or the Pro:Centric Direct HTML application.

- Remote management (E-Z Installation): The Pro:Centric Direct Admin Client provides remote management facilities for downloading software updates as well as facilities for downloading Installer Menu configuration updates via Clone (.tx) file to the STBs at the property.

Note: The Pro:Centric Direct Channel Map is created and maintained in the Pro:Centric Direct Admin Client. Thus, any Clone file that is loaded on the server for remote configuration may only contain Installer Menu and/or Setup Menu profiles.

- Pro:Centric Direct HTML application: The application comprises the Pro:Centric interactive menus/features described on page 19. Pro:Centric Direct application settings are managed via the Pro:Centric Direct Admin Client.

The Pro:Centric remote management facilities and application download are based on Installer Menu item settings that are used to set up the STB's Pro:Centric features. The Installer Menu / Pro:Centric server settings can be configured using one of the methods described below.

STB in Factory Default State

When the STB is in a factory default state, LG's First Use Wizard provides automated or manual options for configuring the STB's Pro:Centric server settings. See "First Use Wizard" on pages 25 to 26 for further information and also notes below. The First Use / EZ-Manager Wizard (i.e., Solution Settings) also provides a USB configuration option that enables you to configure the STB's Installer Menu settings using a Clone (.tx) file stored on a USB memory device. Installer Menu items 098 PRO:CENTRIC and 119 DATA CHANNEL are used to set up the STB's Pro:Centric features.

Note: The automated option referenced above is applicable for an on-site Pro:Centric server only.

Note: If the server is configured on LG's Pro:Centric Cloud portal, you will need the six-digit installation code for this property in order to complete the Pro:Centric Cloud server setup on the STB. The installation code is generated in the Pro:Centric Cloud portal. Refer to the *Pro:Centric Cloud Portal User Guide* for further information.

STB in Pass-through Mode

If the First Use Wizard has been exited and the STB is in Pass-through Mode, use one of the following options, in accordance with the Pro:Centric server output:

- RF output: Set Installer Menu items 098 PRO:CENTRIC and 119 DATA CHANNEL to the appropriate values. See Installer Menu information on pages 50 to 63 for further details. Also, as necessary, refer to “Custom Master STB Setup” on pages 64 to 66 and/or cloning information on pages 67 to 73.
- RF or IP output: Configure the appropriate Pro:Centric server settings in the IP Environment / Pro:Centric Menu. See “Accessing the IP Environment Menu” on page 81 and “Pro:Centric Setup” on pages 87 to 90 for further information.

Note for on-site Pro:Centric server only: When the STB is in either Pass-through Mode or Application Tuning Mode, you can also leave Installer Menu item 119 DATA CHANNEL set to its default value (255) to enable the STB’s Data Channel Auto Search feature to set the DATA CHANNEL value. See item 119 description on page 62 for additional information.

STB in Application Tuning Mode

If the STB is already in Application Tuning Mode, use a Master STB of the same model to create and export a Clone (.tlx) file with the appropriate settings for Installer Menu items 098 PRO:CENTRIC and 119 DATA CHANNEL. Then, transfer (import) the Clone file to the Target STB. Refer to the Application Tuning Mode / Pro:Centric Direct overview on pages 17 to 18 for further information on Pro:Centric Direct operation and configuration. To transfer the Clone file remotely, use the appropriate utilities in the Pro:Centric Direct Admin Client to upload the Clone file to the Pro:Centric server and set up its distribution to the Target STB(s) at the site. See also note above regarding the option, applicable for an on-site server only, to use the STB’s Data Channel Auto Search feature to set the DATA CHANNEL value.

Setting the Video Output Resolution

The first time you turn ON the STB/display panel, a Please Select Video Output Resolution menu will be displayed, and you will need to select the appropriate option—720p, 1080p, 1366 x 768, or 2160p—for the STB's video output format. You cannot proceed with STB configuration until you make a selection.

Refer to documentation for the applicable display panel(s) to determine the appropriate setting. The selected resolution should be compatible with the display panel's native video resolution. For example, 2160p requires a UHD display panel.

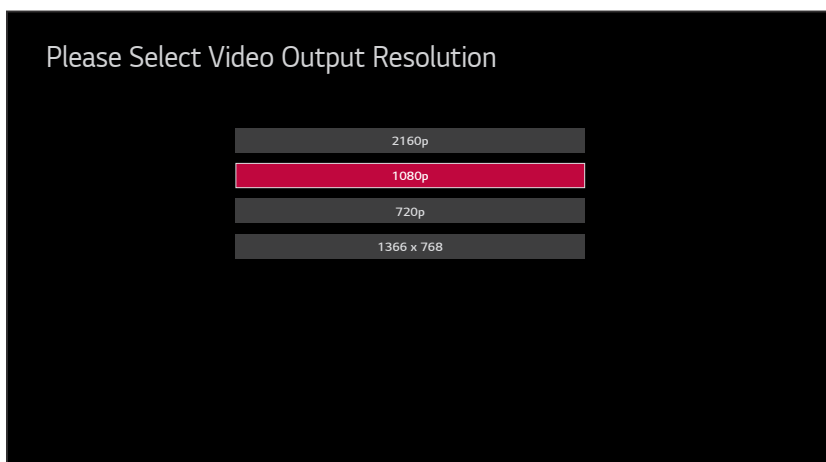

Note: After it is turned ON, the STB begins an initialization process, and it may take several minutes for the Please Select Video Output Resolution menu to be displayed.

1. Use the Up/Down arrows on the Installer Remote to select the appropriate video output resolution option, and then press **OK**.

The STB's default video output resolution is 1080p; however, if 720p is initially selected/highlighted in this screen, the STB has detected this as the highest resolution supported by the connected display panel. If you select the highlighted option, the Please Select Video Output Resolution menu will close and the First Use Wizard Welcome screen will be displayed (see also "First Use Wizard" on pages 25 to 26). Proceed with Commercial Mode setup as required.

Note: If you select one of the other resolution options, a Changing Video Output Resolution screen will be displayed, and the STB will reboot within a few seconds to change the resolution per your selection. Continue with step 2.

2. When the STB reboot is complete (it may take a few minutes), you will be prompted to confirm the new video output resolution. Use the arrow keys on the Installer Remote to select **Yes** in the confirmation screen, and then press **OK** on the Installer Remote.

Note: If there is no user interaction within 10 seconds, or if you select "No" in the confirmation screen, the STB will reboot and revert to the default resolution. After this reboot is complete, the Please Select Video Output Resolution menu will be redisplayed.

Once you select and confirm the video output resolution, the First Use Wizard will be displayed. Proceed with Commercial Mode setup as required.

Note: If required at a later time, you can also change the video output resolution in the STB Installer Menu (item 105 VID OUT FORMAT) or via USB memory device / ".ttx" file. In either case, the STB will need to reboot (see item 105 description on page 60 for additional information).

LG's First Use Wizard, comprising multiple configuration options, is initiated once the video output resolution is set (see previous page) and subsequently each time the STB/display panel is turned ON, until one of its configuration methods has been completed or the wizard is exited. Use the Installer Remote to make selections and complete each step.

- **Basic Settings:** Initiates the Basic Settings Wizard, which enables you to select basic STB settings, including the STB's language and location, and run Channel Tuning. It also allows you to configure the STB's network settings, as well as custom portal settings, if desired. See "Basic Settings Wizard" on pages 27 to 31 for further information.
- **Solution Settings** (default): Initiates the EZ-Manager Wizard. The primary purpose of the EZ-Manager Wizard is to guide you through the process either of configuring essential Installer Menu items for Pro:Centric operation with a standard on-site Pro:Centric server or setting up configuration for Pro:Centric operation via LG's Pro:Centric Cloud.

While the EZ-Manager Wizard is intended primarily for Pro:Centric-related configuration, the wizard also offers Zoning and network configuration options and, in addition, enables you to access the STB Manager / USB download options as part of the configuration process, if desired, to perform USB configuration and/or update functions. See "Solution Settings / EZ-Manager Wizard" on pages 32 to 44 for further information.

- **IP Environment Settings:** Enables you to access the IP Environment Menu to set up network features of the STB, including Pro:Centric and/or Media Share features. See "IP Environment Setup" on pages 81 to 98 for further information.



Caution: Do NOT unplug the STB power cord or remove the antenna cable or, if applicable, the LAN cable during the configuration process, as doing so will interrupt the current step and may corrupt the configuration data.

Before You Begin

- If you plan to create a customized Master STB Setup using the procedure described on pages 64 to 66, be sure to exit the LG First Use Wizard in order to avoid setup conflicts or setting modes that may cause unintended behavior or restrict the custom setup procedure. See also "Initiate Configuration or Exit the First Use Wizard" on the following page.
- If it has been completed or exited and therefore does not display, the First Use Wizard can be reactivated; however, this requires that you restore the STB to a factory default condition. See Reference section, "Restoring Factory Defaults on the STB(s)," for further information.
- If you would like to enable the SoftAP and/or Beacon Media Share features or select pre-loaded / Smart Launcher applications on an STB that will eventually be configured for FTG Mode, you will need to use the IP Environment Menu to do so before the TV is configured for FTG Mode. You can access the IP Environment Menu from the First Use Wizard or from the Installer Menu. See "Initiate Configuration or Exit the First Use Wizard" on the following page for information on accessing the IP Environment Menu from the First Use Wizard, and refer to "IP Environment Setup" on pages 81 to 98 for detailed information on the IP Environment Menu (as well as information on accessing the IP Environment Menu from the Installer Menu). See also "Custom Master STB Setup" on pages 64 to 66, as necessary.

First Use Wizard (Cont.)

Initiate Configuration or Exit the First Use Wizard

The Welcome screen provides a brief introduction to the First Use Wizard.

Note: The Welcome screen is allotted a time frame of 10 seconds, after which the Solution Settings / EZ-Manager Wizard proceeds automatically. If a Pro:Centric server is installed on-site and configured on the system/network and if no location-specific settings are required in the STB, i.e., STB Zone, Wi-Fi Zone, Label, and/or Room Number settings, from this point, the EZ-Manager Wizard can proceed through each of the configuration steps with no further user interaction.

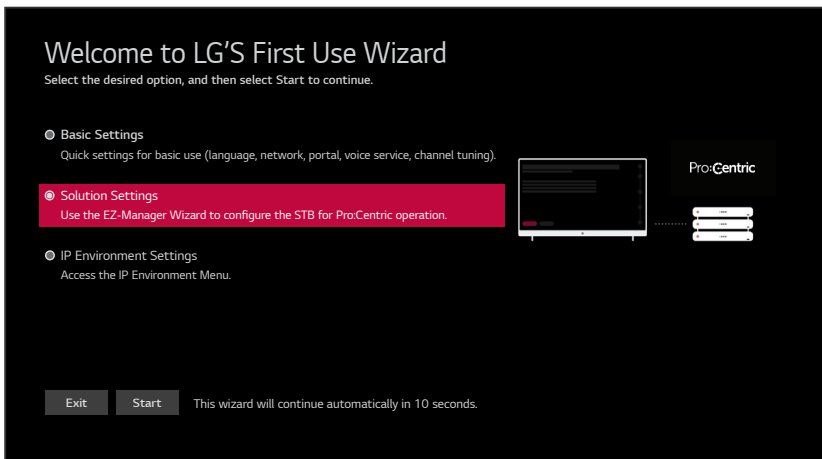

Use the arrow keys on the Installer Remote to select the desired option in the Welcome screen:

- To proceed with the Basic Settings Wizard, select/highlight **Basic Settings**, and then press **OK**. Then, select **Start** and press **OK** to continue. See “Basic Settings Wizard” on pages 27 to 31 for further information.
- To proceed with the EZ-Manager Wizard, select/highlight **Solution Settings**, and then press **OK**. Then, select **Start** and press **OK** to continue. See “Solution Settings / EZ-Manager Wizard” on pages 32 to 44 for further information.
- To access the IP Environment Menu, select/highlight **IP Environment Settings**, and then press **OK**. Then, select **Start** and press **OK** to continue. See “IP Environment Setup” on pages 81 to 98 for further information.
- To exit the First Use Wizard, select/highlight the **Exit** button at the bottom of the screen, and then press **OK**. In the exit confirmation screen, select **Exit**, and then press **OK** once more on the Installer Remote.

Note: If you exit the First Use Wizard from the Welcome screen, no configuration will be performed and all Installer Menu items will retain their default values, including Installer Menu item 119 DATA CHANNEL. The default DATA CHANNEL setting (255) means that the Pro:Centric remote management feature on this STB will be activated if a Pro:Centric server is installed on-site and the Data Channel value is set during a Data Channel Auto Search (see item 119 description on page 62 for additional information). If you actually would like to disable the Pro:Centric feature, both the EZ-Manager Wizard and the IP Environment Menu provide an option to do so, and/or you may disable Pro:Centric by setting the value of Installer Menu item 119 to 0.

This section describes the configuration options available when you select “Basic Settings” from the First Use Wizard / Welcome screen. You can select the “Back” button, where available, to check previous settings, as necessary.

Note: Each Basic Settings Wizard step is allotted a 10-second time frame after which the wizard proceeds automatically. If default settings are appropriate, the wizard can proceed through each configuration step without further user interaction. If you turn OFF the STB/display while the wizard is in progress, when you turn the STB/display back ON, the First Use Wizard / Welcome screen will be displayed. You will then have the opportunity to (re)initiate the desired configuration process.

Note: To exit the wizard at any time, use the arrow keys on the Installer Remote to select/highlight the **X** button at the top right of the screen, and then press **OK**. In the exit confirmation screen, select **Exit**, and then press **OK** once more on the Installer Remote.

1. In the Language & Location screen, use the arrow keys on the Installer Remote to select/highlight each appropriate field in turn—Language or Time Zone—and then press **OK**. Then, use the up/down arrow keys to select the applicable value from the drop-down list of options for the selected field. When you are ready to continue, use the arrow keys on the Installer Remote to select **Next**, and then press **OK**.

Note: The Country field is inaccessible/grayed out because these models are only available in the US. Also, if you allow the wizard to progress without specifying data in this screen, the time zone will be set for “New York” (Eastern Standard Time).

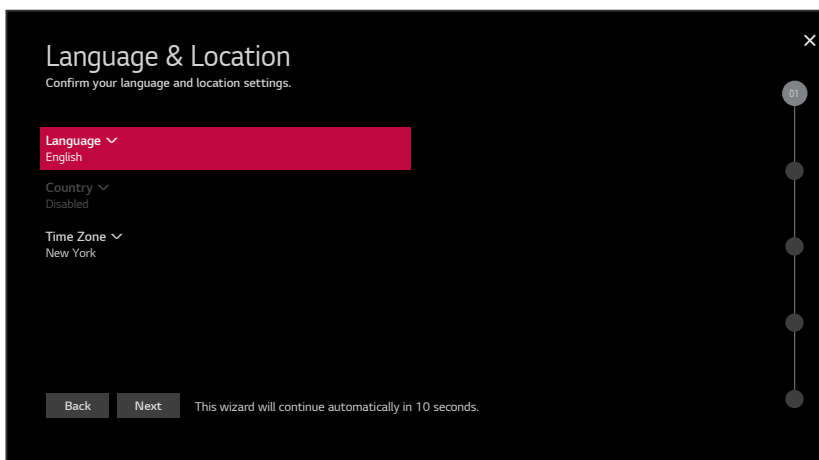

2. The next screen enables you to configure the network settings of the STB. Refer to the appropriate subsection(s) below for information on configuring the wired and/or wireless connection(s) between the STB and the network. When you are ready to continue, use the arrow keys on the Installer Remote to select **Next**, and then press **OK**.

Note: If desired, you can configure both wired and wireless connections to the Local Area Network (LAN). However, note that a wired connection is always prioritized over a wireless connection. That is, if an Ethernet cable is connected between the network and the STB’s LAN port, the STB will default to the wired connection. If the Ethernet cable is removed, the STB will then attempt to establish the wireless connection. Whenever the Ethernet cable is reconnected to the STB’s LAN port, the STB will re-establish the wired connection.

(Continued on next page)

Basic Settings Wizard (Cont.)

(Continued from previous page)

Note: If an Ethernet cable is not currently connected between the STB and the network and you do not want to configure/complete configuration of network settings at this time, you can select/highlight **Skip**, and press **OK** on the Installer Remote to continue to the next step.

Configure a Wired Network Connection

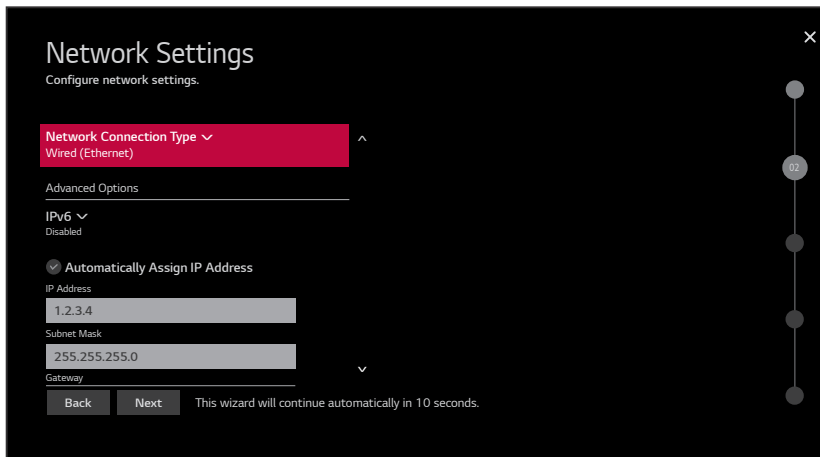

- a. If not already done, connect the appropriate cable between the STB and the network.
- b. Make sure the **Wired (Ethernet)** option is selected in the Network Connection Type field, and then press **OK** on the Installer Remote.
- c. By default, the STB uses DHCP, and if a LAN is detected, the STB will request an IP address from the DHCP server on the network. If the STB is able to connect to the network, the network configuration data will be displayed on the screen as shown in the example above.
If the network is not configured for DHCP, or if you want to enable/disable IPv6 or specify static IP configuration data (applicable only for IPv4), continue with steps (d) and/or (e), respectively
- d. (Optional) To enable IPv6, select/highlight the IPv6 field and press **OK**. Then, select **Enabled** from the drop-down list of options.
- e. (Optional / IPv4 only) If required, you can edit the IP data for this STB as follows:
 - De-select the “Automatically Assign IP Address” checkbox under “Advanced Options.”
 - For each data entry field: Use the arrow keys on the Installer Remote to select the field and press **OK**. You can use the number keys on the Installer Remote to direct enter numeric values or use the arrow keys to select the appropriate characters from the pop-up virtual keyboard displayed at the bottom of the screen. When you are done, select **Enter** from the virtual keyboard, and then press **OK** on the Installer Remote.

Note: You must use the dot “.” key from the virtual keyboard to separate each octet of an IP address.

(Continued on next page)

(Continued from previous page)

Configure a Wireless (Wi-Fi) Network Connection

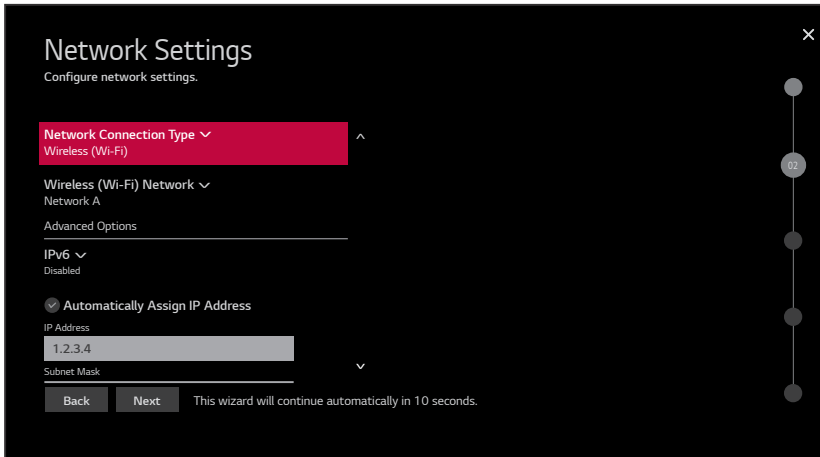

- a. Select/highlight the Network Connection Type field, and press **OK** on the Installer Remote. Then, use the Up/Down arrow keys to select/highlight **Wireless (Wi-Fi)**, and press **OK** once more.
- b. Select/highlight the Wireless (Wi-Fi) Network field, and press **OK** on the Installer Remote. Then, use the Up/Down arrow keys to select/highlight the desired access point from the drop-down list of available options, or select the “Hidden Network” option at the bottom of the list to specify an access point with a hidden SSID. Press **OK** once more.

Note: Make sure you have the network security password—at least eight, but no more than 32 characters—or PIN available if you are attempting to connect to a secured network. If you would like to add an access point with a hidden SSID, you will need to direct enter the SSID—up to 32 characters—of the access point.

- c. Follow the on-screen instructions to complete the appropriate network configuration. Use the Installer Remote to navigate between fields and make entries, etc.

Note: As with a wired connection, you will have the option to specify static IPv4 configuration data for this network connection. Once the initial connection is established, you can de-select the “Automatically Assign IP Address” checkbox under “Advanced Options,” and then modify the IP data, as required. See step (e) of the wired connection procedure above for further information on the data entry fields.

- d. (Optional) To enable IPv6, select/highlight the IPv6 field and press **OK**. Then, select **Enabled** from the drop-down list of options.
- e. Once the wireless network configuration is complete, use the arrow keys on the Installer Remote to select **Connect**, and then press **OK** on the Installer Remote to continue.

Note: The “Connect” button becomes a “Next” button once the connection is successful.

(Continued on next page)

Basic Settings Wizard (Cont.)

(Continued from previous page)

3. In the Portal Settings screen, you can specify the Portal Mode and the Portal Auto Start status for this STB. Use the arrow keys on the Installer Remote to select/highlight each appropriate field in turn—Portal Mode or Portal Auto Start—and then press **OK**. Then, use the up/down arrow keys to select the applicable value from the drop-down list of options for the selected field. When you are ready to continue, use the arrow keys on the Installer Remote to select **Next**, and then press **OK**.

Note: Customizable portal settings are for STBs that will NOT be configured for Pro:Centric operation. If the “Customizable Portal” option is selected in the Portal Mode field, you will be redirected to the IP Environment / Portal Settings Menu when this wizard is complete, so that you can configure the custom portal settings. The Portal Auto Start status is either “On” (display the portal when the STB/display is turned ON) or “Off” (do not display the portal when the STB/display is turned ON).

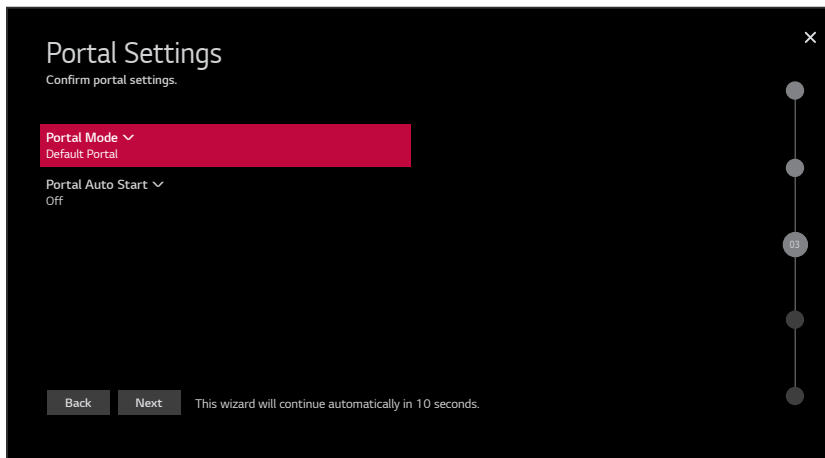

4. In the Voice Service Coverage screen, use the arrow keys on the Installer Remote to select/highlight each appropriate field in turn—LG Service Country or Service Area Zip Code—and then press **OK**. Then, use the up/down arrow keys to select the applicable value from the drop-down list of options for the selected field.

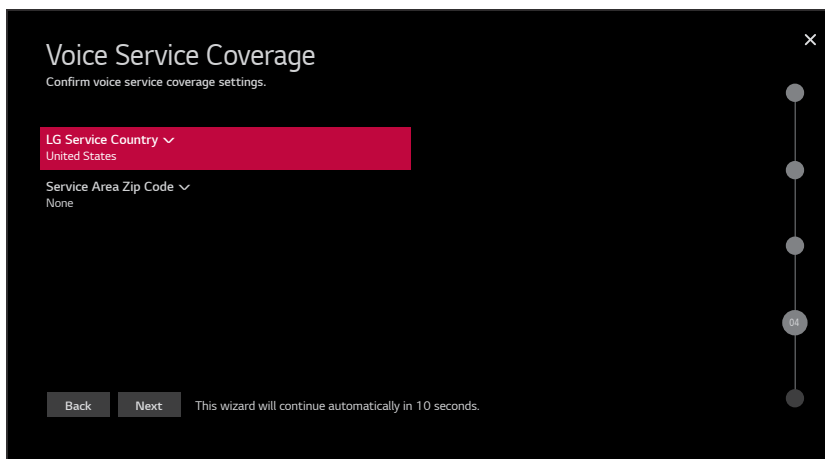

(Continued on next page)

(Continued from previous page)

When you are ready to continue, use the arrow keys on the Installer Remote to select **Next**, and then press **OK**.

5. The Channel Tuning screen is the final step of the Basic Settings Wizard.

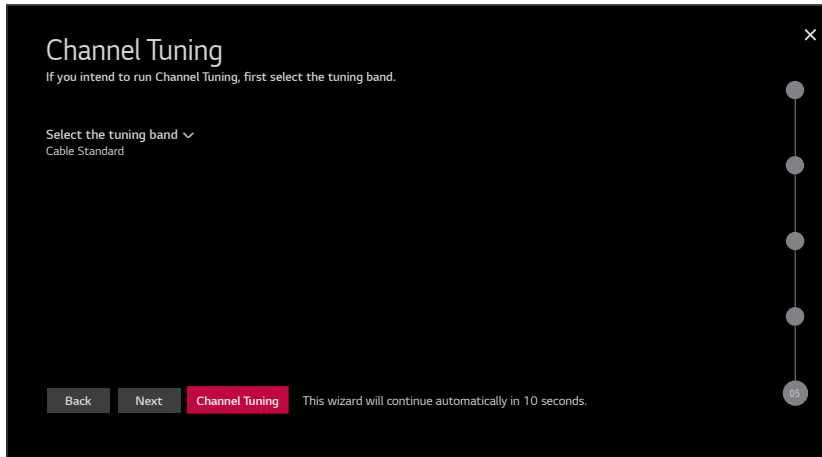

- If you would like to initiate an automated channel scan (i.e., a search for all available digital and analog channels), use the arrow keys on the Installer Remote to select the RF tuning band field, and select the appropriate option. Then, press **OK**. Next, select the **Channel Tuning** button at the bottom of the screen, and press **OK**.

Tuning progress will be shown in a new Channel Tuning screen. The scan typically takes a few minutes. When the channel scan is complete, the TV will launch the IP Environment Menu. See additional information below.

- If you would like to continue with the basic STB setup without running Channel Tuning, select the **Done** button at the bottom of the screen, and press **OK**. The STB will launch the IP Environment Menu. See additional information below.

As indicated above, the IP Environment Menu is always launched after the Basic Settings Wizard is complete (and once Channel Tuning is finished, if applicable). If you selected the “Customized Portal” option in the Portal Settings screen, the IP Environment / Portal Settings Menu will be on display when the IP Environment Menu launches, and you can configure the portal, as desired. If you did not select “Customized Portal,” the IP Environment Menu launches with the Network Menu options on display (default IP Environment Menu launch scenario). See “IP Environment Setup” on pages 81 to 98 for further information on the options available in the IP Environment Menu.

Solution Settings / EZ-Manager Wizard

This section describes the EZ-Manager Wizard that is initiated when you select “Solution Settings” from the First Use Wizard / Welcome screen.

Note: If the Pro:Centric server is installed on-site and configured on the system/network and if no location-specific settings are required in the STB, i.e., STB Zone, Wi-Fi Zone, Label, and/or Room Number settings, you can simply turn ON the STB/display, and once initiated, the wizard will proceed through each of the configuration steps with no further user interaction.

Note: Select the “Back” button, where available, to check previous settings, as necessary. Also note that if you turn OFF the STB/display while the wizard is in progress, when you turn the STB/display back ON, a “Diagnostics” screen will be displayed (see also note below).

Note: If any of the configuration steps fails, you will see a “Diagnostics” screen with an indication of the failure. You will then have the opportunity to reinitiate the configuration process from the previous screen or exit the EZ-Manager Wizard.

STB Configuration Options

From the STB Configuration Options screen, you can choose how to proceed with the configuration of this STB/display.



Note: If you intend to use the Zoning feature(s) on the STB for location-specific configuration purposes, select the “Zones & Room Number” option from this screen and assign the appropriate STB Zone # and/or the Wi-Fi Zone # in the STB BEFORE you continue with additional configuration.

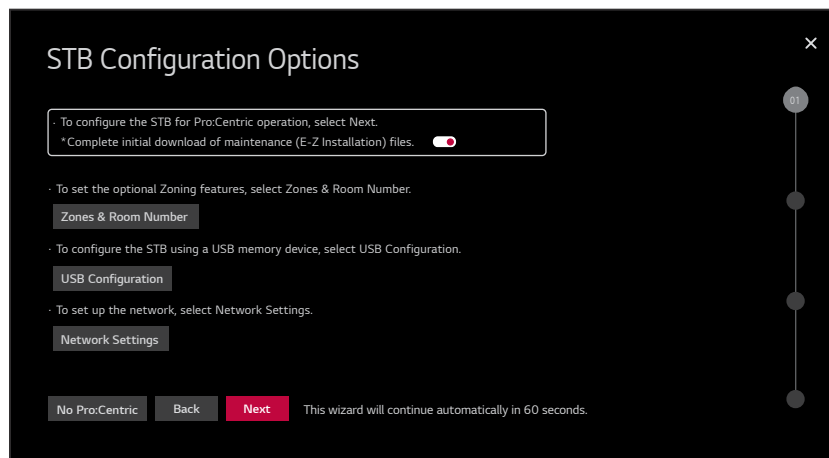

Note: If there is no user action in this screen within one minute, the wizard will automatically continue to the next configuration step. If you would like to exit the wizard at any time, use the arrow keys on the Installer Remote to select/highlight the **X** button at the top right of the screen, and then press **OK**. In the exit confirmation screen, select the appropriate “Exit” option (see also note below), and then press **OK** once more on the Installer Remote.

Note: If you choose to exit the EZ-Manager Wizard from this point on, you will have the option to save any settings made by selecting **Save & Exit** in the exit confirmation screen. Or, you can exit the wizard without saving any settings by simply selecting **Exit** in the confirmation screen.

(Continued on next page)

(Continued from previous page)

Use the Up/Down arrow keys on the Installer Remote to navigate between options on this screen.

- If you do not intend to install/configure a Pro:Centric server on this system and you do not wish to use any of the additional options available from this screen, exit the wizard as follows: Select **No Pro:Centric**, and then press **OK**. This will disable the Pro:Centric feature of this STB (i.e., Installer Menu item 119 DATA CHANNEL will be set to 0) and exit the wizard. In the exit confirmation screen, select **Exit**, and then press **OK** once more on the Installer Remote.
- To continue with Pro:Centric configuration, select **Next** (default) and press **OK** on the Installer Remote. See “Configure Pro:Centric Settings” on pages 37 to 41 for additional information.

Note for on-site Pro:Centric server: By default, any applicable maintenance (E-Z Installation) files are downloaded as part of the STB configuration. If you would like to skip the initial maintenance file download, select the (Yes) toggle button on the screen and press **OK** to change the value to (No). Maintenance files will still be downloaded during the daily update event, per Installer Menu item 121 setting.

- To set the Zoning feature(s) on the STB, select **Zones & Room Number**. See “Zones and Room Number Assignments” below for further information.
- To configure the network settings of the STB, select **Network Settings**. See “Network Settings” on pages 34 to 36 for further information.
- To access the STB Manager / USB download options, select **USB Configuration**. See “USB Configuration” on pages 43 to 44 for further information.

Zones and Room Number Assignments

You may complete one or more of the fields in the Zones, Label, and Room Number screen or leave them at their default settings (STB Zone and Wi-Fi Zone) or blank (Label and Room Number), as desired. However, if you intend to use either of the Zoning features—STB Zoning and/or Wi-Fi Zoning—on this STB, you **MUST** specify the appropriate values in the STB Zone and/or Wi-Fi Zone fields as described below. See Reference section, “Using the STB’s Zoning Features,” for further information.

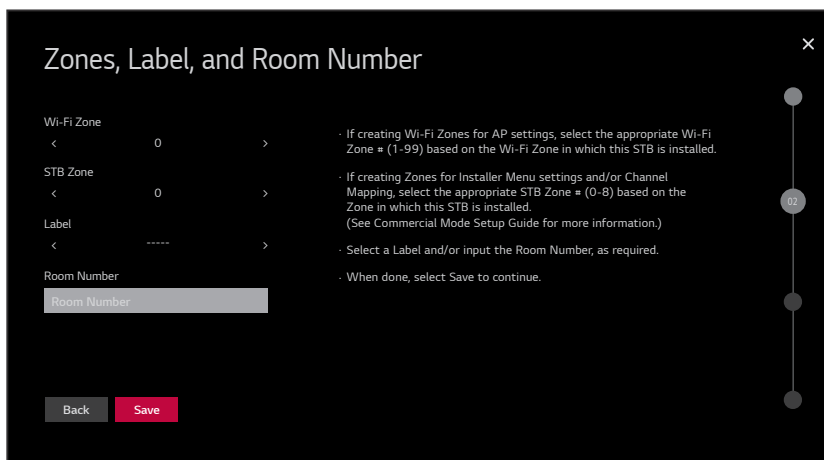

(Continued on next page)

Solution Settings / EZ-Manager Wizard (Cont.)

(Continued from previous page)

Note: Zoning features are only applicable for STBs that will be configured using a “.tlx” file (local or remote configuration).

1. Complete the appropriate field(s) as described below. Use the Left/Right arrow keys on the Installer Remote to navigate between each of the fields.
 - **Wi-Fi Zone:** Enables you to set a Wi-Fi Zone # so that the STB can be configured with a particular access point's login data for wireless networking. Login data (i.e., SSID, security type, and security key) may be provided in a Clone/Configuration (.tlx) file.
To assign a Wi-Fi Zone, navigate to the Wi-Fi Zone field at the top left of the screen, and use the Left/Right arrow keys to specify the desired Wi-Fi Zone # (1–99).
 - **STB Zone:** Enables you to set an STB Zone # so that the STB can be configured with Installer Menu and/or Setup Menu settings intended only for the assigned Zone. The Installer Menu and/or Setup Menu settings may be provided in a Clone/Configuration (.tlx) file. If the STB is being configured for FTG Mode, the STB Zone # setting also allows the STB to omit channels that have been restricted in the FTG Channel Map.
To change the STB Zone from its default value (0), navigate to the STB Zone field, and use the Left/Right arrow keys to specify the desired STB Zone # (1–8).
 - **Label:** Allows you to select a North, South, East, or West text label for this STB. In the Label field, use the Left/Right arrow keys to select the applicable label.
 - **Room Number:** Allows you to specify the number of the room—up to 16 characters—in which the STB is located. To enter a room number, navigate to the Room Number field and press **OK**. You can then use the number keys on the Installer Remote to direct enter a room number, or you can use the arrow keys to select the appropriate alphanumeric character(s) from the pop-up virtual keyboard at the bottom of the screen. When you are done, select **Enter** from the virtual keyboard, and then press **OK** on the Installer Remote.
Note: The STB name (default: “[LG] webOS STB”) will be changed to the room number specified here. See “Media Share Setup” on pages 95 to 98 for further information on the STB name.
2. When you are ready to continue, use the arrow keys to select **Save**, and then press **OK** on the Installer Remote to return to the STB Configuration Options screen. Then, proceed as required from the STB Configuration Options screen.

Network Settings

You may configure wired and/or wireless network settings for the STB.

Note: If desired, you can configure both wired and wireless connections to the Local Area Network (LAN). However, note that a wired connection is always prioritized over a wireless connection. That is, if an Ethernet cable is connected between the network and the STB's LAN port, the STB will default to the wired connection. If the Ethernet cable is removed, the STB will then attempt to establish the wireless connection. Whenever the Ethernet cable is reconnected to the STB's LAN port, the STB will re-establish the wired connection.

(Continued on next page)

(Continued from previous page)

1. Refer to the appropriate subsection(s) below for information on configuring the wired and/or wireless connection(s) between the STB and the network.

Configure a Wired Network Connection

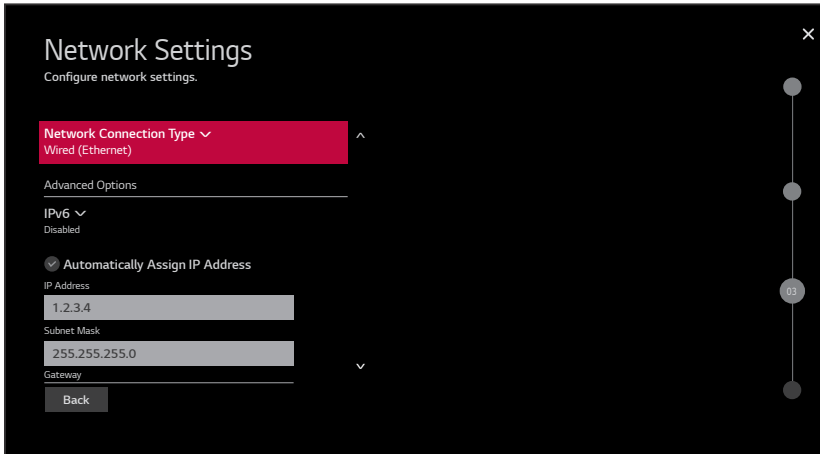

- a. If not already done, connect the appropriate cable between the STB and the network.
- b. Make sure the **Wired (Ethernet)** option is selected in the Network Connection Type field, and then press **OK** on the Installer Remote.
- c. By default, the STB uses DHCP, and if a LAN is detected, the STB will request an IP address from the DHCP server on the network. If the STB is able to connect to the network, the network configuration data will be displayed on the screen as shown in the example above.

If the network is not configured for DHCP, or if you want to enable/disable IPv6 or specify static IP configuration data (applicable only for IPv4), continue with steps (d) and/or (e), respectively.

- d. (Optional) To enable IPv6, select/highlight the IPv6 field and press **OK**. Then, select **Enabled** from the drop-down list of options.
- e. (Optional / IPv4 only) If required, you can edit the IP data for this STB as follows:
 - De-select the “Automatically Assign IP Address” checkbox under “Advanced Options.”
 - For each data entry field: Use the arrow keys on the Installer Remote to select the field and press **OK**. You can use the number keys on the Installer Remote to direct enter numeric values or use the arrow keys to select the appropriate characters from the pop-up virtual keyboard displayed at the bottom of the screen. When you are done, select **Enter** from the virtual keyboard, and then press **OK** on the Installer Remote.

Note: You must use the dot “.” key from the virtual keyboard to separate each octet of an IP address.

(Continued on next page)

Solution Settings / EZ-Manager Wizard (Cont.)

(Continued from previous page)

Configure a Wireless (Wi-Fi) Network Connection

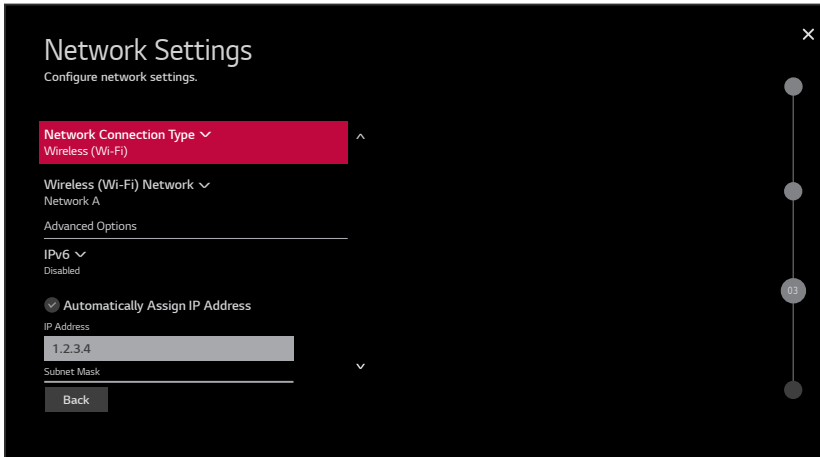

- a. Select/highlight the Network Connection Type field, and press **OK** on the Installer Remote. Then, use the Up/Down arrow keys to select/highlight **Wireless (Wi-Fi)**, and press **OK** once more.
 - b. Select/highlight the Wireless (Wi-Fi) Network field, and press **OK** on the Installer Remote. Then, use the Up/Down arrow keys to select/highlight the desired access point from the drop-down list of available options, or select the “Hidden Network” option at the bottom of the list to specify an access point with a hidden SSID. Press **OK** once more.
Note: Make sure you have the network security password—at least eight, but no more than 32 characters—or PIN available if you are attempting to connect to a secured network. If you would like to add an access point with a hidden SSID, you will need to direct enter the SSID—up to 32 characters—of the access point.
 - c. Follow the on-screen instructions to complete the appropriate network configuration. Use the Installer Remote to navigate between fields and make entries, etc.
Note: As with a wired connection, you will have the option to specify static IPv4 configuration data for this network connection. Once the initial connection is established, you can de-select the “Automatically Assign IP Address” checkbox under “Advanced Options,” and then modify the IP data, as required. See step (e) of the wired connection procedure above for further information on the data entry fields.
 - d. (Optional) To enable IPv6, select/highlight the IPv6 field and press **OK**. Then, select **Enabled** from the drop-down list of options.
 - e. Once the wireless network configuration is complete, Use the arrow keys on the Installer Remote to select **Connect**, and then press **OK** on the Installer Remote.
Note: The “Connect” button disappears once the connection is successful.
2. When you are ready to continue, use the arrow keys to select **Back**, and then press **OK** on the Installer Remote to return to the STB Configuration Options screen. Then, proceed as required from the STB Configuration Options screen.

Pro:Centric Settings

Once you select “Next” from the STB Configuration Options screen, the Configure Pro:Centric Server screen is displayed. Use the Up/Down arrow keys on the Installer Remote to select the appropriate option.

- If there is a Pro:Centric server installed on-site, select/highlight **Standard Pro:Centric Server Settings** and press **OK**. Then, select **Next**, and press **OK** once more. See “Standard Pro:Centric Server Configuration” on pages 37 to 41 to complete the Pro:Centric configuration.
- If you will be using LG’s Pro:Centric Cloud solution to configure the STBs at the site for Pro:Centric operation, select/highlight **LG Pro:Centric Cloud Settings** and press **OK**. Then, select **Next**, and press **OK** once more. See “Pro:Centric Cloud Server Configuration” on page 42 to complete the Pro:Centric configuration.

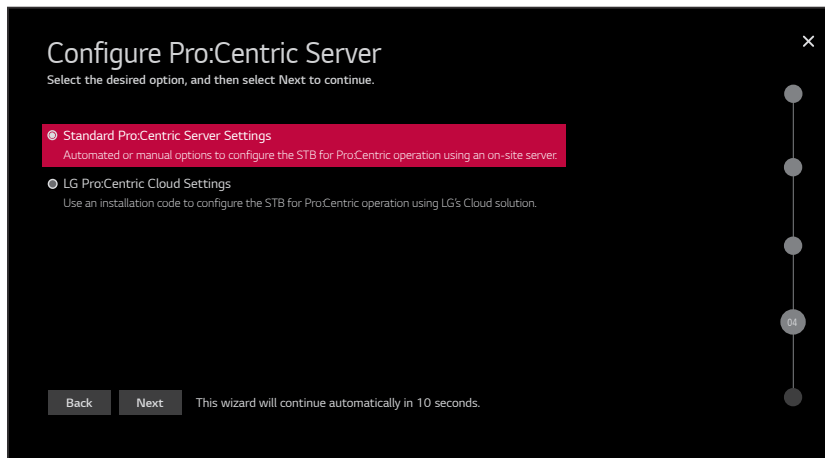

Standard Pro:Centric Server Configuration

This section describes options for completing Pro:Centric configuration when a server is installed on-site.

Note: See “Pro:Centric Cloud Server Configuration” on page 42 for information on Pro:Centric configuration with LG’s Pro:Centric Cloud solution.

Once you select the “Standard Pro:Centric Server Settings” option in the Configure Pro:Centric Server screen, the Searching for Pro:Centric Server screen is displayed (see example on following page).

- You can allow the EZ-Manager Wizard to proceed with a series of automated steps to configure the STB for Pro:Centric operation and then to look for the Pro:Centric application and maintenance (E-Z Installation) files to download. In this case, the wizard uses a search algorithm to determine the Data Channel and the Pro:Centric Application Mode to set in the STB.

Continue with the “Automated Pro:Centric Configuration” subsection below.

- If you already know the settings (e.g., Data Channel and Pro:Centric Application Mode) that need to be configured in order for the STB to connect to the Pro:Centric server and/or if the Pro:Centric server is not yet installed, you may expedite the setup process by entering this data manually.

Continue with the “Manual Pro:Centric Configuration” subsection on page 39.

Solution Settings / EZ-Manager Wizard (Cont.)

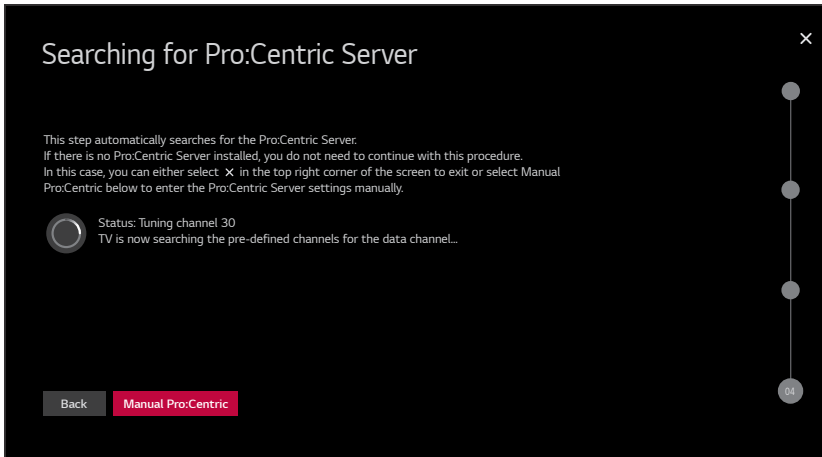

Automated Pro:Centric Configuration

Note: If the server is not yet configured on the system or if Pro:Centric data delivery will be over IP and there is no Domain Name System (DNS) server, use the manual configuration option to configure the STB's Pro:Centric server settings (see "Manual Pro:Centric Configuration" on page 39). See also note below regarding DNS requirements.

Note: If there is a DNS server at the site, you can create a "procentric.local" DNS entry with the Pro:Centric server's IP address. Also, the Pro:Centric server's port number must be set to "80" to allow the automated Pro:Centric IP configuration via the EZ-Manager to find the server.

Once the Pro:Centric data channel is found (a Pro:Centric Server Was Found screen will be displayed) and the Pro:Centric Application Mode is determined, the wizard will advance to a Processing the Pro:Centric Configuration screen, which shows the progress of the data downloads. Note that some steps may require a few minutes.

If the process is successful, no further user interaction is required, though, in some instances, where the option (for example "Next") is available, you may manually move forward to subsequent steps within the wizard to speed up the process.

Note: If, after completing the search, the STB is unable to find the Pro:Centric data channel (while the Searching for Pro:Centric Server screen is on display), the wizard will stop and show a Diagnostics screen that enables you to manually return to the previous screen (to reinitiate the configuration) or exit the wizard.

When the Pro:Centric Configuration is complete, an EZ-Manager Configuration Complete screen is displayed (see example below), and after 10 seconds, the wizard exits, and the STB turns OFF.

Note: With the EZ-Manager Configuration Complete screen on display, you can also manually turn off or reboot the STB. If desired, select **Turn Off** or **Reboot**, respectively, and then press **OK** on the Installer Remote.

(Continued on next page)

(Continued from previous page)

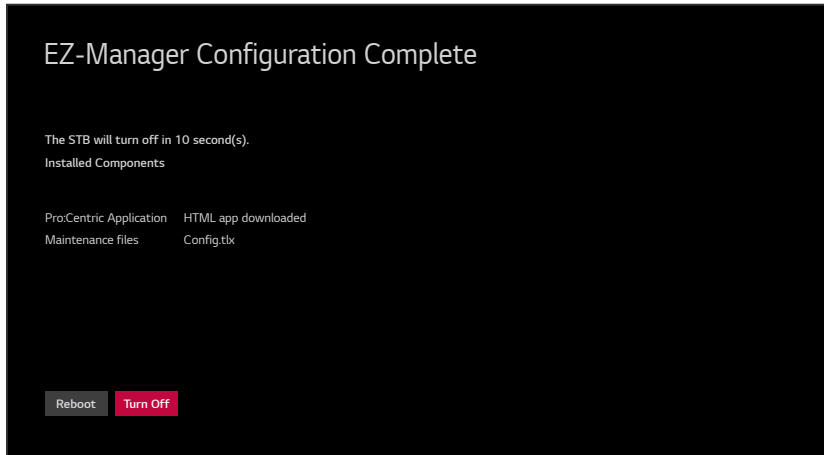

Manual Pro:Centric Configuration

1. With the Searching for Pro:Centric Server screen on display, use the Left/Right arrow keys on the Installer Remote to select **Manual Pro:Centric** at the bottom of the screen, and then press **OK**.

In the Pro:Centric Manual Configuration screen (see examples below), you will be able to configure the appropriate Pro:Centric settings in the STB. Use the Up/Down arrow keys on the Installer Remote to navigate between fields.

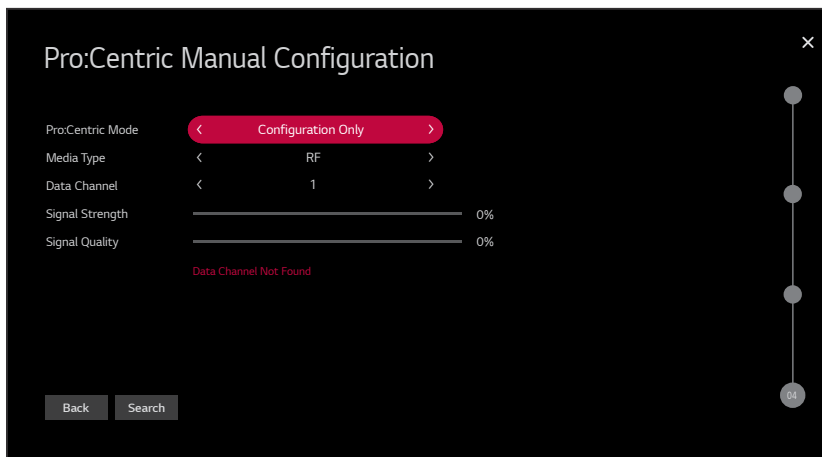

Pro:Centric Manual Configuration Screen with RF Media Fields

Note: By default, the Pro:Centric Manual Configuration screen initially shows RF configuration fields.

(Continued on next page)

Solution Settings / EZ-Manager Wizard (Cont.)

(Continued from previous page)

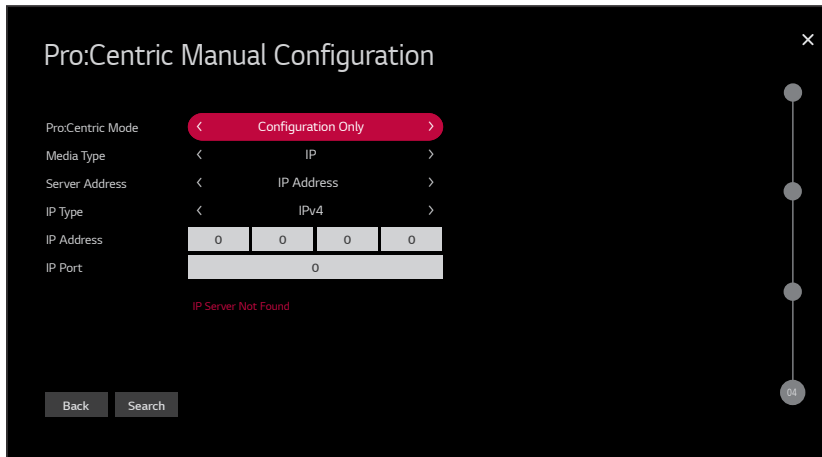

Pro:Centric Manual Configuration Screen with IP Media Fields

2. In the Pro:Centric Mode field, use the Left/Right arrow keys to select the appropriate Pro:Centric Application Mode—**GEM** (Java), **HTML**, or **Configuration Only**.

Note: For remote management only, select **Configuration Only**. The STB will search for STB E-Z Installation data downloads; however, Pro:Centric application data will not be downloaded, i.e., Installer Menu item 098 PRO:CENTRIC will be set to 0.

3. Refer to the appropriate subsection below, depending on the Pro:Centric server configuration, to complete the remaining fields.

RF Configuration

- a) In the Media Type field, use the Left/Right arrow keys to select **RF**.
- b) In the Data Channel field, use the Left/Right arrow keys to select the RF channel number that will be used by the Pro:Centric server as its data channel. The Data Channel value can be set from 1 to 135.*

IP Configuration

- a) In the Media Type field, use the Left/Right arrow keys to select **IP**.
Note: When you select “IP” as the Media Type, the default RF Data Channel and Signal Strength/Quality fields are replaced with Server Address, IP Type, IP Address, and IP Port fields.
- b) The Server Address field provides the option to specify the domain name of the Pro:Centric server instead of the server’s IP address. Use the Left/Right arrow keys to select the desired option—IP Address or Domain Name—for defining the server.

(Continued on next page)

* PCS150R and later Pro:Centric servers do not support HRC or IRC cable channel frequencies.

Solution Settings / EZ-Manager Wizard (Cont.)

(Continued from previous page)

- c) Depending on your selection in the previous step, either:
- Select the appropriate IP type (either IPv4 or IPv6) in the IP Type field, and then enter the Pro:Centric server IP address in the IP Address field. The IP address must match the IPv4 or IPv6 (as applicable) address that is set in the Pro:Centric server.
 - Enter the Pro:Centric server domain name—up to 63 characters (no spaces allowed)—in the Domain Name field. Note that in order for the domain name to be resolved to an IP address, there must be a DNS entry for the domain name.

For each data entry field: Use the arrow keys to select the field and press **OK**. Then, you can either use the number keys on the Installer Remote to directly enter data values, or you can use the arrow keys to select the appropriate number(s)/alphanumeric character(s) from the pop-up virtual keyboard displayed at the bottom of the screen. When you are done, select **Enter** from the virtual keyboard, and then press **OK** on the Installer Remote.

Note: For an IPv6 IP address, you must use the colon “:” key from the virtual keyboard to separate each group.

- d) Enter the Pro:Centric server port number in the IP Port field. The port number must match the port number that is set in the Pro:Centric server.

4. Once all fields are completed as required, you have two options:

- To save the data entered and exit the wizard, use the arrow keys to select the **✖** button at the top right of the screen, and then press **OK**. In the subsequent pop-up confirmation window, select **Save & Exit**, and then press **OK** once more. The Pro:Centric application and/or E-Z Installation data will be downloaded to the STB at a later time. This option is useful, in particular, if the Pro:Centric server has not yet been configured.
- To initiate a real-time download of Pro:Centric application and/or E-Z Installation data, use the arrow keys to select **Search** and press **OK** to verify the configuration data provided in step 3. When the data is verified, the “Search” button becomes a “Next” button. Select **Next** and press **OK** to continue (see also note below).

Note: With RF configuration, Pro:Centric server data must be present on the RF channel selected as the TV’s Data Channel in order for you to select “Next” (you will see a “Data Channel Found” message below the Signal Quality indicator). With IP configuration, Pro:Centric server data must be present via the wired LAN cable connection in order for you to select “Next” (you will see a “IP Server Found” message below the IP Port field).

If you opt to initiate a real-time download in the last step, the EZ-Manager Wizard will proceed with the Pro:Centric application and/or E-Z Installation data downloads (you will see a Processing the Pro:Centric Configuration screen). When the Pro:Centric configuration is complete, an EZ-Manager Configuration Complete screen (see example on page 39) is displayed, and after 10 seconds, the wizard exits, and the STB turns OFF.

Note: With the EZ-Manager Configuration Complete screen on display, you can also manually turn off or reboot the STB. If desired, select **Turn Off** or **Reboot**, respectively, and then press **OK** on the Installer Remote.

Solution Settings / EZ-Manager Wizard (Cont.)

Pro:Centric Cloud Server Configuration

This section describes how to complete the STB's Pro:Centric configuration when the (virtual) server is configured on LG's Pro:Centric Cloud portal (applicable only with CPU v3.44.60 or later and PTC v1.00.010 or later). You will need the six-digit installation code for this property in order to set up the Pro:Centric Cloud server configuration.

Note: The installation code is generated in the Pro:Centric Cloud portal. A user with an Administrator role for this property must provide/generate the code. The procedure below also assumes this property has already been added to the Pro:Centric Cloud portal. Refer to the **Pro:Centric Cloud Portal User Guide** for further information.

Note: See "Standard Pro:Centric Server Configuration" on pages 37 to 41 for information on Pro:Centric configuration when a server is installed on-site.

Once you select the "LG Pro:Centric Cloud Settings" option in the Configure Pro:Centric Server screen, the Pro:Centric Cloud Configuration screen is displayed (see example below). Complete the steps below to connect the STB to the Pro:Centric Cloud server.

1. Enter the six-digit installation code in the Installation Code field.

Use the arrow keys to select the field, and press **OK**. Then, either use the number keys on the Installer Remote to directly enter the installation code, or use the arrow keys to select the appropriate numbers from the pop-up virtual keyboard displayed at the bottom of the screen. When you are done, select **Enter** from the virtual keyboard, and then press **OK** on the Installer Remote.

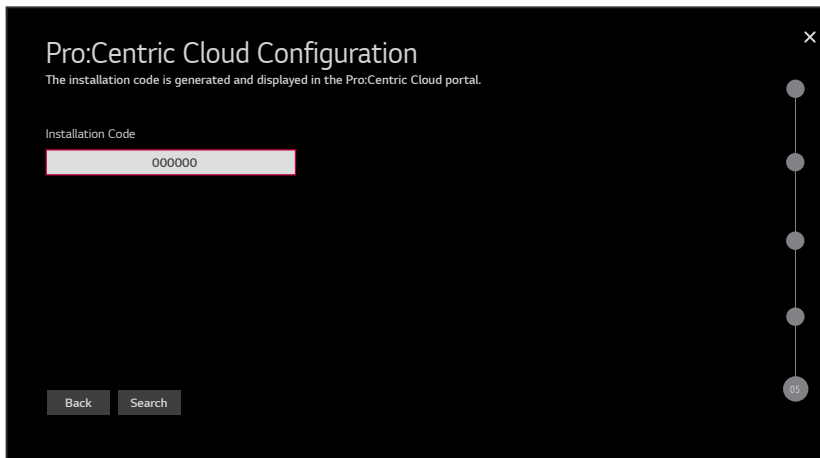

2. Use the arrow keys to select **Search** and press **OK** to verify the installation code. When the installation code is verified, the "Search" button becomes a "Next" button (you also will see a "Server Found" message below the Installation Code field). Select **Next** and press **OK** to continue.

Once the installation code is verified and you continue, the EZ-Manager Wizard will proceed with the Pro:Centric application download (you will see a Processing the Pro:Centric Configuration screen). When the Pro:Centric configuration is complete, an EZ-Manager Configuration Complete screen is displayed (see example on page 39, though note that a list of installed components will not be displayed), and after 10 seconds, the wizard exits, and the STB turns OFF.

Note: With the EZ-Manager Configuration Complete screen on display, you can also manually turn off or reboot the STB. If desired, select **Turn Off** or **Reboot**, respectively, and then press **OK** on the Installer Remote.

USB Configuration

STB Manager / USB download options enable you to download configuration, image, video, or software files from a USB memory device to the STB. You can also use the Ez Download utility available from the menu to select multiple types of files to be downloaded at one time using one process.

Each of the USB download functions requires that you have the appropriate file(s) loaded on a USB memory device. If you wish to perform a software update or download image/icon/video files, the applicable file(s) must be stored in a folder named “LG_DTV” in the root directory of the USB memory device. Clone/Configuration (.tlx) files should simply be stored in the root directory of the USB device.

Note: If appropriate, you may download a Pro:Idiom Media Key (.pim) file via the Ez Download utility. The “.pim” file must be stored in a folder named “LG_DTV” in the root directory of the USB memory device. See Reference section, “Downloading a Pro:Idiom Media Key using a USB Memory Device,” for further information on file requirements.

The procedure below assumes the desired file(s) is/are already loaded onto the USB device. For further information on the STB Manager / USB download options and file requirements, and/or information on creating Clone/Configuration (.tlx) files, refer to the appropriate section(s) in this document.

Before You Begin

- If you intend to use the Zoning feature(s) on this STB, make sure to set the appropriate STB Zone # and/or Wi-Fi Zone # in the EZ-Manager’s Zones, Label, and Room Number screen BEFORE continuing with USB Configuration. See “STB Configuration Options” on page 18 for further information.
- Ensure the USB device to be used has been formatted with FAT format.
- When creating files to be downloaded, avoid using special characters (?, &, @, etc.) in filenames.
- Refer to “Ez Download Utility” on pages 45 to 49 for further information on the Ez Download utility.
- Refer to “Custom Master STB Setup” on pages 64 to 66 for information on creating a Clone (.tlx) file, and/or refer to “Creating an FTG Configuration File” on pages 74 to 77 for information on creating a FTG Configuration (.tlx) file for FTG Mode configuration.
- See Reference section, “Downloading Images or Icons using a USB Memory Device,” for image and icon guidelines.
- See Reference section, “Downloading a Hotel Video using a USB Memory Device,” for video guidelines.
- See Reference section, “Updating STB/PTC Software using a USB Memory Device,” for further information on software updates.

USB Configuration via EZ-Manager Wizard

With either the STB Configuration Options or the Zones, Label, and Room Number screen on display, proceed as follows to configure the STB/display using the USB memory device.

1. Insert the USB memory device with the appropriate file(s) into either of the STB’s USB ports.

(Continued on next page)

Solution Settings / EZ-Manager Wizard (Cont.)

(Continued from previous page)

2. Use the arrow keys on the Installer Remote to select **USB Configuration**, and then press **OK**.

You will be redirected to the STB Manager / USB download options.

Note: You can select the **✕** button at the top right corner of the screen and press **OK** on the Installer Remote at any time to return to the EZ-Manager Wizard.

Note: Ez Download is always selected by default when you initially access the STB Manager. Also note that Diagnostics is for service use only.

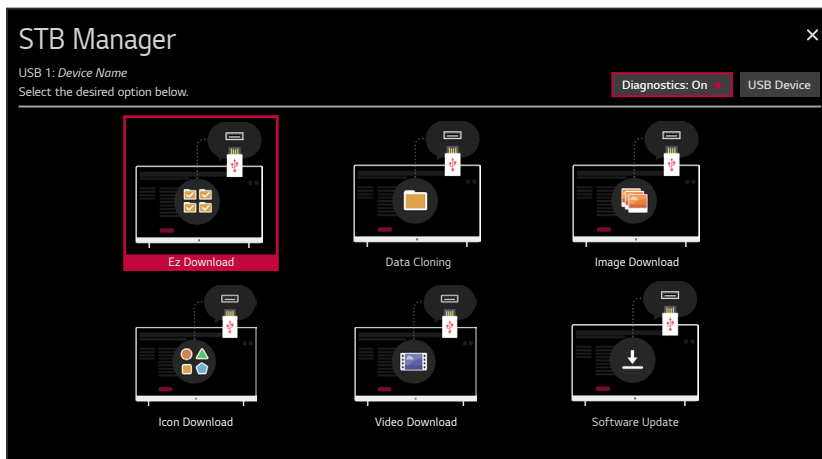

3. If more than one USB memory device is currently connected to the STB, be sure to select the USB device that contains the file(s) you wish to use. If necessary, use the arrow keys on the Installer Remote to select/highlight the **USB Device** button at the top right of the screen and press **OK**. Then, use the Up/Down arrow keys to select the appropriate USB device from the pop-up list of USB devices.
4. Select the appropriate option from the STB Manager, and initiate the desired download(s)/update(s).

Download/update progress will be displayed on the screen. Do NOT remove the USB device while downloads/updates are in progress. When the process is complete, the STB will reboot. Upon restart, depending on the type of download(s)/update(s) completed, either the EZ-Manager STB Configuration Options screen will be redisplayed (image, video, and/or software downloads/updates only) or the STB will tune according to the Start Channel setting in the Installer Menu (STB configured with Clone/Configuration file).

Note: If the STB Configuration Options screen is redisplayed (image, video, and/or software downloads/updates only), you can either proceed with configuration via the EZ-Manager Wizard or exit the EZ-Manager Wizard, as required.

Note: If you updated the STB configuration with a Clone/Configuration file that included a change to Installer Menu item 105 VID OUT FORMAT, when the reboot is complete, you will be prompted to confirm the new video output resolution. See item 105 description on page 60 for further information.

5. Remove the USB memory device, and verify that the appropriate configuration/download(s)/update(s) is/are resident on the STB.

The Ez Download utility, available from the STB Manager, enables you to select multiple files at one time from the files loaded on a USB memory device. You may use this utility to download any one or all of the following to an STB:

- One Clone or FTG Configuration (.tlx) file
- One STB CPU software update
- One PTC software update
- One Pro:Idiom Media Key (.pim) file
- Up to 12 (or 10 MB) application background images
- Up to 12 (or 10 MB) images for each hotel directory in a customized portal
- One hotel icon for a customized portal
- One icon for each website shortcut in a customized portal
- One hotel video for a customized portal

Before You Begin

- Ensure the USB device has been formatted with FAT format.
- Software update, image/icon, video, and Pro:Idiom Media Key files must be stored in a folder named "LG_DTV" in the root directory of the USB memory device. Clone/Configuration (.tlx) files should simply be stored in the root directory of the USB device.
- If you have initiated the Solution Settings / EZ-Manager Wizard, you can use the wizard's "USB Configuration" option to access the Ez Download utility, if desired (see "STB Configuration Options" and/or "USB Configuration" on pages 32 and 43, respectively, as necessary).
- If the STB is currently in Pass-through Mode and you intend to use the Zoning feature(s) on this STB for location-specific configuration purposes, make sure to set the appropriate STB Zone # and/or Wi-Fi Zone # in the STB when directed to do so in the procedure below.
- When creating files to be downloaded, avoid using special characters (?, &, @, etc.) in filenames.
- Refer to "Custom Master STB Setup" on pages 64 to 66 for information on creating a Clone (.tlx) file, and/or refer to "Creating an FTG Configuration File" on pages 74 to 77 for information on creating an FTG Configuration (.tlx) file for FTG Mode configuration.
- See Reference section, "Downloading Images or Icons using a USB Memory Device," for image and icon guidelines.
- See Reference section, "Downloading a Hotel Video using a USB Memory Device," for video guidelines.
- See Reference section, "Updating TV/PTC Software using a USB Memory Device," for further information on software updates.
- See Reference section, "Downloading a Pro:Idiom Media Key using a USB Memory Device," for further information on file requirements.



Caution: Do not unplug the STB power cord or remove the USB memory device during a data download, as doing so may cause the STB to malfunction or harm the USB device, respectively.

Ez Download Utility (Cont.)

Accessing and Using the Ez Download Utility

1. If it is not ON already, turn ON the STB/display panel.
2. The next step depends on whether the First Use Wizard appears on the screen when you turn ON the STB/display:
 - If the wizard is displayed, you can access the Ez Download utility via the Solution Settings / EZ-Manager Wizard, as indicated above (see “Before You Begin”). However, to continue with this procedure and access the Ez Download utility from the STB menus, exit the First Use Wizard. Then, continue with step 3.
 - If the wizard is not displayed, go directly to step 3.
3. If the STB is currently in Pass-through Mode, you would like to transfer (import) a “.tlx” file to the STB via the Ez Download utility, and you intend to use one or both of the STB’s Zoning feature(s), set the appropriate STB Zone # and/or Wi-Fi Zone # in the STB at this time. See Reference section, “Using the STB’s Zoning Features,” for further information.



Note: In order for the proper STB Zone and/or Wi-Fi Zone profile data to be applied, the appropriate STB Zone # and/or Wi-Fi Zone # must be set in the Target STB(s) BEFORE you continue with the Ez Download utility.

4. Insert the USB memory device with the appropriate file(s) into either of the STB’s USB ports.
5. To access the STB Manager from the STB menus:
 - Press **MENU** on the Installer Remote to display the STB setup menus (STB is in Pass-through Mode) or the Function Menu (STB is not in Pass-through Mode).
 - If the Quick Settings Menu is displayed at the left of the screen (i.e., the STB is in Pass-through Mode), select the **All Settings**  menu icon and press **OK** to access the advanced STB setup menus.
 - Use the arrow navigation keys to select/highlight either the **General** menu icon from the STB setup menus or the **Safety** menu icon from the Function Menu. Then, press the number “7” key a total of seven times.
 - If a password prompt is displayed (i.e., STB Manager Password Protection is enabled in the IP Environment / General Menu), key in the STB Manager password and press **OK**.

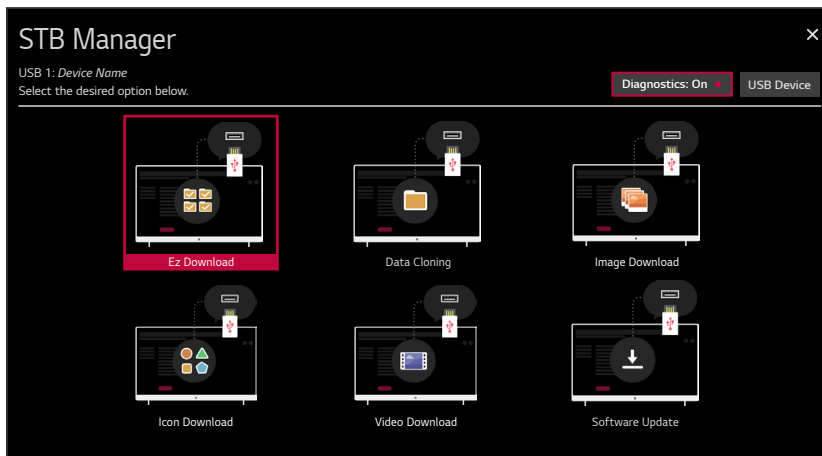

(Continued on next page)

(Continued from previous page)

Note: Ez Download is always selected by default when you initially access the STB Manager. Also note that Diagnostics is for service use only.

6. If more than one USB memory device is currently connected to the STB, be sure to select the USB device that contains the file(s) you wish to use. If necessary, use the arrow keys on the Installer Remote to select/highlight the **USB Device** button at the top right of the screen and press **OK**. Then, use the Up/Down arrow keys to select the appropriate USB device from the pop-up list of USB devices.

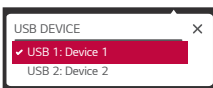

7. If it is not currently selected, use the arrow keys to select **Ez Download**, and then press **OK**.

In the Ez Download screen, a list of files/file types is displayed on the left. Remember that image/icon/video, Pro:Idiom Media Key, STB Software (CPU), and PTC Software files must be stored in the LG_DTV folder and Clone/Configuration (.tlx) files must be stored in the root directory on the USB device.

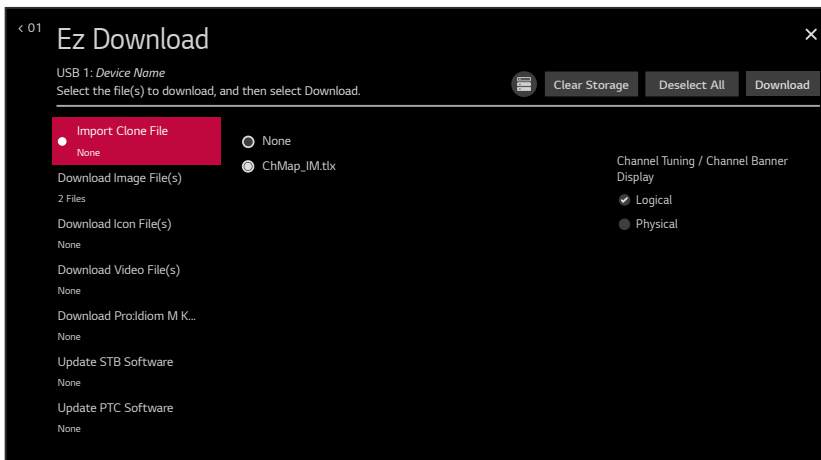

Note: Select the **X** button in the top right corner of the screen, as necessary, to exit the STB Manager. If you accessed the STB Manager via the Solution Settings / EZ-Manager Wizard, you will be returned to the last screen on display before you selected the “USB Configuration” option. If you accessed the STB Manager via the STB menus, you will be returned to program viewing. You can also return/navigate to the STB Manager main screen by selecting **< 01** in the top left corner of the Ez Download screen.

Note: The “Download Pro:Idiom M Key” option only appears if a “.pim” file is detected on the USB device.

(Continued on next page)

Ez Download Utility (Cont.)

(Continued from previous page)

8. To select a file:

- Use the arrow keys on the Installer Remote to select/highlight the appropriate file type field, and then press **OK**.

A list of available files is displayed to the right of the file type fields. In the case of image/icon/video files, once you select the initial “Download Image File(s)” or “Download Icon File(s)” or “Download Video File(s)” option, you will need to also select the appropriate type of image/icon/video file (background image, icon image, etc.) before selecting the image/icon/video file(s) itself/themselves.

- Then, use the arrow keys to select the desired file.

Note: With the exception of background and hotel directory image files, the utility will only allow you to select one of each file type for downloading. For example, if there are two files in the Ez Download “Import Clone File” list, you can only select one or the other of those two files.

Note: The initial default value for each file type is “None.” After the Ez Download utility is run, a file is automatically created and stored on the USB device that was used. The file, which will have a “.dzm” file extension, maintains a history of the file(s) previously used with the Ez Download utility. The next time(s) you use this USB device with the Ez Download utility, the file(s) selected for the last download will be pre-selected for the current download, thus facilitating the process of configuring additional STB-6500s using the same USB device. If you ever want to restore the file selections on the Ez Download screen to “None,” select the **Deselect All** button and press **OK**.

Note: The current STB software (CPU) or PTC software version is always displayed above the listing of available STB software and PTC software files, respectively. Ensure the software version of the selected file is the correct version before applying the update to this STB.

Note: You can select the  (Storage) button at the top of the Ez Download screen to check the amount of storage available for and currently in use by media (image, icon, and video) files. Storage data will be displayed in a pop-up window. When you are finished, select **OK** to close the pop-up window. If you would like to clear all of the media files currently in storage, select the **Clear Storage** button. Then, in the confirmation pop-up window, select **Yes** to clear all of the media files, or select **No** to return to the Ez Download screen without clearing the media files.

9. If a Clone/Configuration (.tx) file that includes an FTG Channel Map is selected, a Channel Tuning / Channel Banner Display field will be displayed at the right of the screen. If the FTG Channel Map comprises RF channels and Aux inputs *only* (the latter designated by 130-0 through 137-0), you can choose the format for the channel tuning/banner display. Use the arrow keys on the Installer Remote to select **Logical** tuning or **Physical** tuning. A checkmark will appear at the left of the selected option. Logical tuning is selected by default.

Note: If an FTG Channel Map includes IP channels, only logical tuning is available. Also, if the selected “.tx” file does not include an FTG Channel Map, the message, “No Channel Map in Clone file,” will be displayed at the right of the screen.

(Continued on next page)

(Continued from previous page)

10. When you are ready to continue, use the arrow keys on the Installer Remote to select **Download**, and then press **OK**.

Download/update progress will be shown in a new screen. Do NOT remove the USB device while downloads/updates are in progress. When the Ez Download process is complete, an overview of the results will briefly be displayed and then, the STB will reboot.

11. Remove the USB memory device, and verify that the appropriate configuration/download(s)/update(s) is/are resident on the STB.

Note: If you updated the STB configuration with a Clone/Configuration file, upon restart (and, if applicable, confirmation of new video output resolution—see note below), the STB tunes according to the Start Channel setting in the Installer Menu. If a Start Channel is specified, the STB will tune to that channel, though in the case of FTG Mode configuration, a channel banner will only be displayed if the Start Channel is included in the FTG Channel Map (depending on your selection in step 9, the channel banner will display either the Start Channel's logical channel number or physical RF channel number). Otherwise, the STB will either return to the last channel tuned (STB in Pass-through Mode) or tune to the first channel in the FTG Channel Map (STB in FTG Mode). In the latter case, remember that the channels in the FTG Channel Map are always arranged in logical order, regardless of your selection in step 9.

Note: If you updated the STB configuration with a Clone/Configuration file that included a change to Installer Menu item 105 VID OUT FORMAT, when the reboot is complete, you will be prompted to confirm the new video output resolution. See item 105 description on page 60 for further information.

Installer Menu

Use the Installer Menu to set up, change, or view operational settings. This section describes how to access, use, and exit the Installer Menu on location; however, you should also refer to the Installer Menu descriptions in this document if you are configuring the STB using an FTG Configuration (.tfx) file created using LG's Cloud Configuration Tool.

Refer to the table on pages 52 to 54 for brief descriptions of Installer Menu items. More detailed descriptions follow the table listing.

Accessing the Installer Menu

1. Turn ON the STB/display panel.

If the EZ-Manager Wizard appears on the screen when you turn ON the STB/display, exit the wizard.

2. Using an Installer Remote, press **MENU** repeatedly until the on-screen display of the setup menus (if the STB is in Pass-through Mode) or the Function Menu (if the STB is not in Pass-through Mode) no longer toggles, and then press the STB Installer Menu entry sequence (e.g., **9-8-7-6**) + **EXIT** to access the STB Installer Menu.

Note: The default Installer Menu entry sequence is "9876"; however, if Installer Menu item 000 INSTALLER SEQUENCE has been modified, the entry sequence may be one of three additional options. See Installer Menu detailed descriptions for further information.

The Installer Menu opens with item 000 INSTALLER SEQ 000.

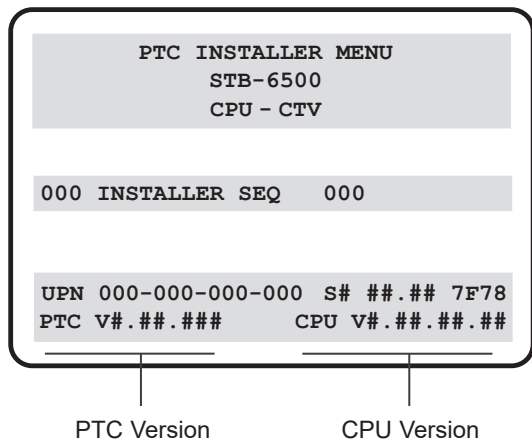

Typical Installer Menu

The menu header identifies this as the STB-6500 Installer Menu. In the Installer Menu footer, you can see the current software versions of the STB, as indicated.

Note: If the password (entry sequence) is not entered or registered correctly, you will see the message "ENTER STB PASSWORD 0000" at the top of the screen instead of the STB Installer Menu header. Once you re-enter the correct password (e.g., press 9-8-7-6 + EXIT), the STB Installer Menu will display.

Note: If an LG Hospitality TV (for example, LW570H, UW660H, etc.) is being used as the display panel (connected to MPI/MTI TELEVISION CONTROL on the STB) and you press the TV Installer Menu entry sequence + OK, you will access the TV's Installer Menu instead of the STB's Installer Menu. The TV's Installer Menu is accessible as read-only while the STB is in control of the display.

Note: If the STB is not in Pass-through Mode, the Installer Menu is accessible as read-only. Also, the STB Zone # will be indicated in the Installer Menu header under the configuration mode indicator described on the following page.

As part of the Installer Menu header (in all modes), two 3-character acronyms are displayed to indicate the STB's current configuration mode. The table below lists all possible mode identifiers for the STB-6500.

Acronym	Description
CPU-CTV	(Default) Pass-through Mode with or without Channel Lineup in CPU
CPU-FTG	FTG Mode via CPU
CPU-P:C	Application Tuning Mode via CPU
MPI-EXT	External MPI Control
PTC-CTV	Pass-through Mode with Channel Map in PTC

Navigating Within the Installer Menu

Use the Up/Down arrow keys on the Installer Remote to sequence through the available menu items, or access an item directly by keying in the item number and then pressing **MENU**. For example, to access the SLEEP TIMER option, which is item 015, press 0-1-5 + MENU.

Installer Menu items not relevant to the STB are not present in the Installer Menu; therefore, some numbers are missing. For example, item 006 will not appear. In addition, items that are dependent on other Installer Menu item settings will not be initially accessible. For example, item 046 STRT AUX SRCE will not display in the Installer Menu unless item 004 STRT CHANNEL is set to 0. See Installer Menu detailed descriptions for further information.

Modifying Installer Menu Settings

Refer to the table starting on the next page for an overview of the available Installer Menu items, including their item numbers, functions, value ranges, and default values.

To change an Installer Menu item value, use the Left/Right arrow keys on the Installer Remote to select the appropriate value, or direct enter a valid value. To save the new setting, press **OK** once on the Installer Remote. If you have additional items to modify, use the Up/Down arrow keys to navigate to a new Installer Menu item or access an item directly as described in the previous section. Note that invalid values will not be saved.



Caution: In order for Installer Menu item changes to be saved, you must press **OK** as indicated above and then exit the Installer Menu as described below. Never remove power from the STB while in the Installer Menu. Also, remember that Installer Menu settings may affect options available from the STB setup menus or the Function Menu.

Exiting the Installer Menu and Activating Settings

After you have saved all desired Installer Menu item changes (i.e., press **OK** once on the Installer Remote to save changes), press **OK** again to exit the Installer Menu. Any changes you make will be stored in non-volatile memory.

Note: Each time you exit the Installer Menu in Pass-through Mode, all V-Chip (Parental Control) settings in the STB are reset to their default values; that is, the Lock System, if previously enabled from the Safety Menu, will now be disabled, and the individual Parental Control settings will be restored to default values.

Installer Menu (Cont.)

Installer Menu Items 000 through 041

Item	Function	Value Range	Default Value	Brief Description of Function
000	INSTALLER SEQ	0–3	0	Leave default set to 0.
001	POWER MANAGE	0–15*	0	Selects the number of hours of inactivity allowed before the STB automatically turns itself OFF and also determines the availability of the Force STB Reboot with IR Remote feature. See detailed descriptions.
002	AC ON	0–3, 16–19	0	Determines the status of the STB/display panel (ON, Instant ON enabled, etc.) when AC power is applied. See detailed descriptions.
003	BAND/AFC	0–3	1	Selects the RF Tuning Band: 0=Broadcast, 1=CATV, 2=HRC, 3=IRC
004	STRT CHANNEL	0–127, 253, 255	255	Channel tuned when the STB/display panel is turned ON. (Set to 255 to tune to channel tuned before the STB/display was turned OFF.)
005	CHAN LOCK	0 / 1	0	If set to 1, cannot tune from current channel.
007	STRT VOLUME	0–63, 255	255	Volume level when the STB/display panel is turned ON. (Set to 255 to use volume level before the STB/display was turned OFF.)
008	MIN VOLUME	0–63	0	Sets the minimum allowable volume setting.
009	MAX VOLUME	0–63	63	Sets the maximum allowable volume setting.
010	MUTE DISABLE	0–3**	0	Determines the status of the sound Mute function and the visibility of the Volume Mute icon. See detailed descriptions.
011	KEY DEFEAT	0 / 1	0	If set to 1, menu navigation buttons/functions on LG Hospitality and commercial non-LG display panels are not functional/available. N/A for LG Public Displays or LG Commercial Monitors.
015	SLEEP TIMER	0 / 1	1	Set to 1 to enable the Sleep Timer feature.
016	EN. TIMER	0 / 1	0	Set to 1 to enable On/Off timers.
017	ALARM	0 / 1	1	Set to 1 to enable the Alarm feature in the Function Menu.
020	FEATURE LEVEL	0–3, 16–31, 64–67†	0	Determines an additional IR code scheme to which the STB will respond. See detailed descriptions.
021	V-CHIP	0 / 1	1	Set to 1 to enable V-Chip (Parental Control) functions.
022	MAX BLK HRS	0–99	12	Determines the number of Parental Control blocking hours that can be set in the Function Menu.
023	POWER ON CC	0–2††	0	Set to 1 to retain the closed caption setting selected before the STB/display panel was turned OFF. Set to 2 to specify closed caption settings, for both analog and digital channels, when the STB/display panel is turned ON.
028	CH. OVERRIDE	0 / 1	1	If set to 0, end users can only tune to channels that are included in the PTC Channel Map. See detailed descriptions.
029	REMAP AUX INPS	0 / 1	0	Set to 1 to remap the PTC's direct tune channels for STB Aux inputs from 13x to 9x.
030	EXTCTL/ACKMASK	0–5‡	0	Enables/disables the ACK Mask feature of MPI and depending on mode, allows external control. See detailed descriptions.
031	POLL RATE	20–169	94	Selects the poll rate for MPI.
032	TIMING PULSE	186–227	207	Sets the baud rate for MPI.
035	HDMI1 ENABLE	0–2	1	Set to 0 to disable STB HDMI 1. Set to 1 (DTV Mode) or 2 (PC Mode), as applicable, to enable STB HDMI 1.
039	REAR AUX EN.	0 / 1	1	Set to 1 to enable the display panel AV input jack.
041	SIMPLINK EN	0 / 1	0	Determines the status of the SIMPLINK feature. See detailed descriptions.

* Values 8 to 15 applicable with PTC v1.00.028 or later. ** Values 2 and 3 applicable with CPU v3.44.60 or later and PTC v1.00.015 or later.

† Values 25–31 applicable with PTC v1.00.010 or later; values 1, 2, and 64 to 66 applicable with PTC v1.00.019 or later; and values 3 and 67 applicable with PTC v1.00.31 or later.

†† Value 2 applicable with PTC v1.00.015 or later. ‡ Values 2 to 5 (Ext Ctrl) applicable with CPU v3.48.50 or later and PTC v1.00.029 or later.

Installer Menu Items 042 through 104

Item	Function	Value Range	Default Value	Brief Description of Function
042	AUTO INPUTS	0–255	0	Determines the STB Aux inputs for which auto-sensing is enabled. See detailed descriptions.
046	STRT AUX SRCE	1, 3, 5, 7, 255	255	Sets the starting STB Aux source (if item 004 STRT CHANNEL is set to 0).
047	AUX STATUS	0 / 1	0	Controls the MPI status channel response for STB Aux sources. Set to 1 for the STB Aux source to be reported as its channel number.
049	DIS. AUDIO M.	0–11, 16, 17	0	Determines the availability of the Sound Out (Audio) Menu in the STB menus, as well as the default Audio Mode when STB is turned ON. See detailed descriptions.
053	DIS. CH-TIME	0 / 1	0	Set to 1 to disable display of the STB's native Channel-Time banner.
069	EN. CH-T COL.	0 / 1	1	Set to 1 to enable custom color for MPI display characters.
070	FOR. CH-TIME	0–7	2	Chooses custom foreground color for MPI display characters.
071	BCK. CH-TIME	0–7	2	Chooses custom background color for MPI display characters.
073	CH NOT AVBLE	0 / 1	0	If set to 1 and item 028 CH. OVERRIDE is set to 0, a "CHANNEL NOT AVAILABLE" message is displayed if the end user attempts to direct tune a channel that is not included in the channel lineup.
075	REVERT CH	0 / 1	0	If set to 1 and loss of MPI communication occurs, STB tunes to the Start Channel.
078	UPN MSB	0–255	0	User programmable number, most significant byte.
079	UPN MSB-1	0–255	0	User programmable number, most significant byte - 1.
080	UPN MSB-2	0–255	0	User programmable number, most significant byte - 2.
081	UPN LSB	0–255	0	User programmable number, least significant byte.
082	CHKSUM ERROR	0 / 1	1	Enforces rigid MPI checksum.
083	HANDSHK TIME	0–5	5	Determines the MPI timing requirement of an MPI command to follow an MPI Status Response.
084	PERMANENT BLK	0 / 1	0	Set to 1 to remove the blocking hours setting in the Function Menu for Parental Control and make the block permanent.
088	EN NOISE MUTE	0 / 1	1	(Analog channels only) If set to 1, audio is muted if no signal is present.
090	KEY LOCK	0 / 1	1	If set to 1, all LG Hospitality and commercial non-LG display panel button functions are locked. N/A for LG Public Displays or LG Commercial Monitors.
091	HDMI2 ENABLE	0–2	1	Set to 0 to disable STB HDMI 2. Set to 1 (DTV Mode) or 2 (PC Mode), as applicable, to enable STB HDMI 2.
092	HDMI3 ENABLE*	0–2	0	Set to 0 to disable STB HDMI 3. Set to 1 (DTV Mode) or 2 (PC Mode), as applicable, to enable STB HDMI 3.
094	SAP MENU EN	0 / 1	1	Set to 1 to enable the SAP feature in the Function Menu.
096	DEF. ASP. RATIO	0–4	2	Sets the default aspect ratio. See detailed descriptions.
097	AUDIO OUTPUT	0, 9, 10	9	Set as required in accordance with external audio equipment connected to the STB. See detailed descriptions.
098	PRO:CENTRIC	0, 2, 3	0	Set to 0 to disable Pro:Centric operation. Set to 2 for GEM (Java Application) Mode. Set to 3 for HTML Mode.
100	VIDEO INTERFAC	3–5	3	Selects the HDMI connection for display panel: 3 = HDMI 1, 4 = HDMI 2, 5 = HDMI 3
101	IR FEEDBACK	0 / 2	0	Set to 2 to disable the STB's MMR feature.
102	ATSC BAND	0–4	4	Selects the RF band used by the ATSC tuner. See detailed descriptions.
103	ATSC TUNE MODE	0 / 1	1	Set to 1 (default) for Physical Channel tuning. Set to 0 for Virtual Channel tuning.
104	START MINOR CH	0–255	0	Selects the Minor Start Channel number. Set to 0 for analog (NTSC) channel.

* HDMI 3 port on expansion interface connector.

Installer Menu (Cont.)

Installer Menu Items 105 through 122

Item	Function	Value Range	Default Value	Brief Description of Function
105	VID OUT FORMAT	1, 4, 5, 6	4	Sets the format for video output: 1 = 720p, 4 = 1080p, 5 = 1366 x 768, 6 = 2160p
106	ASP RATIO LOCK	0 / 1	0	Set to 0 to use the default aspect ratio each time the STB/display panel is turned ON. Set to 1 to retain the aspect ratio set before the STB/display panel was turned OFF.
107	BANNER SELECT	0 / 1	1	Selects the type of native Channel-Time banner to display during channel change.
108	PANEL COM	0–3	2	Set to match the display panel baud rate: 0 = 1200, 1 = 2400, 2 = 9600, 3 = 115200
110	PANEL DELAY	1–15	8	Sets the display panel communication delay time. See detailed descriptions.
	PANEL INST ON	0 / 1	0	Controls the STB's display panel Instant ON feature. See detailed descriptions.
111	PANEL VOL PRE	0–100	100	Determines a preset fixed volume level to set in the display panel.
113	PANEL TYPE	0–4	4	Sets the display panel communication command set. See detailed descriptions.
116	VIDEO MUTE EN	0 / 1	0	(Analog channels only) If set to 1, video mutes (blank screen) when no signal is present.
117	FACT DEFAULT	0 / 1	0	Set to 1 to restore the factory default settings of all Installer Menu items.
119	DATA CHANNEL	0–135, 253, 254, 255*	255	Set to 0 to disable. Set from 1 to 135 to match the RF channel number used by the Pro:Centric server as its data channel. Set to 255 to use Auto Search to find the Pro:Centric RF channel. See detailed descriptions.
121	UPDATE TIME HR	0–23, 128, 255	128	Sets the Wake For Update hour. See detailed descriptions.
122	UPDATE TIME MN	0–59, 255	0	Sets the minute for Wake For Update. See detailed descriptions.

* Value 254 applicable with CPU v3.44.60 or later and PTC v1.00.010 or later.

Detailed Descriptions of Installer Menu Items

000 - INSTALLER SEQUENCE

Specifies entry sequence to the Installer Menu.

0 = 9876 1 = 4321
2 = 1478 3 = 3698

001 - POWER MANAGE (Power Management)

As an energy saving feature, this item determines the number of hours, in the range 1 to 7, of inactivity allowed, either at the display control panel or from the remote, before the STB automatically turns itself OFF.

In addition to Power Management setting, values 8 to 15 determine the availability of the Force STB Reboot with IR Remote feature when Installer Menu item 002 AC ON is set to 1 or 17 (Always ON) or 3 or 19 (Instant ON without reboot) (see also item 002 description). While the STB/display panel is ON, perform the following steps to force the reboot: Press and hold the POWER key on the Installer Remote for at least five seconds, and then press the MENU key within two seconds of releasing the POWER key. During the reboot process, the STB will initiate an update event (see also item 121 UPDATE TIME HR description). After reboot, the STB returns to its ON state.

See table below for all values. If set to 0 or 8, Power Management is disabled.

Values	Power Mgmt	Force STB Reboot	Values	Power Mgmt	Force STB Reboot
0	Disabled	Disabled	8	Disabled	Enabled
1	1 hour	Disabled	9	1 hour	Enabled
2	2 hours	Disabled	10	2 hours	Enabled
3	3 hours	Disabled	11	3 hours	Enabled
4	4 hours	Disabled	12	4 hours	Enabled
5	5 hours	Disabled	13	5 hours	Enabled
6	6 hours	Disabled	14	6 hours	Enabled
7	7 hours	Disabled	15	7 hours	Enabled

Note: Values 8 to 15 are applicable with PTC v1.00.028 or later.

002 - AC ON (AC Power Switchable)

Determines the status of the STB/display panel when AC power is applied. Set to 0 (default) for standard STB/display panel turn ON/OFF operation. Set to 16 if you would like the STB/display panel to turn ON the first time AC power is applied, after which the STB/display will be configured for standard ON/OFF operation.

If set to 1 or 17 (Always ON), the STB/display panel will turn ON when AC power is applied. Pressing the POWER button is not necessary. This is desirable if the STB is plugged into a switched AC outlet. Though note that if the Pro:Centric application is loaded (i.e., item 98 PRO:CENTRIC is not set to 0), the STB will reboot and initiate an update event once every 24 hours.* During the update event, the STB checks for and downloads any available updates from the Pro:Centric server (item 119 DATA CHANNEL set from 1 to 135, 253, or 254). The time at which this event occurs depends on the setting of item 121 UPDATE TIME HR. See item 119 and 121 descriptions for further information. Once the update cycle is complete, the STB completes the reboot and returns to its ON state.

Note: If set to 1 or 17, the STB does not respond to ON/OFF commands from the remote, and the Sleep Timer is nonfunctional. Set to 2, 3, 18, or 19 to enable the Instant ON feature as required. The Instant ON feature allows the STB to turn ON when AC power is applied, while the display panel remains OFF. The STB remains powered ON, and pressing the POWER button only toggles the display panel on and off. Set to the appropriate value to enable Instant ON with reboot (value 2 or 18) or Instant ON without reboot (value 3 or 19), respectively. See bullets below for further information on reboot functionality. See also note below.

Note: Values 2 and 3 represent standard Instant ON functionality; i.e., when AC power is applied, the STB is ON, while the display panel remains OFF. If set to 18 or 19, the Instant ON feature allows the STB and also the display panel to turn ON when AC power is initially applied.

- Instant ON with reboot: The STB will reboot and, if applicable (i.e., item 119 set from 1 to 135, 253, or 254), check for and download any available updates from the Pro:Centric server each time the display panel is turned OFF. This setting is not recommended if the STB will be configured with a resident application.
- Instant ON without reboot: The STB will not reboot to check for and download updates each time the display panel is turned OFF, with the following exception: the first time the display is turned OFF after this item is set to 3 or 19, the STB will reboot and initiate an update event (Data Channel Auto Search and/or check for and download of updates—see also paragraph below). This setting is recommended if the STB will be configured with a resident application. In this mode, the standard check for and download of updates is under application control. Refer to your site-specific documentation for further information on configuring the STB with a resident application.

When this item is set to 2, 3, 18, or 19, the STB also will reboot and initiate an update event once every 24 hours. During the update event, the STB, as applicable, performs a Data Channel Auto Search (item 119 set to 255) and/or checks for and downloads any available updates from the Pro:Centric server (item 119 set from 1 to 135, 253, or 254). The time at which this event occurs depends on the setting of item 121 UPDATE TIME HR. See item

119 and 121 descriptions for further information. Once the update cycle is complete, the STB completes the reboot and returns to its ON state with the display panel OFF.

Note: See also Installer Menu item 110 PANEL INST ON to enable the STB's Instant ON control of the display panel.

Note: Instant ON is not supported when the STB is in MPI-EXT Mode.

003 - BAND/AFC (Tuning Band)

Selects the RF band used by the NTSC tuner:

0 = Broadcast	1 = Cable (default)
2 = HRC	3 = IRC

Determine the RF band used by the RF distribution system, and then select the appropriate value for this item before tuning channels or running Channel Tuning (Channel Search). See also item 102 ATSC BAND.

004 - STRT CHANNEL (Start Channel)

If active, this function allows you to determine the initial Major Start Channel number when the STB/display panel is turned ON. This feature is useful for an in-house information channel, since the STB/display would always select that channel when it is turned ON. If set to 255, the last channel tuned before the STB/display was turned OFF will be the channel tuned when the STB/display is turned ON again.

0 = Aux	127 = Map to Major CH 4
1 – 125 = Major Ch. #	253 = IP Start Channel
126 = Map to Major CH 3	255 = Last Channel

For a digital (ATSC) Start Channel, always remember to set item 104 to the Minor Start Channel number. If setting this item to 0 (Aux), make sure to also set item 046 STRT AUX SRCE to the appropriate value.

Note: 126 and 127 are mapped only in SONIFI PPV Mode.

Note: The IP Start Channel shown above can only be set in the Cloud Configuration Tool, which is typically used to configure STB CPUs for FTG Mode. The same applies for the additional Major Channel number range of 128–135 in Physical tuning and 128–999 in Virtual tuning mode. When the STB is in FTG Mode, the appropriate values will be visible in the (read-only) Installer Menu. For an IP Start Channel, item 004 will show value 253, the IP address, and the port number. For an RF Start Channel, item 004 will show the channel's Major and Minor numbers.

Note: If the STB is being configured for Application Tuning Mode operation with Pro:Centric Direct, the Start Channel is set in the Pro:Centric Direct Admin Client, and Installer Menu item 004 is automatically updated accordingly. When the STB is in Application Tuning Mode, the appropriate values will be visible in the (read-only) Installer Menu. For an IP Start Channel, item 004 will show value 253, the IP address, and the port number. For an RF Start Channel, item 004 will show the channel's Major and Minor numbers.

* Exception: If the STB is externally rebooted within the previous 24 hours, the subsequent update event will take place at the next designated reboot time, which could be up to 48 hours from the time of the external reboot.

Installer Menu (Cont.)

005 - CHAN LOCK (Channel Lock)

Channel Lock is ideal if the system must always be on the same channel. Changing channels with the Channel Up/Down or keypad numbers is impossible. Channel Lock is inactive if set to 0 (default).

Generally, this feature is used in connection with item 004 STRT CHANNEL where the Start Channel may, for example, be set to 3 or 4. If the Start Channel is 3, then the STB will remain locked on channel 3.

NOTE: For items 007, 008, and 009

For legacy reasons, the scale used is 0–63. The PTC software will translate this to the 0–100 scale used by the STB.

To translate an STB volume level to the Installer Menu value, use the following formula:

$$\text{Installer Value} = \frac{\text{STB Value} \times 63}{100}$$

Enter only the whole number (disregard fractions).

007 - STRT VOLUME (Start Volume)

This function allows you to determine the initial volume level setting on the STB/display panel when it turned ON. The range of values for this item is 0 to 63, 255. If set to 255, the last STB volume level before the STB/display was turned OFF will be the current volume level when the STB/display is turned ON again.

Note: The factory default STB volume level (i.e., when AC power is initially applied) for the STB-6500 is 20. In addition, if AC power is removed/disconnected and then reapplied to the STB while this item is set to 255, the STB volume level will revert to 20 when the STB/display is turned ON again, with the following exceptions: for item 002 AC ON settings 16–19, the STB volume level will remain at the last volume level.

008 - MIN VOLUME (Minimum Volume)

This function determines the minimum volume level allowable with the Volume (VOL) Up/Down control. In this way, for example, someone cannot set the volume too low to hear. The value range for this item is from 0 to 63. The factory default is 0, which provides the full range of STB volume control, if item 009 MAX VOLUME is set to 63. It is recommended to set the same value on every STB.

Note: The minimum volume level cannot have a value setting higher than the maximum volume level (described below).

009 - MAX VOLUME (Maximum Volume)

This function determines the maximum volume level allowable with the Volume (VOL) Up/Down control. In this way, for example, someone cannot set the volume level high enough to disturb others. The value range for this item is 0 to 63, with 63 as the default, which provides the full range of STB volume control, if item 008 MIN VOLUME is set to 0. It is recommended to set the same value on every STB.

Note: The maximum volume level cannot have a value setting lower than the minimum volume level (described above).

010 - MUTE DISABLE

Enables or disables the sound Mute function. If set to 0 or 2, sound can be muted. If set to 1 or 3, sound cannot be muted. If set to 2, when the STB volume is either 0 or muted, the Volume Mute icon will remain visible on the screen. If set to 3, when the STB volume is 0, the Volume Mute icon will remain visible on the screen.

Note: Values 2 and 3 are applicable with CPU v3.44.60 or later and PTC v1.00.015 or later.

011 - KEY DEFEAT

Applicable for LG Hospitality and commercial non-LG display panels only. If set to 1, Key Defeat is enabled, which means that end users cannot access or navigate within the STB's on-screen menu(s) from the display panel; i.e., menu navigation buttons will not function. Set to 0 to disable Key Defeat. Note that all IR features remain functional regardless of this setting; users can always access the STB's menus by pressing MENU on the remote.

Note: This feature does not apply to LG Public Displays or LG Commercial Monitors since the STB will always disable those displays' panel buttons and the processing of IR.

015 - SLEEP TIMER

If set to 1, the Sleep Timer feature is enabled and available to the end user. Set to 0 to disable the Sleep Timer feature.

016 - EN. TIMER (Enable On/Off Timers)

If set to 1, the Timer function is enabled and available to the end user. Set to 0 to disable On/Off timers.

Note: The STB clock must be set in order for timers to be used.

017 - ALARM

If set to 1, the Alarm feature is enabled and available to the end user in the Function Menu (i.e., the STB is not in Pass-through Mode). Set to 0 to disable the Alarm feature.

Note: The STB clock must be set before the Alarm feature will work.

020 - FEATURE LEVEL

Determines an additional IR code scheme to which the STB will respond, allowing for the use of unique IR codes based on “bed number” in a multi-STB/display single room installation. First determine the IR mode; then select the bed number.

Values	IR Mode	Bed #	Speaker
0–1	Zenith*	1–2	TV Only
2	IMX**	N/A	TV Only
3	Zenith 6-bit**	N/A	TV Only
16–31	Multi-code Remote	1–16	TV Only
64–65	Zenith*	1–2	Pillow Only
66	IMX**	N/A	Pillow Only
67	Zenith 6-bit**	N/A	Pillow Only

* Decoded internally or supported with custom remote registration.

** Only supported with custom remote registration.

Note: Values 25–31 are applicable with PTC v1.00.010 or later. Values 1, 2, and 64 to 66 are applicable with PTC v1.00.019 or later. Values 3 and 67 are applicable with PTC v1.00.031 or later.

Note: The LG Slate-RX remote control is required for multi-code functionality. For further information, see Reference section, “LG Slate-RX Lodging Remote.”

021 - V-CHIP (Parental Control)

Set to 1 to activate V-Chip (Parental Control) and have it available to the end user to filter and control or otherwise restrict programming content that can appear. Set to 0 to turn off the V-Chip feature (not available to end user); no programming restrictions can be set.

022 - MAX BLK HRS (Maximum Block Hours)

Sets hours from 0 to 99 for the maximum number of Parental Control blocking hours that can be set in the Function Menu (i.e., the STB is not in Pass-through Mode). Default setting is for 12 blocking hours.

Note: This item is not available in the Installer Menu when item 021 V-CHIP is set to 0 or when item 084 PERMANENT BLK is set to 1.

023 - POWER ON CC

If set to 0, closed captions are off when the STB/display panel is turned ON. If set to 1, the closed caption setting selected before the STB/display was turned OFF will be the current caption setting when the STB/display is turned ON again.

Set to 2 (Start) to specify closed caption settings, for both analog and digital channels, when the STB/display panel is turned ON. When this item is set to 2, a submenu is displayed in the Installer Menu, and you can select the desired closed caption start setting for analog and digital channels, as indicated in the table below.

023 POWER ON CC 002 Start

ANALOG CC 3 CC1

DIGITAL CC 0 Off

Values	Analog Channel CC
0	CC1 (default)
1	CC2
2	CC3
3	CC4
4	Text1
5	Text2
6	Text3
7	Text4

Values	Digital Channel CC
0	Off (default)
1	Service 1
2	Service 2
3	Service 3
4	Service 4
5	Service 5
6	Service 6

Note: When “Off” is selected as the digital channel closed caption setting, the closed captions for digital channels will be the same as the setting for analog channel closed captions.

To access the submenu, with item 023 on display in the Installer Menu, press **MENU** on the Installer Remote (without pressing a numeric key before it). Once in submenu, use the Up/Down arrow keys on the Installer Remote to navigate between the ANALOG CC and DIGITAL CC fields, and use the Left/Right arrow keys to select the appropriate value in each field. To exit the submenu and return to the main menu item 023, press **MENU** again.

Note: Value 2 is applicable with PTC v1.00.015 or later. The submenu shown above is only displayed when value 2 is selected.

028 - CH. OVERRIDE (Channel Override)

This item either allows or restricts tuning of channels that are NOT in the PTC Channel Map. If set to 1, end users can tune channels that are not in the PTC Channel Map by direct keypad entry. If set to 0, end users are restricted to only the channels that are in the PTC Channel Map. In the case of CPU-CTV Mode, there are no channels in the PTC Channel Map; therefore, direct keypad entry is not available. Also, when this item is set to 0, the PTC Channel Map (PTC-CTV Mode)/CPU channel lineup (CPU-CTV Mode) is locked, and end user access to channel settings in the STB setup menus is restricted.

Note: This item is not applicable when the STB is in FTG Mode or Application Tuning Mode.

029 - REMAP AUX INPS

Set to 1 to remap the PTC’s direct tune channels for STB Aux inputs from 13x to 9x. This allows 2-digit only tuning systems (i.e., legacy On Command Video™) to direct tune STB Aux inputs. See also Reference section, “STB Aux Input Configuration.”

Note: This item is not applicable when the STB is in FTG Mode or Application Tuning Mode.

Installer Menu (Cont.)

030 - EXTCTL/ACKMASK

Determines status of MPI ACK Mask feature, as well as availability of external control either via MPI (using External MPI Control port) or via TLT (using External RS-232C Control port). See table below.

Values	External Control Port				ACK Mask Feature
	CPU-CTV Mode		CPU-FTG / CPU-P:C Mode		
	External MPI Control	External RS-232C Control	External MPI Control	External RS-232C Control	
0	O	O	X	X	Disabled
1	O	O	X	X	Enabled
2	O	X	O	X	Disabled
3	O	X	O	X	Enabled
4	X	O	X	O	Disabled
5	X	O	X	O	Enabled

O = Available X = Prohibited

Note: Values 2 to 5 (Ext Ctrl) are applicable with CPU v3.48.50 or later and PTC v1.00.029 or later.

031 - POLL RATE

MPI Communication Parameter. Selects the poll rate for MPI. Step size of 16 ms. Changing from default may affect communication via MPI.

032 - TIMING PULSE

MPI Communication Parameter. Sets the baud rate for MPI. Step size of 4.3 uS. Changing from default may affect communication via MPI.

035 - HDMI1 ENABLE

Set to 1 to enable STB HDMI 1 input in DTV Mode. Set to 2 to enable STB HDMI 1 input in PC Mode. Set to 0 to disable STB HDMI 1 input.

039 - REAR AUX EN. (Rear Aux Enable)

Set to 1 to enable STB Aux (AV) input. Set to 0 to disable STB Aux (AV) input.

041 - SIMPLINK EN

Set to 0 to disable the SIMPLINK feature. Set to 1 to enable SIMPLINK functionality (does not enable remote control access to the SIMPLINK Menu).

Note: When both this item *and* item 042 AUTO INPUTS are enabled in the Installer Menu, HDMI inputs will be detected by SIMPLINK, but the Auto Input(s) Sensing Feature will not function.

Note: ARC functionality requires that SIMPLINK be enabled.

042 - AUTO INPUTS

Determines the Aux inputs for which auto-sensing is enabled. Set to 0 to disable auto-sensing for all available inputs. Set to 255 to enable auto-sensing for all available inputs. For information on options for individual input settings, see Reference section, "Auto Input(s) Sensing Feature."

Note: In order for auto-sensing to be enabled for an input, that input must also be enabled in the Installer Menu. For example, to enable auto-sensing for HDMI 1, item 035 HDMI1 ENABLE must also be set to 1 or 2. Also, see note above regarding STB operation when both this item and item 041 SIMPLINK EN are enabled.

046 - STRT AUX SRCE (Start Aux Source)

Sets the starting STB Aux source. When turned ON, the STB/display panel will tune to the starting Aux source if item 004 STRT CHANNEL is set to 0.

1 = AV 3 = HDMI 1 5 = HDMI 2
7 = HDMI 3 255 = Last Aux

Note: In order for an Aux input to be selected as the starting Aux source, the input also must be enabled in the Installer Menu.

Note: This item is not available in the Installer Menu unless item 004 STRT CHANNEL is set to 0.

047 - AUX STATUS

Controls the MPI status channel response for STB Aux sources. Set to 1 for the STB Aux source to be reported as its channel number. Set to 0 for the STB Aux source to be reported as channel 0. See Reference section, "STB Aux Input Configuration," for Direct Access channel numbers.

049 - DIS. AUDIO M. (Disable Audio Menu)

Determines the availability of the Sound Out (Audio) Menu in the STB menus. Also determines the default Audio Mode when STB is turned ON. See the table below and set as required.

Value	Sound Out Menu Status	Default Audio Mode at STB Turn ON
0 (default)	Enabled	Display Speaker
1	Disabled	Display Speaker
2	Enabled	External Speaker (Optical*)
3	Disabled	External Speaker (Optical*)
4	Enabled	LG Sound Sync (Optical*)
5	Disabled	LG Sound Sync (Optical*)
6	Enabled	LG Sound Sync (Wireless*/BT*)
7	Disabled	LG Sound Sync (Wireless*/BT*)
8	Enabled	Display Speaker + Audio Out (Optical*)
9	Disabled	Display Speaker + Audio Out (Optical*)
10	Enabled	External Speaker (HDMI ARC*)

11	Disabled	External Speaker (HDMI ARC*)
16	Enabled	Display Speaker + Audio Out (BT*)
17	Disabled	Display Speaker + Audio Out (BT*)

* Connect to/via STB.

Note: If a SIMPLINK-enabled device is connected to the STB and item 041 SIMPLINK EN is set to 1 (enabled), the SIMPLINK device Audio Mode will have priority over the setting of this item when the STB/display is turned ON.

053 - DIS. CH-TIME (Disable Channel-Time Banner)

Set to 1 to disable display of the STB's native Channel-Time banner when a custom channel label/channel information will be provided by the MPI command. Set to 0 to enable display of the STB's native Channel-Time banner.

Note: This item is not applicable when the STB is in FTG Mode or Application Tuning Mode.

069 - EN. CH-T COL. (Enable Display Characters Custom Color)

Set to 1 to enable custom color for MPI display characters. Set to 0 to disable custom color for MPI display characters.

070 - FOR. CH-TIME (Display Characters Foreground Color)

Set the foreground color for MPI display characters according to the following color chart:

0 = Black	2 = Green	4 = Red	6 = Yellow
1 = Blue	3 = Cyan	5 = Violet	7 = White

If the foreground and background colors for the display characters are the same, the background will be transparent.

Note: This item and item 071 BCK. CH-TIME also apply to the "Channel Not Available" message if item 073 CH NOT AVBLE is set to 1 (enabled).

Note: Items 070 FOR. CH-TIME and 071 BCK. CH-TIME are only available in the Installer Menu when item 069 EN. CH-T COL. is set to 1.

071 - BCK. CH-TIME (Display Characters Background Color)

See description for item 070 FOR. CH-TIME above. The color chart is the same for both items.

073 - CH NOT AVBLE (Channel Not Available)

If set to 1 and item 028 CH. OVERRIDE is set to 0, a "CHANNEL NOT AVAILABLE" message is displayed when the end user attempts to direct tune a channel that is not included in the channel lineup.

Note: This item is not available in the Installer Menu when item 028 CH. OVERRIDE is set to 1.

Note: This item is only applicable when the STB is in PTC-CTV Mode.

075 - REVERT CH (Revert to Start Channel)

If set to 1 and loss of MPI communication occurs, the STB automatically tunes to the specified Start Channel.

Note: This item is not available in the Installer Menu when item 004 STRT CHANNEL is set to 255. This item also is not available in the Installer Menu when item 004 STRT CHANNEL is set to 0 and 046 STRT AUX SRCE is set to 255.

078 - UPN MSB (UPN Most Significant Byte)

User programmable number, most significant byte readable by MPI command. Note: Not linked to serial number.

079 - UPN MSB-1 (UPN Most Significant Byte-1)

User programmable number, most significant byte-1 readable by MPI command. Note: Not linked to serial number.

080 - UPN MSB-2 (UPN Most Significant Byte-2)

User programmable number, most significant byte-2 readable by MPI command. Note: Not linked to serial number.

081 - UPN LSB (UPN Least Significant Byte)

User programmable number, least significant byte readable by MPI command. Note: Not linked to serial number.

082 - CHKSUM ERROR (Checksum Error)

Enforces rigid MPI checksum validation. Set to 1 for validation. Set to 0 to disable (does not check checksum on MPI async port). SPI is always checked.

083 - HANDSHK TIME (Handshake Time)

Determines the MPI timing requirement of the (STB's) MPI command to follow the end of the transmission of the (display's) MPI Status Response. Value range is 0 to 5. Changing from default may affect communication via MPI.

(Handshake Time = 25.5 ms + [25.5 ms x item value])

084 - PERMANENT BLK (Permanent Block)

Allows Parental Control blocking schemes to be permanent by disabling the end user's ability to limit blocking hours in the Function Menu. Set to 1 to install Parental Control restrictions permanently. Set to 0 for end user-specified hours control of blocking schemes. See also item 022 MAX BLK HRS.

Note: This item is not available in the Installer Menu when item 021 V-CHIP is set to 0.

088 - EN NOISE MUTE (Enable Noise Mute)

Applicable for analog channels only. If set to 1, audio mutes if no signal is present.

Installer Menu (Cont.)

090 - KEY LOCK

Applicable for LG Hospitality and commercial non-LG display panels only. If set to 1, Key Lock is enabled, which means that all display panel button functions will be locked, i.e., non-functional. Set to 0 to disable Key Lock. Note that all IR features remain functional regardless of this setting.

Note: This feature does not apply to LG Public Displays or LG Commercial Monitors since the STB will always disable panel buttons and the processing of IR on those displays.

091 - HDMI2 ENABLE

Set to 1 to enable STB HDMI 2 input in DTV Mode. Set to 2 to enable STB HDMI 2 input in PC Mode. Set to 0 to disable STB HDMI 2 input.

092 - HDMI3 ENABLE*

Set to 1 to enable STB HDMI 3 input in DTV Mode. Set to 2 to enable STB HDMI 3 input in PC Mode. Set to 0 to disable STB HDMI 3 input.

094 - SAP MENU EN (2nd Audio Program)

Set to 1 to enable the SAP feature in the Function Menu (i.e., the STB is not in Pass-through Mode). Set to 0 to disable the SAP feature in the Function Menu.

096 - DEF. ASP. RATIO (Default Aspect Ratio)

Selects the aspect ratio to be set as default each time the STB/display panel is turned ON:

0 = Set By Program	1 = 4:3	2 = 16:9 (default)
3 = Just Scan	4 = Zoom	

Note: See also item 106 ASP RATIO LOCK. This item (i.e., item 096) is not available in the Installer Menu when item 106 is set to 1.

097 - AUDIO OUTPUT

Determines availability of the analog audio output to be used by external audio equipment connected to the Audio Line Out jack on the STB. Set to 0 to disable audio output. Set to 9 (default) to enable fixed line level (typically 400 mVrms ± 40 mVrms @10KΩ) output. Set to 10 to enable volume control of audio output. See also Reference section, "External Audio Line Out Specifications."

098 - PRO:CENTRIC

Selects the Pro:Centric Application Mode. Set to 0 (default) to disable the Pro:Centric application. Set to 2 for GEM (Java Application) Mode. Set to 3 for HTML Mode.

To initiate the Pro:Centric application download, the STB must be turned OFF/ON two times. Once you exit the Installer Menu, turn OFF the STB/display panel for at least one minute. When you turn the STB/display panel back ON, wait until TV programming appears on the display, and then turn the STB/display panel back OFF, this time for a few minutes, to initiate the application

download. When you turn the STB/display panel back ON, press the PORTAL key on the Installer Remote, and verify that the Pro:Centric application appears on the display.

Note: This item is not available in the Installer Menu when item 119 DATA CHANNEL is set to 0.

100 - VIDEO INTERFAC

Selects the HDMI port on the display panel to be used for HDMI input from the STB. Set to 3 for HDMI 1 (default). Set to 4 for HDMI 2. Set to 5 for HDMI 3.

If you change the value of this item, make sure to reconnect the HDMI cable from the STB to the appropriate HDMI port on the display panel once you have exited the Installer Menu.

101 - IR FEEDBACK

If set to 0 (default), the STB's MMR (Magic Motion Remote) feature is enabled, and a compatible LG MMR (not supplied) may be used with the STB. If set to 2, the MMR feature is disabled.

102 - ATSC BAND

Selects the RF band used by the ATSC tuner.

0 = Broadcast	1 = Cable	2 = HRC
3 = IRC	4 = Same as NTSC (default)	

103 - ATSC TUNE MODE

Sets the ATSC tuning mode. Default set to 1 for Physical Channel tuning. Set to 0 for Virtual Channel tuning.

Note: This item must be set to 1 (Physical Channel tuning) to support Pro:Centric RF data channel operation. See also item 119 DATA CHANNEL.

104 - START MINOR CHANNEL

When a digital (ATSC) Start Channel has been specified for item 004 STRT CHANNEL, this item sets the Minor Start Channel number. Set to 0 when an analog (NTSC) Start Channel has been specified for item 004.

Note: This item is not available in the Installer Menu when item 004 STRT CHANNEL is set to 0 or 255.

105 - VID OUT FORMAT

Selects the format for video output (i.e., the resolution):

1 = 720p	5 = 1366 x 768
4 = 1080p (default)	6 = 2160p

If you change the video output format on location, once you exit the STB Installer Menu, a Changing Video Output Resolution screen will appear at the bottom of the display screen, and then the STB will reboot to change the resolution per your selection. When the reboot is complete, a prompt for confirmation of the new video output resolution will be displayed. To confirm the new video output resolution, use the arrow keys on the Installer Remote to select **Yes**, and then press **OK** on the Installer Remote.

* HDMI 3 port on expansion interface connector.

If there is no user interaction within 10 seconds of the prompt for confirmation, or if you select "No" in the confirmation screen, the STB will reboot and revert to the former resolution.

Note: If this item is updated via a Clone/Configuration (.tlx) file loaded on a Pro:Centric server, no confirmation is required.

Note: Refer to documentation for the applicable display panel(s) to determine the appropriate resolution setting. The selected resolution should be compatible with the display panel's native video output resolution. If necessary/desired, you can use STB Zone designations to create multiple profiles to differentiate item 105 settings by display panel brand. See Reference section, "Using the STB's Zoning Features," for further information on STB Zones.

106 - ASP RATIO LOCK (Aspect Ratio Lock)

Set to 0 to use the default aspect ratio each time the STB/display panel is turned ON (see item 096 DEF. ASP. RATIO). If set to 1, the aspect ratio set before the STB/display panel was turned OFF will be the current aspect ratio when the STB/display panel is turned ON again.

107 - BANNER SELECT

Selects the type of native Channel-Time banner to display during channel change. Set to 1 for channel label display, plus channel information (full banner). Set to 0 for channel label display only (small banner). See also item 053 DIS. CH-TIME.

108 - PANEL COM (Panel Communication)

Applicable only for LG Public Display TVs and Commercial Monitors that use the RS-232C TELEVISION CONTROL port for STB-to-display panel communication. Set to match the display panel baud rate:

0 = 1200	1 = 2400
2 = 9600 (default)	3 = 115200

110 - PANEL DELAY

For all display panels with the exception of LG Hospitality/MPI display panels, after the STB sends the turn ON command to the display panel, the display panel requires time to complete its power on sequence before it begins accepting commands from the STB. This item sets the time, in seconds, to delay the STB's subsequent communication with the display panel. The default value is 8 seconds. See also item 110 PANEL INST ON description below. A second item 110 value allows you to enable the STB's display panel Instant ON feature for LG displays.

For all display panels, this item (PANEL DELAY) also sets the amount of elapsed time required before the STB accepts successive POWER key presses. That is, if this item is set to 8 seconds, and you press the POWER key to turn ON the STB, you will need to wait 8 seconds for the STB to accept the POWER key again if you then decide you want to turn OFF the STB.

Note: The amount of time required for the display's power on sequence varies by display panel brand/model. Thus, depending on the brand/model of display panel connected to the STB, you may be able to decrease or you may need to increase the Panel Delay value, accordingly. For example, if you are using the STB with an LG PW1000 or PW1500 projector, it is recommended that you set the delay to 10 or more seconds.

110 - PANEL INST ON

See also item 110 PANEL DELAY description above. This is a second item 110 value that enables the STB to control an LG display panel, such that it turns ON instantly, as described below (see also note regarding non-LG display panel exception).

When item 002 AC ON is set to 2, 3, 18, or 19 (i.e., Instant ON is enabled on the STB), this item determines if the STB is to leave the LG display panel always ON or if the display panel is to be turned OFF when the STB is turned OFF. In the case of the former, the LG display panel is always ON, but video and audio are both muted (i.e., no video is visible and no audio is audible) when the STB is turned OFF. Set to 1 to enable display panel Instant ON.

Note: This feature is not applicable for commercial non-LG display panels. If you replace a non-LG display panel with an LG display panel, make sure to also disable the MTI protocol.

Note: This item is not available in the Installer Menu unless item 002 is set to 2, 3, 18, or 19.

111 - PANEL VOL PRE (Panel Volume Preset)

Determines a preset fixed volume level (gain) to set in the display panel. The audio signal (volume level) is dynamically controlled in the STB. The default value is 100 to provide a typical 1:1 ratio of volume level to sound output when the STB is connected to an LG display panel.

Note: Sound output may vary by display panel brand/model. Thus, depending on the brand/model of display panel connected to the STB, you may need to adjust the preset volume level to achieve the desired sound output.

113 - PANEL TYPE

Sets the TLM command set to communicate with the display panel. This setting is only applicable for LG Public Display TVs and Commercial Monitors that use the RS-232C TELEVISION CONTROL port for STB-to-display panel communication.

The default value (4) will be appropriate for most current display models. See Reference section, "Display Panel Specifications," to determine the appropriate setting for the display panel being used.

Note: If you need to enable the MTI protocol (i.e., the STB is connected to a commercial non-LG display), see Reference section, "Enabling or Disabling the MTI Protocol on the STB," for further information.

Installer Menu (Cont.)

116 - VIDEO MUTE EN (Video Mute Enable)

Applicable for analog channels only. If set to 1, video mutes (blank screen) when no signal is present.

117 - FACT DEFAULT (Factory Default)

Set to 1 and press OK to restore the factory default settings of all Installer Menu items. Once complete, the value returns to 0.



Caution: If set to 1, this clears all STB Installer Menu custom settings and restores the factory default settings. It also clears the channel lineup, including any assigned channel icons and custom text labels.

Note: See also Reference section, “Restoring Factory Defaults on the STB(s),” for further information.

119 - DATA CHANNEL

Set to 0 to disable. Set from 1 to 135 to match the (physical) RF channel number that will be used by the Pro:Centric server as its data channel. If left at or set to the default value (255), the STB’s Data Channel Auto Search feature will be enabled. See additional information below.*

Data Channel Auto Search feature

When this item is set to 255 (default), once every 24 hours, the STB attempts to find an active Pro:Centric server.

- If connected to an IP network, the STB will first check for a “procentric.local” DNS entry. If the Pro:Centric server IP address is obtained from a DNS server, the DATA CHANNEL value will be changed from 255 to 253, which designates an IP data channel.

Note: The automated IP configuration feature requires a “procentric.local” DNS entry, which enables the Auto Search to obtain the Pro:Centric server’s IP address. This feature also expects the Pro:Centric server’s port number to be set to “80.”

- If an IP data channel is not found, the STB searches for an RF data channel. The STB will initiate a search of 10 predefined RF channels (10, 20, 30, ... 100) and then, if necessary, perform a complete search of the RF channels (1 to 135). If the Pro:Centric RF channel is found, the DATA CHANNEL value will be changed from 255 to match the server’s RF channel number.

The time at which the Auto Search occurs depends on the setting of item 121 UPDATE TIME HR. See item 121 description for further information.

Note: Pro:Centric updates are downloaded from the Pro:Centric server to the STB when the STB/display panel is turned OFF. While Pro:Centric updates are in progress, it is not possible to turn ON the STB/display.

Note: The Data Channel value also is automatically set to 253 if Media Type is set to “IP” either in the Solution Settings / EZ-Manager Wizard (see “Solution Settings / EZ-Manager Wizard” on pages 32 to 44) or in the STB’s IP Environment / Pro:Centric Menu (see “Pro:Centric Setup” on pages 87 to 90) or if Installer

Menu item #119 Data Channel is set to “IP Address” or “IP Domain Name” in the Cloud Configuration Tool, which is typically used to configure STB CPUs for FTG Mode operation. It is not possible to change the value to “253” directly in the Installer Menu.

Note: The Data Channel value is automatically set to 254 if Server Type is set to “Pro:Centric Cloud” either in the Solution Settings / EZ-Manager Wizard (see “Solution Settings / EZ-Manager Wizard” on pages 32 to 44) or in the IP Environment / Pro:Centric Menu (see “Pro:Centric Setup” on pages 87 to 90) on the TV or if Installer Menu item #119 Data Channel is set to “P:C Cloud” in the Cloud Configuration Tool. It is not possible to change the value to “254” directly in the Installer Menu.

121 - UPDATE TIME HR

Based on the settings of this item and item 122 UPDATE TIME MN, the Wake For Update feature wakes the STB once daily to check for and, if applicable, download updates from the Pro:Centric server.

Set the Wake For Update hour from 0 to 23. This item uses the 24-hour clock format. The default value (128) is displayed as “DFT,” which means Default Time. Directly entering “128” resets the default value (Default Time) for this item. See additional information below.

Under standard STB/display panel OFF/ON operating conditions (i.e., item 002 AC ON is set to 0), a Wake For Update event occurs when the STB/display is OFF and causes the STB to temporarily turn ON, perform the update cycle, and then turn back OFF, all while the display remains OFF. If item 002 AC ON is set to 2, 3, 18, or 19 for Instant ON, then the STB is always ON and Wake For Update occurs when the display is OFF. The Wake for Update event causes the STB to reboot in order to perform the update cycle and then return to its ON state with the display panel OFF. See also description for item 002.

Random Distribution of Update Time: If this item is set to 128 (Default Time), the time at which a Data Channel Auto Search (item 119 set to 255) and/or an Instant ON update (item 002 set to 2, 3, 18, or 19) occurs is determined as follows: Each STB initiates the search and/or checks for updates during the 2 AM hour (if the STB clock is set) or after two hours of elapsed time from when AC power was applied (if the STB clock is not set). Also, in this case, a fixed update time minute from 0 to 59 that has been assigned to each STB is used. (The intention of this feature is to prevent all of the installed STBs from performing updates at the same time; however, note that in installations that have a large quantity of STBs with this feature, there will be some STBs that have the same update minute assignments.) The update time for the STB is displayed at the right of this item in the Installer Menu, for example:

121 UPDATE TIME HR DFT [02:34]

* PCS150R and later Pro:Centric servers do not support HRC or IRC cable channel frequencies.

If the display is ON when a Wake For Update is to occur, the update will take place the next time the display is turned OFF.



Caution: UPDATE TIME HR should NEVER be set to 255 (PREVENT). This setting is intended for factory use only.

Note: Brackets are only shown around the DFT (Default Time) setting. Any other time value for this item will not be shown with brackets.

Note: This item is not available in the Installer Menu when item 119 DATA CHANNEL is set to 0, except when item 002 AC ON is set to 2, 3, 18, or 19 for Instant ON. In addition, this item is not available in the Installer Menu when item 002 AC ON is set to 1, unless item 098 is not set to 0.

Note: The STB clock must be set in order for a Wake For Update event to occur at the precise time of day in accordance with item 121 and item 122 settings.

122 - UPDATE TIME MN

Set the Wake For Update minute from 0 to 59. If item 121 is NOT set to 128 and you wish to invoke the "random" minute assignment on the STB, set this item to 255. See also description for item 121 UPDATE TIME HR above.

Note: This item is not available in the Installer Menu unless item 121 UPDATE TIME HR is set from 0 to 23.

Note: The STB clock must be set in order for a Wake For Update event to occur at the precise time of day in accordance with item 121 and item 122 settings.

Custom Master STB Setup

This section describes how to create a customized Master STB Setup for cloning purposes when the STB is in Pass-through Mode. All cloning (export and import) processes on the STB are performed via USB memory device / “.tlx” file. The Master STB Setup may be exported to a Clone (.tlx) file, which can then be used (i.e., imported) to configure either STBs that are to remain in Pass-through Mode or STBs that are to be configured for FTG Mode.

Cloning requirements and procedures are described in detail on pages 67 to 73.

Note: You can also use the Cloud Configuration Tool to create an FTG Configuration (.tlx) file for FTG Mode configuration/cloning purposes, if desired (see pages 74 to 77). However, it is not possible to customize STB setup menu settings in the Cloud Configuration Tool. If you wish to include customized STB setup menu settings in the STB configuration, in addition to the channel lineup and Installer Menu settings, perform the Master STB Setup procedure to create a Clone (.tlx) configuration file.

Before You Begin

- It is recommended that you disconnect all STB Aux inputs if you intend to run Channel Tuning (Channel Search). Under certain conditions, Channel Tuning is disabled if there is an Aux input active.
- A Clone (.tlx) file comprises Installer Menu settings, IP Environment Menu settings (with the exception of unique STB attributes and settings), and all STB sources’ (analog, digital, AV, HDMI, etc.) clonable setup menu settings. See also “Clonable STB Setup Menu Features” list below.
- If the “.tlx” file (either a Clone or FTG Configuration file) to be imported on the Target STB(s) contains an FTG Channel Map, the Target STB(s) will be configured for FTG Mode, though as part of the import process, depending on the types of channels included in the Channel Map, you may have the option to select either logical or physical channel tuning. If you would like the Target STB(s) to remain in Pass-through Mode, the “.tlx” file should not include an FTG Channel Map.

Clonable STB Setup Menu Features

Sound Additional Settings – AV Sync Adjustment	General Language Time – Clock Mode (Auto/Manual) – Time Zone Additional Settings – Pointer Options – Menu Transparency – Power Saving Mode (No Signal Power Off)	Accessibility Audio Guidance TV Power Sound High Contrast Closed Caption – Analog Mode – Digital Mode
Channels Channel Tuning Channel Manager Channel Label		

Note: Some menu options vary between analog and digital channels and Aux inputs.

Note: The Quick Settings Menu is initially displayed when you press **MENU** on the Installer Remote. Select the **All Settings**  menu icon to access the advanced STB setup menus. Several advanced settings are duplicated in the Quick Settings Menu.

Custom Master STB Setup Procedure

1. Turn ON the STB/display panel.

The next step depends on whether the First Use Wizard appears on the screen when you turn ON the STB/display:

- If the wizard is displayed, the STB is in the required factory default state. Exit the wizard, and then continue with step 2.
- If the wizard is not displayed, restore the STB to a factory default condition before continuing with this procedure. See Reference section, “Restoring Factory Defaults on the STB(s),” as necessary, for further information.

2. Set Installer Menu items.

This step provides specific instruction only on the Installer Menu items that should be set on a Master STB. Refer to pages 50 to 63 for detailed information on all Installer Menu items.

- Use the Installer Remote to access the Installer Menu (see “Accessing the Installer Menu” on page 50 for further information).
- Set Installer Menu item **003 BAND/AFC**, as appropriate.
 - Broadcast: Set to 0.
 - Cable: Set to 1 (default).
 - HRC: Set to 2.
 - IRC: Set to 3.
- Set any other Installer Menu items as necessary, per installation/property requirements. For example, set the panel display type (if applicable), enable/disable Aux inputs, set a Start Channel, etc.
- After you have adjusted all Installer Menu item settings as required, and if you do not need to configure any IP Environment settings (see note below), press **OK** once on the Installer Remote to save your changes; then, press **OK** again to exit the menu.

Note: If you intend to configure settings in the IP Environment Menu, which is accessible from the Installer Menu, you can proceed directly to step 3. All Installer Menu settings will be saved automatically when you access the IP Environment Menu.

3. Configure IP Environment settings.

Note: You cannot return directly to the Installer Menu from the IP Environment Menu; thus, you may wish to set all Installer Menu items as needed before you access the IP Environment Menu. Otherwise, you will need to reaccess the Installer Menu to set additional items.

Navigate to Installer Menu item 119 DATA CHANNEL, and press **2-5-3 + MENU** to launch the IP Environment Menu. Then, complete network configuration as required. In particular, if you intend to use the Wi-Fi Zoning feature, you must configure the wireless network connection as part of the Master STB Setup. See “IP Environment Setup” on pages 81 to 98 for further information.

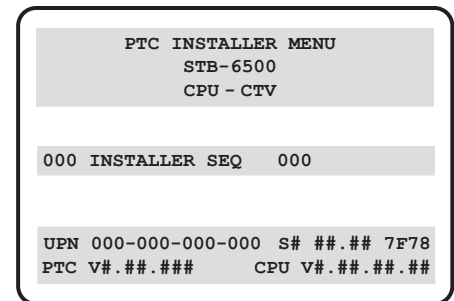

Typical Installer Menu

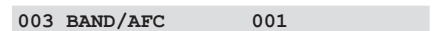

Adjust the value for this Installer Menu item, as required.

(Continued on next page)

Custom Master STB Setup (Cont.)

(Continued from previous page)

4. Set up STB/display panel features.

On-screen setup menus control the features of the STB/display. Press **MENU** on the Installer Remote, and select the **All Settings** menu icon from the Quick Settings Menu to access the advanced STB setup menus. Then, set Picture, Sound, Channels, etc. options to the desired configurations. See “Clonable STB Setup Menu Features” list on page 64 and also notes below.

Note: If you intend to use the Zoning feature(s) on this STB, make sure to assign the appropriate STB Zone # and/or Wi-Fi Zone # at this time as described in Reference section, “Using the STB’s Zoning Features.”

Note: If desired and if appropriate, you can run Channel Tuning (see step 5) prior to completing this step.

5. (Optional) Run Channel Tuning.

If you are creating a Master STB Setup for cloning purposes and you want the Target STB(s) to remain in Pass-through Mode or Application Tuning Mode, as applicable, do NOT run Channel Tuning. If you export a Master STB Setup that includes an auto-tuned/edited channel lineup, thereby creating a Clone (.tlx) file with an FTG Channel Map, and then import the Clone file to a Target STB, this will put the Target STB in FTG Mode.

Note: When you import a Clone/Configuration (.tlx) file that contains an FTG Channel Map on a Target STB (for FTG Mode configuration), depending on the types of channels included in the Channel Map, you may have the option to select either logical or physical channel tuning. For either selection, the channel sequence will be based on the order in which the channels appear in the FTG Channel Map. You can view and/or edit the channel sequence in the Cloud Configuration Tool, as required.

- a) Use the Installer Remote to access the Channels Menu. Then, select **Channel Tuning** and follow the on-screen instructions to search for all available digital and analog channels.
- b) Use the **Channel Manager** option in the Channels Menu to edit the channel lineup, as necessary. Add/delete channels per your system requirements.

6. Verify the STB/display panel setup.

Make sure the STB/display features are set per your requirements. Also, if applicable, verify that the channel lineup is correct.

The Master STB Setup is now ready to be saved (exported) to a USB memory device. See “Cloning Procedures” on pages 67 to 73.

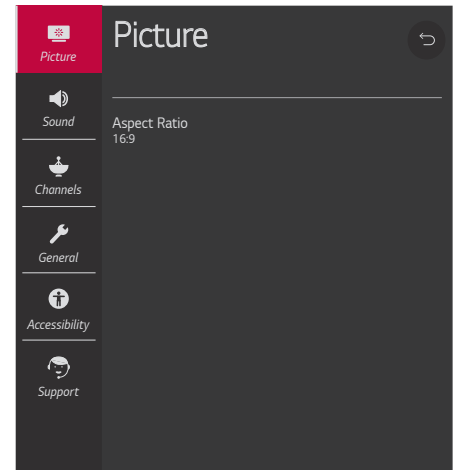

Use the STB setup menus to set the display features to the desired configuration for the end user. This example illustrates the advanced STB setup menus.

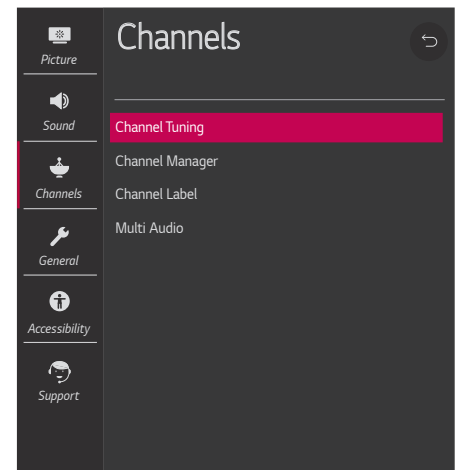

(Optional) Use Channels Menu options to run Channel Tuning and edit the channel lineup.

Cloning typically refers to the process of using a Master STB Setup to configure a Target STB. This section describes how to save (export) a Master STB Setup and then transfer (import) it to a Target STB using a USB memory device / Clone (.tlx) file.

You can also create an FTG Configuration (.tlx) file using the Cloud Configuration Tool and then use the Import Clone File procedure to transfer the configuration to Target STBs. Refer to “Creating an FTG Configuration File” on pages 74 to 77, as necessary.

Exporting a Clone File

This section describes how to use the STB Manager “Export Clone File” option to export Master STB Setup configuration to a USB memory device / Clone (.tlx) file.

Before You Begin

- Ensure the USB device has been formatted with FAT format.
- If applicable, complete the Custom Master STB Setup procedure (see pages 64 to 66).
- If you would like the Target STB(s) to remain in Pass-through Mode or Application Tuning Mode, as applicable, after the Clone file is imported, ensure the Master STB does not have an auto-tuned/edited channel lineup; otherwise, importing the exported file will result in the Target STB(s) being configured for FTG Mode.
- If you intend to use the STB Zoning feature(s), make sure to assign the appropriate STB Zone # and/or Wi-Fi Zone # as described in Reference section, “Using the STB’s Zoning Features,” BEFORE performing the procedure below. Also, for Wi-Fi Zoning in particular, the STB’s wireless network connection settings should be configured in the IP Environment Menu before exporting is initiated.
- It is not possible to clone a Master STB’s clock. Either set a Target STB’s clock manually, or use the Auto Clock setting in the STB setup menus.



Caution: Do not unplug the STB power cord or remove the USB memory device while exporting is in progress, as doing so may cause the STB to malfunction or harm the USB device, respectively.

Export Clone File Procedure

1. Ensure the Master STB/display panel is set up completely and turned ON.
2. Insert the USB memory device into either of the USB ports on the Master STB.
3. Press **MENU** on the Installer Remote to display the STB setup menus (STB is in Pass-through Mode) or the Function Menu (STB is already in FTG Mode).
4. (STB in Pass-through Mode only) From the Quick Settings Menu displayed at the left of the screen, select the **All Settings**  menu icon and press **OK** to access the advanced STB setup menus.
5. Use the arrow navigation keys to select/highlight either the **General** menu icon from the STB setup menus or the **Safety** menu icon from the Function Menu. Then, press the number “7” key a total of seven times to display the STB Manager.

(Continued on next page)

Cloning Procedures (Cont.)

(Continued from previous page)

Note: If a password prompt is displayed (i.e., STB Manager Password Protection is enabled in the IP Environment / General Menu), key in the STB Manager password and press **OK**.

Note: Ez Download is always selected by default when you initially access the STB Manager. Also, note that Diagnostics is for service use only.

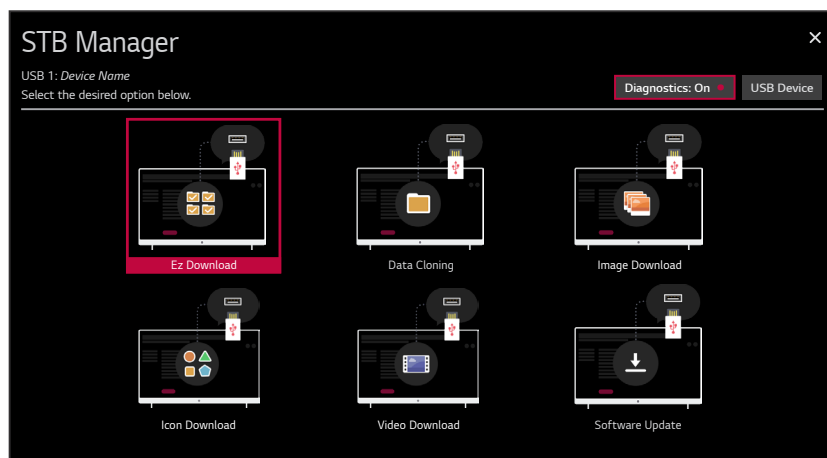

6. If more than one USB memory device is currently connected to the STB, be sure to select the USB device on which you wish to save the Clone file. If necessary, use the arrow keys on the Installer Remote to select/highlight the USB Device button in the top right corner of the screen and press **OK**. Then, use the Up/Down arrow keys to select the appropriate USB device from the pop-up list of USB devices.

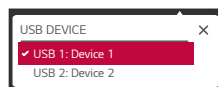

7. Use the arrow keys to select **Data Cloning**, and then press **OK**.
8. With the Data Cloning screen on display, use the Up/Down arrow keys to select **Export Clone File**, and then press **OK**.

Clone filename parameters will be displayed on the screen (see example on following page).

9. Modify the filename, as required. While the STB model element of the filename may not be changed, you can differentiate this Clone file from other STB-6500 Clone files by changing the numeric assignment appended to the end of the filename. Select/highlight the filename, and then use the Up/Down arrow keys on the Installer Remote to scroll through numeric assignments until the desired number is shown.

(Continued on next page)

(Continued from previous page)

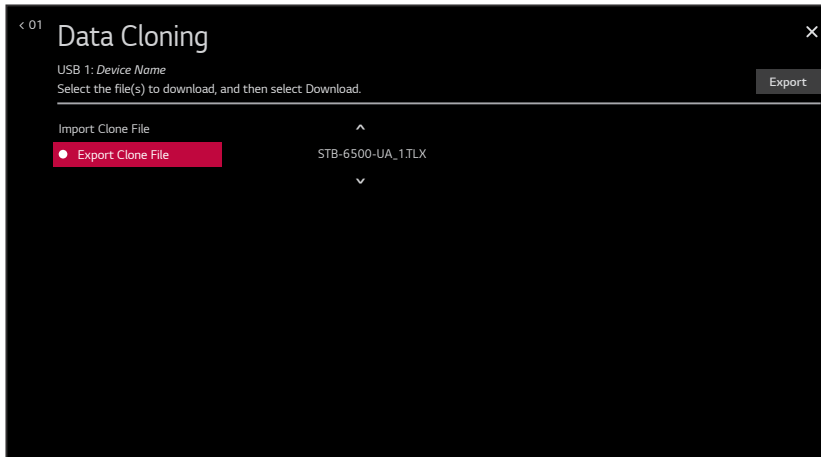

10. When you are ready to continue, i.e., when you have selected the desired filename, press **OK** on the Installer Remote to select/activate the **Export** button at the bottom of the screen, and then press **OK** on the Installer Remote once more to export the file.

Export progress will be displayed on the screen. This process may take a few minutes. Do NOT remove the USB device while exporting is in progress. When the export process is complete, an "Export Clone File is completed" pop-up message will be displayed on the screen.

11. Press **OK** to return to STB Manager / Data Cloning screen. To return to program viewing, select the **X** button at the top right corner of the screen.
12. Remove the USB memory device from the Master STB.

 **Note: If the Master STB has a channel lineup, during the export process, logical channel numbers are automatically assigned in ascending order, starting with 0 (zero), to the physical RF channels of the STB channel lineup to create an FTG Channel Map. See also note below.**

 **Note: If the exported Clone file is to be used for FTG Mode configuration (i.e., it contains an FTG Channel Map), it is highly recommended that you open the file in the Cloud Configuration Tool—BEFORE transferring (importing) the file to any Target STBs—to verify FTG Channel Map and FTG Installer Menu settings. This will also enable you to confirm channels and add channel attributes, labels, etc.**

Importing a Clone File

This section describes how to transfer (import) a Clone or Configuration (.tlx) file from a USB memory device to an STB using the STB Manager "Import Clone File" option. The ".tlx" file may be created either from a Master STB Setup that was saved (exported) from a Master STB or in the Cloud Configuration Tool.

Cloning Procedures (Cont.)

Before You Begin

- Ensure the USB device has been formatted with FAT format.
- Avoid using special characters, such as ?, &, @, etc., in the Clone/Configuration (.tlx) filename.
- If you have initiated the Solution Settings / EZ-Manager Wizard, you can use the wizard's "USB Configuration" option to access the STB Manager and complete the import procedure (see "STB Configuration Options" and/or "USB Configuration" on pages 32 and 43, respectively, as necessary).
- You may also use the Ez Download utility to import the Clone/Configuration (.tlx) file. See "Ez Download Utility" on pages 45 to 49 for further information.
- If the Target STB is currently in Pass-through Mode and you intend to use the STB's Zoning feature(s)—i.e., the Clone/Configuration (.tlx) file you are importing contains an FTG Channel Map and/or FTG profile(s) with STB Zone and/or Wi-Fi Zone assignments—make sure to set the appropriate STB Zone # and/or Wi-Fi Zone # in the STB when directed to do so in the procedure below. See Reference section, "Using the STB's Zoning Features," for further information.
- If you would like the Target STB(s) to remain in Pass-through Mode or Application Tuning Mode, as applicable, after the Clone/Configuration (.tlx) file is imported, ensure the ".tlx" file does not contain an FTG Channel Map; otherwise, the import procedure will result in the Target STB(s) being configured for FTG Mode.
- If a Clone (.tlx) file (exported Master STB Setup) contains an FTG Channel Map, the physical RF channels in the FTG Channel Map have been assigned logical channel numbers (see "Exporting a Clone File" above). When you import the Clone file with the FTG Channel Map to the Target STB(s), you will have the option to select either logical or physical channel tuning. Even if you select physical channel tuning, the (list of) physical RF channels in the FTG Channel Map will remain in logical order.
- If an FTG Configuration (.tlx) file (created in the Cloud Configuration Tool) contains an FTG Channel Map, each logical channel number in the FTG Channel Map has been assigned a physical RF channel, an IP channel, or an Aux input (the latter designated by 130-0 through 137-0—see also Reference section, "STB Aux Input Configuration").

Note: If the FTG Channel Map includes RF channels and Aux inputs *only*, when you import the FTG Configuration file on the Target STB(s) you will have the option to select either logical or physical channel tuning. If you select physical channel tuning, the physical RF channels and Aux inputs in the FTG Channel Map will remain in logical order. Physical channel tuning is not available when the FTG Channel Map includes IP channels.

- If the Clone/Configuration (.tlx) file was edited/created in the Cloud Configuration Tool, it may contain multiple zoned FTG Installer Menu profiles for different STB/TV models. Make sure it includes the appropriate Installer Menu profile(s) for the Target STB(s) before performing the procedure below.



Caution: Do not unplug the STB power cord or remove the USB memory device while importing is in progress, as doing so may cause the STB to malfunction or harm the USB device, respectively.

Import Clone File Procedure

1. Turn ON the Target STB/display panel.
2. The next step depends on whether the First Use Wizard appears on the screen when you turn ON the STB/display:
 - If the wizard is displayed, you can complete the import procedure via the Solution Settings / EZ-Manager Wizard, as indicated above (see “Before You Begin”). However, to continue with this procedure and access the “Import Clone File” option from the STB menus, exit the First Use Wizard. Then, continue with step 3.
 - If the wizard is not displayed, go directly to step 3.
3. If applicable (see also “Before You Begin” above), make sure to assign the appropriate Zone designation(s) in the Target STB at this time.



Note: In order for the proper STB Zone and/or Wi-Fi Zone profile data to be applied, the appropriate STB Zone # and/or Wi-Fi Zone # must be set in the Target STB BEFORE importing is initiated.

4. Insert the USB memory device with the Clone/Configuration (.tlx) file into either of the USB ports on the Target STB.
5. Press **MENU** on the Installer Remote to display the STB setup menus (STB is in Pass-through Mode) or the Function Menu (STB is already in FTG Mode).
6. (STB in Pass-through Mode only) From the Quick Settings Menu displayed at the left of the screen, select the **All Settings**  menu icon and press **OK** to access the advanced STB setup menus.
7. Use the arrow navigation keys to select/highlight either the **General** menu icon from the STB setup menus or the **Safety** menu icon from the Function Menu. Then, press the number “7” key a total of seven times to display the STB Manager.

Note: If a password prompt is displayed (i.e., STB Manager Password Protection is enabled in the IP Environment / General Menu), key in the STB Manager password and press **OK**.

Note: Ez Download is always selected by default when you initially access the STB Manager. Also note that Diagnostics is for service use only.

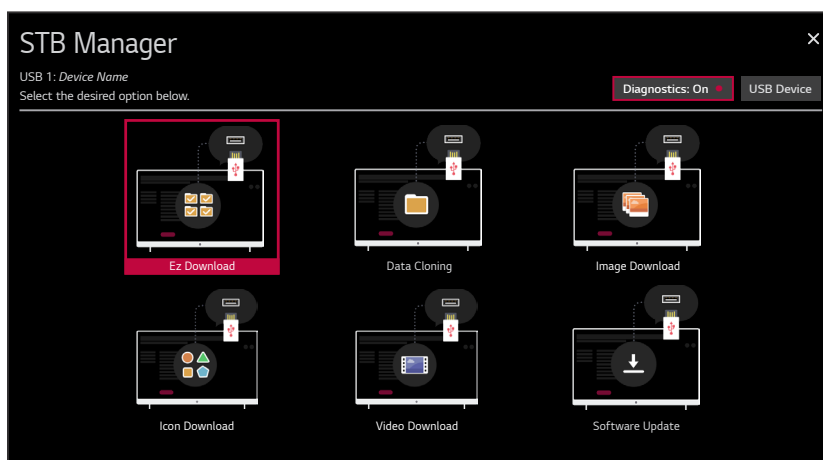

(Continued on next page)

Cloning Procedures (Cont.)

(Continued from previous page)

- If more than one USB memory device is currently connected to the STB, be sure to select the USB device that contains the “.tlx” file you wish to use. If necessary, use the arrow keys on the Installer Remote to select/highlight the USB Device button in the top right corner of the screen and press OK. Then, use the Up/Down arrow keys to select the appropriate USB device from the pop-up list of USB devices displayed at the top of the screen.

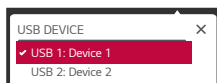

- Use the arrow keys to select **Data Cloning**, and then press **OK**.

When the Data Cloning screen is initially displayed, the “Import Clone File” option is selected by default, and a list of the “.tlx” files stored in the root folder of the USB memory device is displayed on the screen.

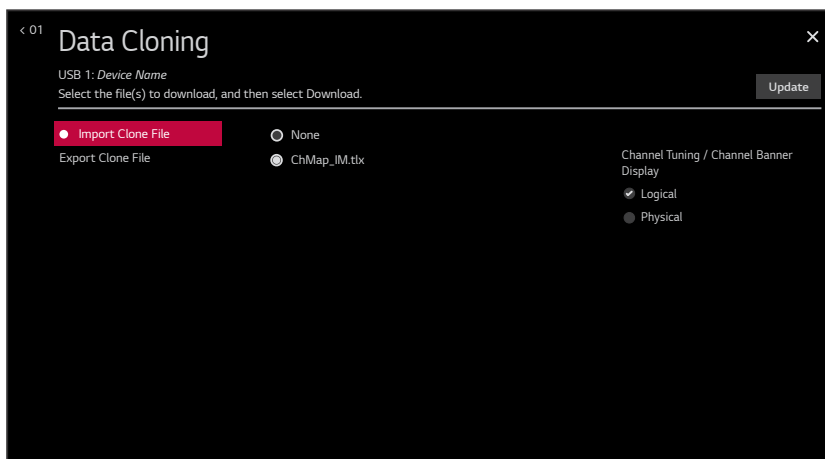

- Use the arrow keys on the Installer Remote to select/highlight the “.tlx” file to import, and then press **OK**.

Note: Filenames of exported Clone files are comprised of the STB model and a numeric element, for example, STB-6500-UA_1.TLX.

- If the Clone/Configuration (.tlx) file includes an FTG Channel Map with RF channels and Aux inputs *only*, you can choose the format for the channel tuning/banner display. Use the arrow keys to select the desired Channel Tuning / Channel Banner Display option—either Logical or Physical—at the right side of the screen. A checkmark will appear at the left of the selected option. Logical tuning is selected by default.

Note: If an FTG Channel Map includes IP channels, only logical tuning is available. Also, if the “.tlx” file does not include an FTG Channel Map, the message, “No Channel Map in Clone file,” will be displayed at the right of the screen.

(Continued on next page)

(Continued from previous page)

12. When you are ready to continue, select **Update** on the screen and then press **OK** on the Installer Remote.

Import progress will be displayed on the screen. This process may take a few minutes. Do NOT remove the USB device while importing is in progress. When the import process is complete, an “Import Clone File is completed” pop-up message will briefly be displayed on the screen, and then, the STB will reboot.

13. Remove the USB memory device from the Target STB, and verify that the appropriate configuration is now resident on the Target STB.

Note: If the Target STB was previously in Pass-through Mode, and the Clone/Configuration (.tlx) file that was imported contained an FTG Channel Map, the Target STB CPU is now in FTG Mode. Upon restart (and, if applicable, confirmation of new video output resolution—see note below), the STB tunes according to the Start Channel setting in the Installer Menu. If a Start Channel is specified, the STB will tune to that channel, though, in the case of FTG Mode configuration, a channel banner will only be displayed if the Start Channel is included in the FTG Channel Map (depending on your selection in step 11, the channel banner will display either the Start Channel’s logical channel number or physical RF channel number). Otherwise, the STB will either return to the last channel tuned (STB in Pass-through Mode) or tune to the first channel in the FTG Channel Map (STB in FTG Mode). If the latter, remember that the channels in the FTG Channel Map are always arranged in logical order, regardless of your selection in step 11.

Note: If you updated the STB configuration with a Clone/Configuration (.tlx) file that included a change to Installer Menu item 105 VID OUT FORMAT, when the reboot is complete, you will be prompted to confirm the new video output resolution. See item 105 description on page 60 for further information.

Cloud Configuration Tool Overview

This section provides an overview of LG's Cloud Configuration Tool web application, which is used for FTG Mode configuration. For best results, it is recommended that you access the Cloud Configuration Tool using one of the following web browsers: Google Chrome™ 51 or later or Mozilla Firefox® 47 or later.

Creating an FTG Configuration File

The subsections below briefly describe how to use the Cloud Configuration Tool to create an FTG Configuration (.tx) file (i.e., for FTG Mode configuration) that can be saved to a USB memory device. The Cloud Configuration Tool provides options both for advanced and new users. If you are not familiar with the steps to create an FTG Configuration file, you may choose a wizard setup that will guide you through the process of creating a new file. Refer to the **Cloud Configuration Tool User Guide** for further information. See also sample screens on pages 78 to 80 of this document.

Note: There is also an option to save (export) configuration from an STB, which may be desirable or required if you want to save customized STB setup menu settings to the FTG Configuration file and/or if you do not know the RF channels at the site. See “Exporting a Clone File” on pages 67 to 69 for further information.

Access the Cloud Configuration Tool and Select a Setup Option

1. Launch a web browser, and navigate to the following URL: **cct.procentric.tv**.
2. On the Welcome web page, make sure **North America** (default) is selected in the Select Your Region field, and then click on the **SELECT** button at the right of the field.

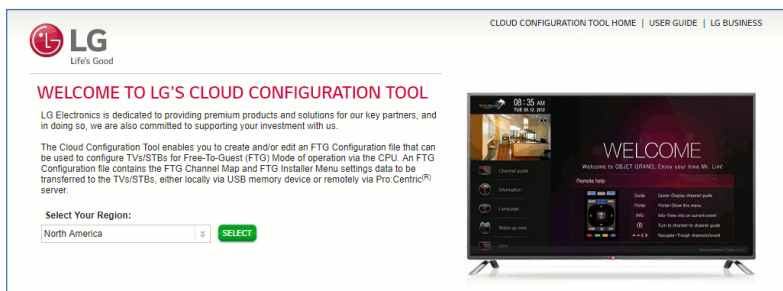

3. Once you select your region, you can choose the desired setup option, depending on your familiarity with the utilities and/or your file requirements:

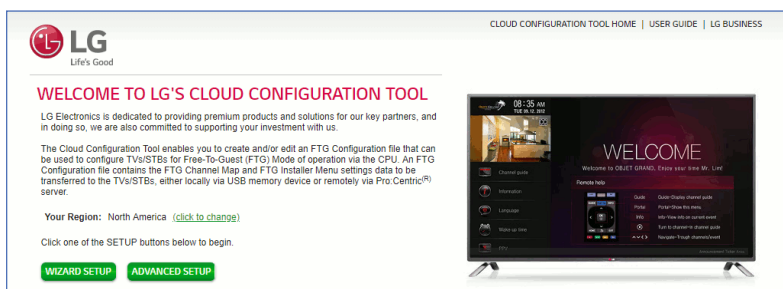

(Continued on next page)

Cloud Configuration Tool Overview (Cont.)

(Continued from previous page)

- If you are creating an FTG Configuration file from scratch and this is your first time using the Cloud Configuration Tool, you may wish to select the Wizard Setup, which will guide you through the essential steps of creating the file—building the Channel Map and/or the Installer Menu profile(s). To initiate the Wizard Setup, click on the **WIZARD SETUP** button.

On the next wizard page you will be prompted to indicate whether you would like to create an FTG Channel Map. Note that an FTG Channel Map is required for FTG Mode operation. Once you complete (or bypass) Channel Map activities and proceed to the next step, you will be prompted to indicate whether you would like to create an Installer Menu profile. The final wizard step enables you to review a summary of the FTG Configuration (.tlx) file contents and then save (export) the file to your PC.

- To view and/or base a new FTG Configuration file on an existing FTG Configuration (.tlx) file, or if you do not require wizard guidance to complete your activities, click on the **ADVANCED SETUP** button.

The File Manager web page will be displayed, and you have a number of options.

The following procedure provides an overview of the Advanced Setup. Refer to the **Cloud Configuration Tool User Guide** for further information on both the Wizard Setup and the Advanced Setup.

Advanced Setup Overview

1. When you select **ADVANCED SETUP** from the Welcome page (see “Access the Cloud Configuration Tool and Select a Setup Option” above), the File Manager page is displayed (see example on page 78).
2. (Optional) If desired/appropriate, you may view and/or base the new FTG Configuration file on an existing FTG Configuration (.tlx) file:
 - Click on the **BROWSE** button at the right of the Find File to Upload field, and select/double-click on the desired “.tlx” file. Then, click on the **UPLOAD** button below the Find File to Upload field.

Once the file is successfully uploaded, the Find File to Upload field is replaced with a Loaded From File summary of the file’s contents, including a Channel Map Summary, Installer Menu Summary, and Setup Menu Summary.

 - Double-click on each item in the Loaded From File summary at the left of the page that you would like to copy to the FTG Configuration List at the right of the page. As you move your mouse over the contents of a summary field, the field will be highlighted in blue, and **>>>** arrows at the right of the field will indicate that the data may be copied to the FTG Configuration List.
 - Edit the configuration of the items in the FTG Configuration List as well as the FTG Configuration List itself, as necessary, to create a new file.

Note: While Setup Menu profiles can be included in the new FTG Configuration file (i.e., the profile[s] can be copied to the FTG Configuration List), Setup Menu profiles are not available for editing. However, on the File Manager page, you may change the Zone assignment for a Setup Menu profile, as required, for those models on which the STB Zoning feature is supported.

(Continued on next page)

Cloud Configuration Tool Overview (Cont.)

(Continued from previous page)

Note: If desired, you can click on the **UPLOAD NEW FILE** button below the list of Loaded From File items to select a different existing FTG Configuration file. If you want to add Installer Menu and/or Setup Menu profiles from more than one existing file to the new FTG Configuration file, make sure to transfer the appropriate items from the currently uploaded file to the FTG Configuration List before uploading a different file.

3. If you need to edit the FTG Channel Map from an existing file (see previous step) or create a new FTG Channel Map, click on **CHANNEL MAP** in the menu options bar at the top left of the page to access the Channel Map web page (see example on page 79), and edit/create the FTG Channel Map. Up to 600 logical channels—combined total of both RF and IP mapped channels—can be defined in the FTG Channel Map.
4. (Optional) To load default FTG Installer Menu settings by model, click on **INSTALLER MENU** in the menu options bar at the top left of the page to access the Installer Menu web page (see example on page 80), select the desired model/chassis ID and the desired Zone, and then click on the **CREATE PROFILE** button to create a new profile.

The new model profile will be added to the Installer Menu Profile List at the top right of the page, and the Installer Menu items for the selected model will now be displayed on the lower half of the page. The Summary tab shows the features that are available for configuration. Click on any Installer Menu item in the Summary tab or a category (User, Tuning, Audio, etc.) tab to view and/or edit its parameters, as required.

Note: Unless you select a different Zone assignment when you create the new profile, the default Zone 0 is assigned automatically. See Reference section, “Using the STB’s Zoning Features,” for further information on the STB Zoning feature and setting the STB Zone # in the STB(s).

5. Click on **FILE MANAGER** in the menu options bar at the top left of the page to return to the File Manager web page. The FTG Configuration List will now be populated with summaries of the FTG Channel Map, FTG Installer Menu profile(s), and, if applicable, Setup Menu profile(s) you created or added in the previous steps. Review and edit the FTG Configuration List, as necessary.

Note: If you need to edit the Channel Map or an Installer Menu profile, double-click on the desired item to access the Channel Map page or the Installer Menu page, as applicable. When you return to the File Manager page, the FTG Configuration List is automatically updated with all Channel Map and Installer Menu changes. (Installer Menu and/or Setup Menu profile Zone assignments may be changed on the File Manager page.)

Note: To remove an individual item from the FTG Configuration List, click on the **✗** at the right of the applicable item. At the prompt for confirmation , either click **yes** to confirm and remove the item immediately, or click **no** to retain the item. To clear all current FTG Configuration List contents, click on the **CLEAR LIST** button at the bottom right of the FTG Configuration List.

6. Export the FTG Configuration List contents to an FTG Configuration (.tlx) file on the PC’s hard drive for later use:

(Continued on next page)

Cloud Configuration Tool Overview (Cont.)

(Continued from previous page)

- Type a brief descriptive name in the File Name field at the bottom of the FTG Configuration List (avoid using special characters, such as ?, &, @, etc.).
- Click on **EXPORT FILE**.
- In the Save As window (if applicable—see note below), select the desired location to which to export the file (you can also edit the file name here, if necessary), and click **Save**.

Note: Depending on the browser you are using and its current settings, files may automatically be saved to the “Downloads” or another designated folder on your PC. If you want to be able to select the folder in which to save the FTG Configuration file, check your browser settings.

7. Transfer the FTG Configuration (.tlx) file to a USB memory device, and proceed to “Importing a Clone File” on pages 69 to 73 to transfer the FTG Configuration file to an STB-6500.

Cloud Configuration Tool Overview (Cont.)

File Manager Web Page Overview

The File Manager page (displayed after you select **ADVANCED SETUP** from the Welcome page) enables you to compile, modify, and save (export) FTG Configuration (.tlx) files. The following example provides an overview reference of the functions available on the File Manager page.

Data contained in uploaded FTG Configuration (.tlx) file. Users may choose to copy some or all of this data to the FTG Configuration List.

Data to be saved in the FTG Configuration (.tlx) file. This data may include contents transferred from an uploaded file and/or Channel Map/ Installer Menu contents created or modified in the Cloud Configuration Tool.

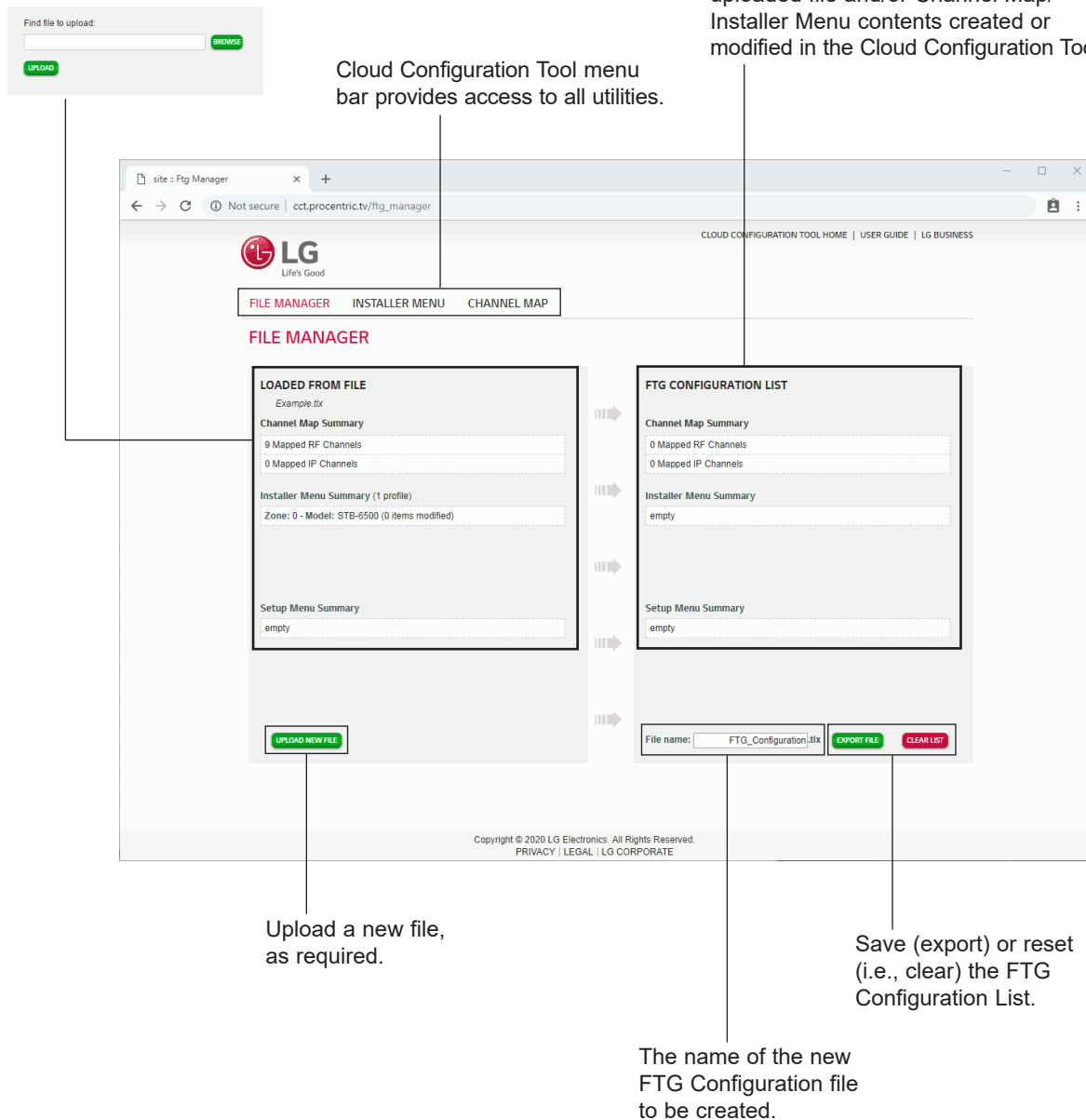

Cloud Configuration Tool Overview (Cont.)

Channel Map Web Page Overview

On the Channel Map page, you can create, view, and edit a Logical Channel Map.

Search for existing channels or clear the FTG Channel Map.

(Advanced Setup only) Cloud Configuration Tool menu bar provides access to all utilities.

Click the appropriate button to add a new RF or IP channel to the FTG Channel Map.

(Wizard Setup only) Proceed to next step.

The screenshot shows the 'CHANNEL MAP' page in a web browser. At the top, there is a navigation bar with 'FILE MANAGER', 'INSTALLER MENU', and 'CHANNEL MAP'. Below this is a search bar labeled 'CHANNEL MAP Search: (enter Logical or Label)' with a 'CLEAR CHANNEL MAP' button. To the right of the search bar are buttons for 'RF CHANNEL' and 'IP CHANNEL', and a 'NEXT STEP' button. The main content is a table with the following columns: Logical, Channel Logo, Label, RF IP Address, Major, Minor, PLP ID, IP Type, IP Port, Prog #, Source Address, Attribute, Restricted from Zones, and Actions. The table contains several rows, including CBS, NBC, CNN, ABC, PBS, History, Discovery, and a row for 'HDMI 1' with Logical ID 93. Each row has edit and delete icons in the Actions column.

Click the appropriate icon to either edit an existing Logical Channel's data (see below) or remove a channel from the FTG Channel Map.

This example shows how to define an Aux input in the FTG Channel Map. See also Reference section, "STB Aux Input Configuration."

Select a channel logo (select "No Logo" if applicable), and/or enter a custom channel label.

As applicable, assign the RF, Major, and Minor channel numbers and PLP ID or enter the IP Address, Type, IP Port, and Program # data for the channel.

Set Zone restriction(s) per channel. Zones you select will be listed in the Restricted from Zones column. See Reference section, "Using the STB's Zoning Features," for further information.

The form shows the following fields and options:

- Logical: Input field with '0' entered.
- Channel Logo: Dropdown menu with 'no logo' selected.
- Label: Input field with '17 Character Limit'.
- RF IP Address: Input field with '1'.
- Major: Input field with '1'.
- Minor: Input field with '0'.
- PLP ID: Input field with '0'.
- IP Type: Input field with 'ATSC 3.0'.
- Attribute: Radio buttons for 'Encrypted' (checked), 'OSD' (checked), and 'Blank Video'.
- Restricted from Zones: Checkboxes for Zone 1 through Zone 8.
- Actions: 'SAVE' and 'CANCEL' buttons.

Enter a logical channel number.

Set channel attributes. Check/select Encrypted, OSD, or Blank Video.

After adding a new channel or editing an existing channel, save or cancel the changes.

Cloud Configuration Tool Overview (Cont.)

Installer Menu Web Page Overview

(Advanced Setup only) Cloud Configuration Tool menu bar provides access to all utilities.

Load default Installer Menu for selected model. Assign Zone as applicable. Once you click on CREATE PROFILE, this Installer Menu profile will be listed under the Installer Menu Profile List, and Installer Menu items will be displayed on the lower half of the page.

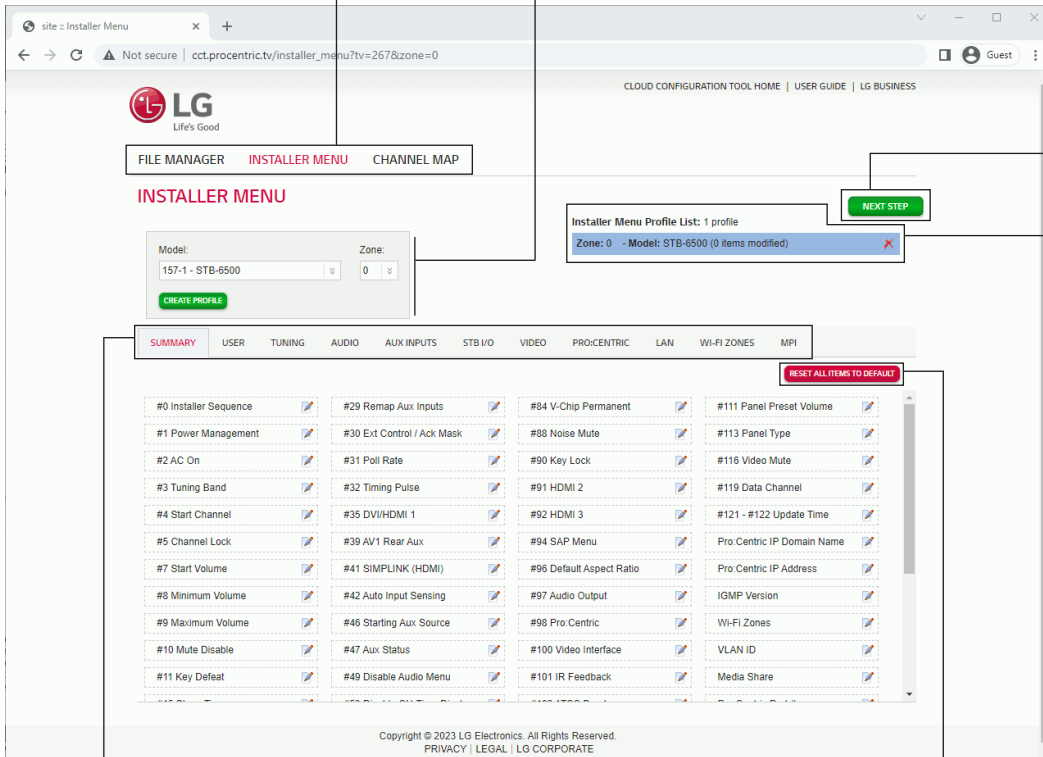

(Wizard Setup only) Proceed to next step.

Installer Menu profiles to be included in the FTG Configuration (.tx) file. The currently active profile is highlighted.

Select tabs for categories of Installer Menu items to set up STB.

Reset default values for currently active configuration profile. A RESET button is also available within each category tab.

Note: The Pro:Centric tab enables you to set up Pro:Centric-specific parameters, the LAN tab enables you to set up a variety of LAN features, and the Wi-Fi Zones tab enables you to set up Wi-Fi Zones. Refer to the **Cloud Configuration Tool User Guide** for further information. Also, see Reference section, "Using the STB's Zoning Features," for additional information on Wi-Fi Zoning.

The IP Environment Menu enables you to set up the network features of the STB. If you intend to create a Master STB Setup for cloning purposes (see Master STB Setup procedure on pages 64 to 66), all IP Environment settings, with the exception of wired network (Ethernet) settings, LG Connect settings, Pro:Centric Cloud settings, General Menu settings, the STB name (editable in the Media Share Menu), and SoftAP settings, may be cloned.

Note: With the exception of network settings, Pro:Centric Cloud settings, and General Menu settings, the IP Environment settings are editable (with the Installer Remote) only if the STB is in Pass-through Mode and read-only when the STB is not in Pass-through Mode.

Accessing the IP Environment Menu

The IP Environment Menu is accessible from the First Use Wizard or from the Installer Menu. For information on accessing the IP Environment Menu from the First Use Wizard, see “First Use Wizard” on pages 25 to 26. The steps below describe how to access the IP Environment Menu from the Installer Menu.

Note: When you enter the IP Environment Menu, the Installer Menu is exited (all current settings are saved automatically upon exit). If you are also in the process of updating Installer Menu items, you may wish to set all items as needed before you access the IP Environment Menu. Otherwise, after exiting the IP Environment Menu, you will need to reaccess the Installer Menu to set additional items.

1. Use the Installer Remote to access the Installer Menu (see “Accessing the Installer Menu” on page 50 for further information).
2. Navigate to Installer Menu item 119 DATA CHANNEL, and press **2-5-3 + MENU** to launch the IP Environment Menu.

Use the Up/Down arrow keys on the Installer Remote to select the desired menu option and then press **OK**. Refer to the following sections for information on each of the IP Environment setup options.

When you have completed your IP Environment configuration as required, press **EXIT** or **↵** on the Installer Remote to exit the IP Environment Menu.

Network Configuration

This section describes each of the options available in the Network Menu (see example at right). Refer to the appropriate subsection(s) on the following pages.

 **Note: If you intend to use the Wi-Fi Zoning feature with cloning configuration, you must configure the wireless network connection as part of the Master STB Setup. See “Configuring a Wi-Fi Network Connection” on pages 83 to 84 for further information.**

Accessing the Network Menu

With the IP Environment Menu on display, use the arrow keys on the Installer Remote to select the **Network** menu option. Then, press **OK**.

Note: The STB’s MAC address is displayed at the top of the Network Menu screen and cannot be modified.

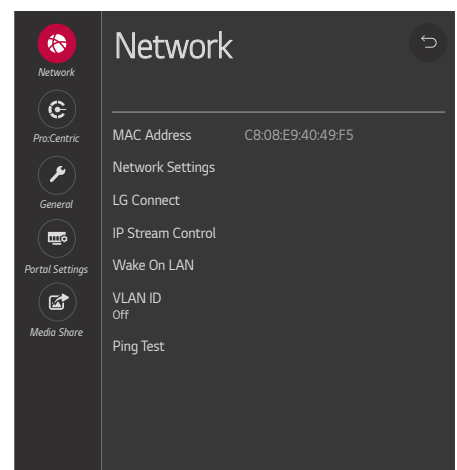

IP Environment Setup (Cont.)

Configuring a Wired Network Connection

Note: If desired, you can configure both wired and wireless connections to the Local Area Network (LAN). However, note that a wired connection is always prioritized over a wireless connection. That is, if an Ethernet cable is connected between the network and the STB's LAN port, the STB will default to the wired connection. If the Ethernet cable is removed, the STB will then attempt to establish the wireless connection. Whenever the Ethernet cable is reconnected to the STB's LAN port, the STB will re-establish the wired connection.

1. Connect the appropriate cable between the STB and the network.
2. With the Network Menu on display, use the arrow keys on the Installer Remote to select **Network Settings**. Then, press **OK**. A Network Settings screen (see example at right), with Wired and Wi-Fi Connection setup options, will be displayed.

By default, the STB uses DHCP, and if a LAN is detected, the STB will request an IP address from the DHCP server on the network as soon as you select "Network Settings." If the STB is able to connect to the network, a "Connected to Internet" message will appear below the Wired Connection (Ethernet) field.

3. If the network is not configured for DHCP, or if you want to enable/disable IPv6, specify static IP configuration data (applicable only for IPv4), or change the network configuration from Manual to Automatic, select **Wired Connection (Ethernet)** and press **OK**.

In the Wired Connection (Ethernet) screen, you can change the IPv6 status and/or edit the IPv4 data for this STB.

4. To enable/disable IPv6, select/highlight the IPv6 field and press **OK**. Then, select **Enabled** or **Disabled** from the drop-down list of options, as applicable.
5. To edit/specify static IPv4 data or change the network configuration from Manual to Automatic, use the arrow keys on the Installer Remote to select **Edit** at the bottom of the screen and press **OK**. Then, in the Edit screen:
 - Select or de-select the "Set Automatically" checkbox, as required. A checkmark indicates that Automatic configuration is enabled.
 - To manually edit the IPv4 data, for each data entry field: Use the arrow keys on the Installer Remote to select the field and press **OK**. You can use the number keys on the Installer Remote to direct enter numeric values or use the arrow keys to select the appropriate characters from the pop-up virtual keyboard displayed at the bottom of the screen. When you are done, select **Enter** from the virtual keyboard, and then press **OK** on the Installer Remote.

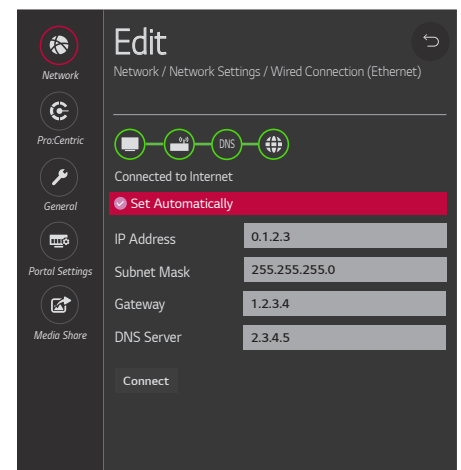
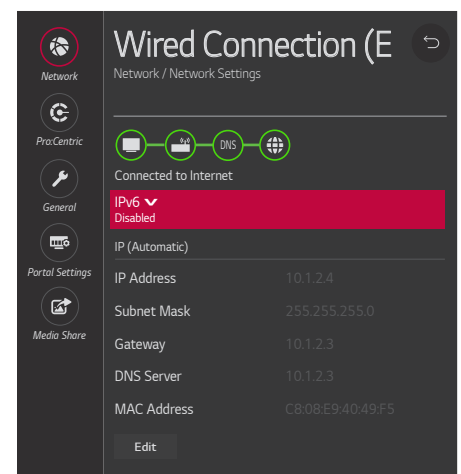
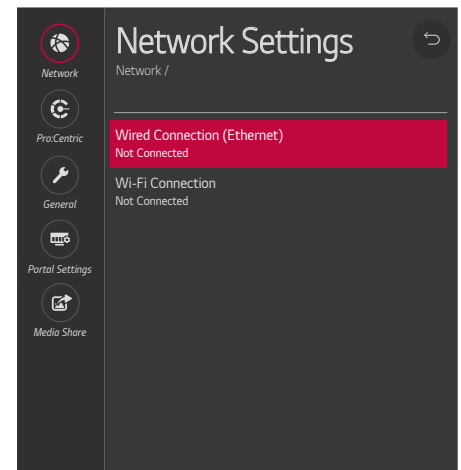

(Continued on next page)

(Continued from previous page)

Note: You must use the dot “.” key from the virtual keyboard to separate each octet of an IP address.

- When all Edit fields are set as required, use the arrow keys on the Installer Remote to select **Connect** and press **OK**.

At the top of the screen, you will see a progress display that indicates status as each network element is confirmed (see example on previous page).

If the network is connected successfully, a “Connected to Internet” message will appear just below the progress display. If the network connection is not successful, the progress display will identify the network element in which the connection failed. Check your cabling and/or verify the configuration data, as necessary.

6. When you are finished, use the arrow keys on the Installer Remote to return to the IP Environment Menu, as necessary, or press ↵ to return to the previous Network Menu level(s) and/or exit the IP Environment Menu.

Configuring a Wi-Fi Network Connection

1. With the Network Menu on display, use the arrow keys on the Installer Remote to select **Network Settings**. Then, press **OK**.
2. A Network Settings screen (see example at right), with Wired and Wi-Fi Connection setup options, will be displayed. Select **Wi-Fi Connection** and press **OK**.
3. The Off/On toggle button at the top right of the Wi-Fi Connection screen (see example on following page) enables you to turn Wi-Fi on or off. The remaining steps of this procedure require that Wi-Fi is turned on. Thus, if necessary, highlight/select the toggle button, and press **OK** to turn on Wi-Fi.
4. Available access points are listed in the top half of the screen, while additional menu options are listed below. Use the arrow keys on the Installer Remote to select the desired access point, or select the type of wireless connection to configure (see descriptions below). Then, press **OK**.
 - Hidden network: Direct enter the SSID—up to 32 characters—of an access point whose SSID has not been enabled for broadcast (i.e., the access point does not appear in the list of access points).
 - WPS PBC: Connect to a network via an access point that is enabled for PBC.
 - WPS PIN: Complete network/PIN verification via the access point web interface.

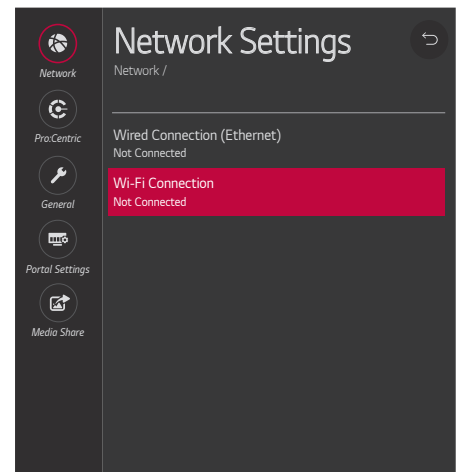

(Continued on next page)

IP Environment Setup (Cont.)

(Continued from previous page)

Make sure you have the network security password—at least eight, but no more than 32 characters—or PIN available if you are attempting to connect to a secured network.

5. Follow the on-screen instructions to complete the appropriate network configuration. Use the Installer Remote to navigate between fields and make entries, etc.

Note: As with a wired connection, you will have the option to enable/disable IPv6 or specify static IPv4 configuration data for this network connection. Once the initial connection is established, you can select **Advanced Wi-Fi Settings** (initially greyed out) at the bottom of the Wi-Fi Connection screen to view the IP configuration data. In the Advanced screen, select **Edit** and press **OK**, and then change the IPv6 status and/or modify the IP data, as required. See steps 4 and 5 of the wired connection procedure above for further information on the Edit screen fields.

6. When you are finished, use the arrow keys on the Installer Remote to return to the IP Environment Menu, as necessary, or press **↩** to return to the previous Network Menu level(s) and/or exit the IP Environment Menu.

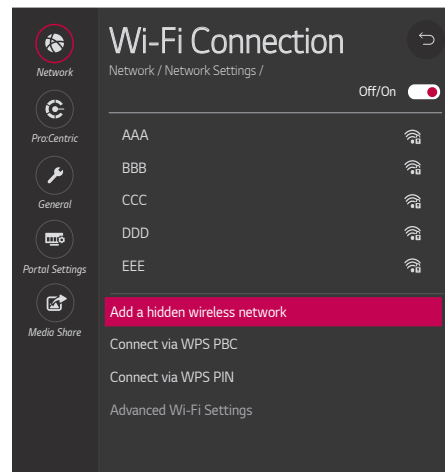

LG Connect

LG Connect allows end users to use LG webOS Connect apps to pair the STB with a mobile device, which can then be used to access and control STB features (i.e., the device may be used as a mobile remote).

LG Connect requires that both the STB and the mobile device be on the same Wi-Fi network. See “Configuring a Wi-Fi Network Connection” above for information on configuring the wireless network connection. This menu option enables you to turn LG Connect either on or off. It also allows you to delete all existing stored device pairings.

1. With the Network Menu on display, use the arrow keys on the Installer Remote to select **LG Connect**. Then, press **OK**.
2. Select/highlight the Off/On toggle button at the top right of the LG Connect Apps screen, and press **OK** on the Installer Remote to turn LG Connect on or off.
3. If you wish to delete all stored device pairings, turn on LG Connect as described in the previous step (if it is not on already), select/highlight the **Revoke Pairing** button (only accessible when LG Connect is turned on), and press **OK** on the Installer Remote. At the prompt for confirmation, either select **Yes** and press **OK** to delete the list of paired devices, or select **No** and press **OK** to return to the LG Connect Menu without deleting stored pairings.
4. When you are finished, use the arrow keys on the Installer Remote to return to the IP Environment Menu, as necessary, or press **↩** to return to the Network Menu and/or exit the IP Environment Menu.

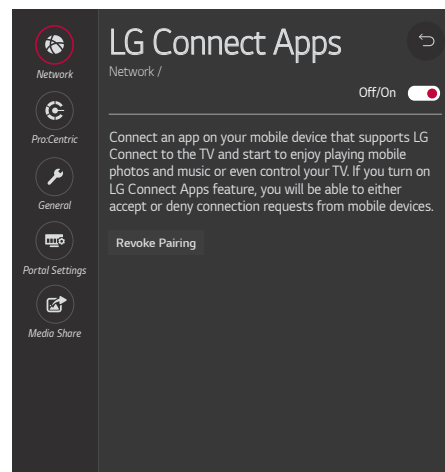

IP Stream Control

If necessary, due to an audio and/or video stream delay, IP Stream Control options enable you to compensate for synchronization irregularities by allowing audio PTS and video PTS offset modifications. This menu also enables you to specify the IGMP version (2 or 3). Note that any modifications to these settings should be performed by qualified personnel only.

1. With the Network Menu on display, use the arrow keys on the Installer Remote to select **IP Stream Control**. Then, press **OK**.
2. In the IP Stream Control screen, use the Up/Down arrow keys on the Installer Remote to select/highlight the appropriate field and press **OK**.
 - To modify an offset value: use the Left/Right arrow keys to select the appropriate value for the selected field. Offset values represent offset time in milliseconds (ms) and can be adjusted from 0 ms to +500 ms in 10 ms increments.
 - To modify the IGMP version: use the Up/Down arrow keys to select the appropriate version number from the drop-down list of options, and then, press **OK**.
3. When you are finished, use the arrow keys on the Installer Remote to return to the IP Environment Menu, as necessary, or press **↵** to return to the Network Menu and/or exit the IP Environment Menu.

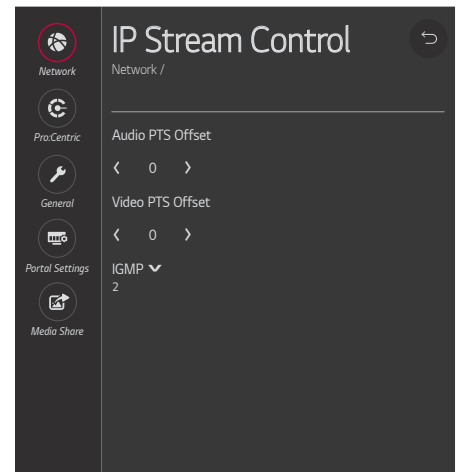

Wake On LAN Setup

The Wake On LAN feature enables the STB to receive software updates and/or be powered ON upon receipt of Magic Packet data via the wired LAN. To facilitate use of this feature, note that the appropriate wired connection must be made. This menu option enables you to specify Wake On LAN parameters.

1. With the Network Menu on display, use the arrow keys on the Installer Remote to select **Wake On LAN**. Then, press **OK**.
2. In the Wake On LAN screen, use the Up/Down arrow keys on the Installer Remote to select/highlight the WOL (Magic Packet) field (if it is not already selected) and press **OK**. Then, use the arrow keys to select the desired setting—Disabled, Update, or Power On—from the drop-down list of options.
3. When you are finished, use the arrow keys on the Installer Remote to return to the IP Environment Menu, as necessary, or press **↵** to return to the Network Menu and/or exit the IP Environment Menu.

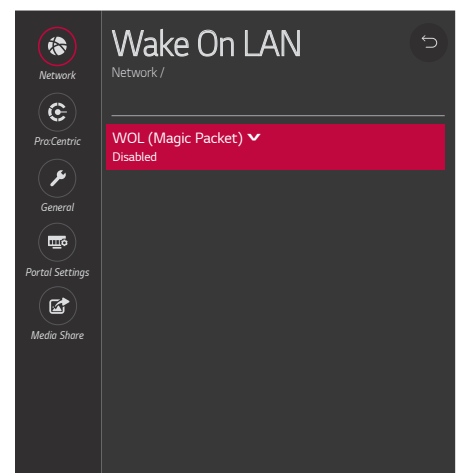

IP Environment Setup (Cont.)

VLAN ID Setup

The VLAN ID option enables you to turn VLAN ID either on or off. It also allows you to specify a VLAN ID for the LAN and Aux LAN* ports.

1. With the Network Menu on display, use the arrow keys on the Installer Remote to select **VLAN ID**. Then, press **OK**.
2. Select/highlight the Off/On toggle button at the top right of the VLAN ID screen, and press **OK** on the Installer Remote to turn VLAN ID on or off. If you would like to specify VLAN IDs as described in step 3, VLAN ID must be turned on.
3. Use the Up/Down arrow keys on the Installer Remote to select/highlight the LAN ID field and press **OK**. You can then use the number keys on the Installer Remote to direct enter the LAN ID, or you can use the arrow keys to select the appropriate number(s) from the pop-up virtual keyboard displayed at the bottom of the screen. When you are done, select **Enter** from the virtual keyboard, and then press **OK** on the Installer Remote.

Repeat this step for the Aux LAN ID field, as applicable.

4. When you are finished, use the arrow keys on the Installer Remote to return to the IP Environment Menu, as necessary, or press **↵** to return to the Network Menu and/or exit the IP Environment Menu.

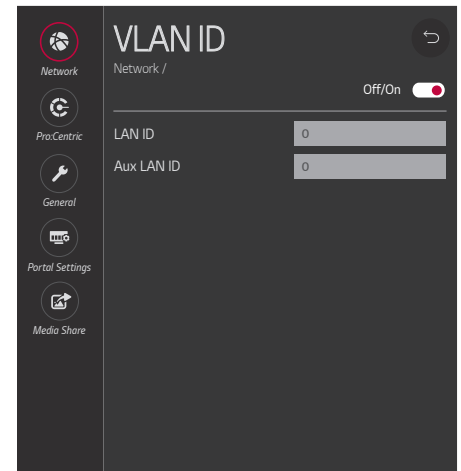

Ping Test

The Ping Test option enables you to ping an IPv4 or IPv6 network address or URL.

1. With the Network Menu on display, use the arrow keys on the Installer Remote to select **Ping Test**. Then, press **OK**.
2. In the Enter the Network Address to Ping pop-up window at the bottom of the screen, use the arrow keys on the Installer Remote to select the desired Type option—IPv4 or IPv6 (i.e., IP Address) or URL.
3. To enter the IP address or URL data, select each data entry field and press **OK**. You can use the number keys on the Installer Remote to direct enter numeric values or use the arrow keys to select the appropriate alphanumeric values (as applicable) from the pop-up virtual keyboard displayed at the bottom of the screen. When you are done, select **Enter** from the virtual keyboard, and then press **OK** on the Installer Remote.
4. When you are ready, select **Begin Test**, and then press **OK** on the Installer Remote.

(Continued on next page)

* Aux LAN port on expansion interface connector.

(Continued from previous page)

The network address will be pinged 10 times and then a summary of the ping statistics will be displayed, for example:

Ping Test Result

Ping statistics for [xxx.xxx.xxx.xxx]

Packets : Sent = 10, Received = 10, Lost = 0 (0% loss)

Approximate round trip times in milliseconds

Minimum = 0.462 ms, Maximum = 5.43 ms, Average = 1.784 ms

5. Select **OK** in the pop-up window, and then press **OK** on the Installer Remote to close the pop-up window when you are finished.

Pro:Centric Setup

Pro:Centric options enable you to configure the STB with the appropriate settings to connect to the Pro:Centric server—either a standard Pro:Centric server installed on-site or a Pro:Centric Cloud server. Use the Up/Down arrow keys on the Installer Remote to navigate between fields.

1. With the IP Environment Menu on display, use the arrow keys on the Installer Remote to select the **Pro:Centric** menu option. Then, press **OK**.

Note: By default, the Pro:Centric Menu initially shows RF configuration fields for a “Standard Pro:Centric Server” Server Type, i.e., a server installed on-site. When “IP” is selected in the Media Type field, Server Address, IP Type, IP Address, and Port Number fields appear on the screen, in place of the Data Channel field. When the Server Type is set to “LG Pro:Centric Cloud,” an Installation Code field is displayed on the screen.

Note: If the Server Type or Media Type has already been set in the Solution Settings / EZ-Manager Wizard, the specified value will be reflected in this field.

2. Select/highlight the **Server Type** field and press **OK** on the Installer Remote to display the drop-down list of options. Then, use the Up/Down arrow keys to select the applicable option:
 - If a Pro:Centric server is installed on-site, select **Standard Pro:Centric Server**.
 - If you will be using LG’s Pro:Centric Cloud solution to configure TVs at the site, select **LG Pro:Centric Cloud**.

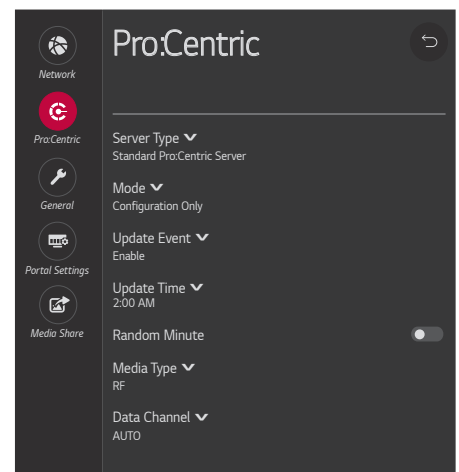

Note: Prior to CPU v3.48.30, Update Event is an On/Off toggle field, and Random Minute is not an option in this menu.

(Continued on next page)

IP Environment Setup (Cont.)

(Continued from previous page)

3. Refer to the appropriate subsection below—"Standard Pro:Centric Server Setup" or "Pro:Centric Cloud Server Setup" based on Server Type—to complete configuration of the STB's Pro:Centric settings.
4. When you are finished, use the arrow keys on the Installer Remote to return to the IP Environment Menu, as necessary, or press **↵** to exit the IP Environment Menu.

Standard Pro:Centric Server Setup

The following procedure describes how to complete the STB's Pro:Centric configuration for a "Standard Pro:Centric Server" Server Type, i.e., a server installed on-site. See example on previous page.

Note: While the Pro:Centric application itself is an additional feature (see step 3), the appropriate Pro:Centric server configuration must be completed to enable E-Z Installation (configuration and software) data downloads and, if configured, the Pro:Centric application download. Thus, this procedure begins with the step to select the Media Type.

1. Select/highlight the **Media Type** field and press **OK** on the Installer Remote to display the drop-down list of options. Then use the Up/Down arrow keys to select either **RF** or **IP**, as applicable.
2. Refer to the appropriate subsection to configure the STB's Pro:Centric settings to match those of the Pro:Centric server.

RF Configuration

For STBs in Pass-through Mode or FTG Mode, if the Data Channel is left at its default value (AUTO), the STB's Data Channel Auto Search feature will be enabled. See Installer Menu item 119 DATA CHANNEL description on page 62.

- To change the Data Channel setting, select/highlight the **Data Channel** field and press **OK** on the Installer Remote. Then, use the Up/Down arrow keys to select either **MANUAL** or **AUTO** from the drop-down list of options.
- When the Data Channel field is set to "MANUAL," a data entry field is available on the screen, and you can specify the RF channel number that will be used by the Pro:Centric server as its data channel. The Data Channel value can be set from 0 (disabled) to 135.*

Use the arrow keys on the Installer Remote to select the Data Channel data entry field and press **OK**. You can then use the number keys on the Installer Remote to direct enter the Data Channel, or you can use the arrow keys to select the appropriate number(s) from the pop-up virtual keyboard displayed at the bottom of the screen. When you are done, select **Enter** from the virtual keyboard, and then press **OK** on the Installer Remote.

Note: If the Data Channel has already been set in the Installer Menu (item 119) or in the Solution Settings / EZ-Manager Wizard, the specified channel will appear in the Data Channel data entry field. If you change the Data Channel in this menu, Installer Menu item 119 will now show the value you entered here.

(Continued on next page)

* PCS150R and later Pro:Centric servers do not support HRC or IRC cable channel frequencies.

(Continued from previous page)

IP Configuration

Note: If the server IP address and port number or domain name have already been set in the Solution Settings / EZ-Manager Wizard, the specified data will be reflected in the fields displayed.

Note: Setting the Media Type to “IP” automatically sets item 119 DATA CHANNEL in the Installer Menu to 253. You cannot alter this setting unless you revert Media Type to “RF.” Also, it is not possible to direct enter “253” in the Installer Menu.

- a) The Server Address field provides the option to specify the domain name of the Pro:Centric server instead of the server’s IP address. Select/highlight the **Server Address** field and press **OK** on the Installer Remote. Then, use the Up/Down arrow keys to select either **IP Address** or **Domain Name** from the drop-down list of options for defining the server.
 - b) Depending on your selection in the previous step, either:
 - Select the appropriate IP type (either IPv4 or IPv6) in the IP Type field, and then enter the Pro:Centric server IP address in the IP Address field. The IP address must match the IPv4 or IPv6 (as applicable) address that is set in the Pro:Centric server.
 - Enter the Pro:Centric server domain name—up to 63 characters (no spaces allowed)—in the Domain Name field. Note that in order for the domain name to be resolved to an IP address, there must be a DNS entry for the domain name.

For each data entry field: Use the arrow keys to select the field and press **OK**. Then, you can either use the number keys on the Installer Remote to direct enter data values, or you can use the arrow keys to select the appropriate number(s)/alphanumeric character(s) from the pop-up virtual keyboard displayed at the bottom of the screen. When you are done, select **Enter** from the virtual keyboard, and then press **OK** on the Installer Remote.
 - c) Enter the Pro:Centric server port number in the Port Number field. The port number must match the port number that is set in the Pro:Centric server.
3. Select/highlight the **Mode** field and press **OK** on the Installer Remote to display the drop-down list of options. Then, use the Up/Down arrow keys to select the appropriate Pro:Centric Application Mode setting—**Configuration Only**, **GEM** (Java), or **HTML**. If the Pro:Centric Application Mode is set to “Configuration Only,” Pro:Centric application data will not be downloaded.

Note: If the mode has already been set in the Installer Menu (item 098 PRO:CENTRIC) or in the Solution Settings / EZ-Manager Wizard, the specified mode will be reflected in this field. If you change the mode in this menu, Installer Menu item 098 will now reflect the value you selected here.
 4. Select/specify the appropriate Update Event setting(s), as required. Based on Update Time settings, the Wake For Update feature wakes the STB once daily to check for, and if applicable, download updates from the Pro:Centric server. See Installer Menu item 121 UPDATE TIME HR description on page 62 for additional information on Wake For Update functionality.

(Continued on next page)

IP Environment Setup (Cont.)

(Continued from previous page)

- Select/highlight the **Update Event** field and press **OK** on the Installer Remote. Then, use the Up/Down arrow keys to select the appropriate Update Event setting—**Enable (Default)** or **Enable**. See Installer Menu item 121 description on page 62 as well as bullets below. Also, note that prior to CPU v3.48.30, Update Event is an On/Off toggle field.
- When Update Event is set to “Enable (Default),” the Update Time field is grayed out, and the update event is scheduled according to the Random Distribution of Update Time described on page 62.
- When Update Event is set to “Enable,” you can specify the Wake For Update time, as required. Select/highlight **Update Time** and press **OK** on the Installer Remote. Then, use the arrow keys to select the appropriate hour, minute, and meridiem values. Note that the Update Time set in this menu is based on a 12-hour clock. Ensure the meridiem (AM/PM) specification is set accordingly.

(Applicable only with CPU v3.48.30 or later) If you wish to invoke the “random” minute assignment on the TV, select/highlight the **Random Minute** field and press **OK** on the Installer Remote to toggle the setting on. In this case, the minute setting in the Update Time field will be disabled.

 **Caution: Update Event should NEVER be set to “Prevent.” This setting is intended for factory use only.**

Pro:Centric Cloud Server Setup

This section describes how to complete the STB’s Pro:Centric configuration for an “LG Pro:Centric Cloud” Server Type (applicable only with CPU v3.44.60 or later and PTC v1.00.010 or later). See example at right.

Note: You will need the six-digit installation code for this property in order to set up the Pro:Centric Cloud (virtual) server configuration. The installation code is generated in the Pro:Centric Cloud portal. A user with an Administrator role for this property must provide/generate the code. The procedure below also assumes this property has already been added to the Pro:Centric Cloud portal. Refer to the **Pro:Centric Cloud Portal User Guide** for further information.

Select/highlight the **Installation Code** field and press **OK** on the Installer Remote. Then, either use the number keys on the Installer Remote to direct enter the installation code, or use the arrow keys to select the appropriate numbers from the pop-up virtual keyboard displayed at the bottom of the screen.

When you are done, select **Enter** from the virtual keyboard, and then press **OK** on the Installer Remote.

The STB will attempt to connect with the server. When the installation code is verified, you will see a “Server Found” message below the Installation Code field.

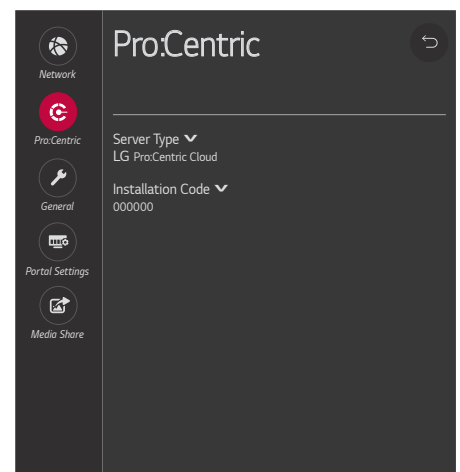

General Options

The General Menu enables you to view and enable varied security settings for this STB. See examples at right, and refer to the appropriate subsection(s) below.

Accessing the General Menu

With the IP Environment Menu on display, use the arrow keys on the Installer Remote to select the **General** menu option. Then, press **OK**.

Security Options

1. With the General Menu on display, use the arrow keys on the Installer Remote to select/highlight **Security**. Then, press **OK**.
2. With the Security Menu on display, you have the options listed below. See also example at right.
 - To view security settings for TCP and UDP ports, use the arrow keys on the Installer Remote to select/highlight **Port Control**. Then, press **OK**.

Security settings for the TCP and UDP ports will be displayed in a new Port Control screen. Blocked ports (if any) are listed in the bottom half of the screen. This list is read-only.

- To view STB information/status details, use the arrow keys on the Installer Remote to select/highlight **STB Information**. Then, press **OK**.

The STB information displayed includes the model, serial number, STB name, webOS version, total power on time, available internal storage, etc.

- To check the status of and/or run diagnosis on selected STB features, use the arrow keys on the Installer Remote to select/highlight **Check Items**. Then, press **OK**. With the Check Items Menu on display, use the arrow keys on the Installer Remote to select/highlight **Check the Status of STB**. Then, press **OK**.

Use the arrow keys on the remote to select/highlight the item you wish to check and press **OK**. Then, follow the instructions on the screen. This feature enables you to check the status of features such as Bluetooth, Wi-Fi, and/or MMR functionality.

- If you would like to set up password protection for the STB Manager, see “STB Manager Password Protection” below.
 - The Software Update option in this menu enables you to update STB software via an NSU web server. Contact your LG service representative for further information. Permission is required for server access.
3. When you are ready to return to the Security Menu, press ↵ on the Installer Remote.

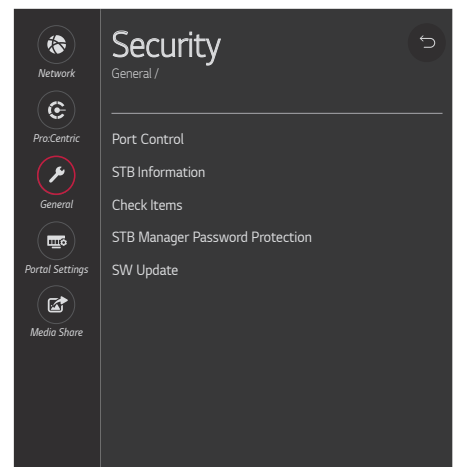
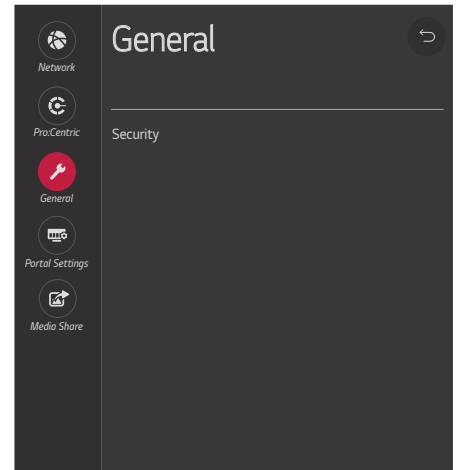

(Continued on next page)

IP Environment Setup (Cont.)

(Continued from previous page)

4. When you are finished in the Security Menu, use the arrow keys on the Installer Remote to return to the IP Environment Menu, as necessary, or press **↵** to return to the General Menu or exit the IP Environment Menu.

STB Manager Password Protection

This option enables you to set a four-digit password for the STB Manager, as an added layer of protection against undesired access. When this feature is enabled, a password prompt is displayed each time a user accesses the STB Manager.

1. With the General Menu on display, use the arrow keys on the Installer Remote to select/highlight **Security**. Then, press **OK**.
2. With the Security Menu on display, use the arrow keys on the Installer Remote to select/highlight **STB Manager Password Protection**. Then, press **OK**. See example at right.

If this feature has never been accessed before, a Set Password prompt will be displayed at the bottom of the screen, along with a virtual keyboard.

3. If the Set Password prompt is displayed, you can either use the number keys on the Installer Remote to direct enter data values, or you can use the arrow keys to select the appropriate numbers from the virtual keyboard. When you are done, select **Enter** from the virtual keyboard, and then press **OK** on the Installer Remote.
4. If you would like to enable/disable password protection, select/highlight the **STB Manager Password Protection** field and press **OK** on the Installer Remote to toggle the setting as required.
5. If you need to reset the password at any time, select **Reset Password** and press **OK**.

An Enter Password prompt will be displayed at the bottom of the screen, along with a virtual keyboard. You can either use the number keys on the Installer Remote to direct enter data values, or you can use the arrow keys to select the appropriate numbers from the virtual keyboard. When you are done, select **Enter** from the virtual keyboard, and then press **OK** on the Installer Remote.

6. If you would like to return to the Security Menu, press **↵** on the Installer Remote.
7. When you are finished in the Security Menu, use the arrow keys on the Installer Remote to return to the IP Environment Menu, as necessary, or press **↵** to return to the General Menu or exit the IP Environment Menu.

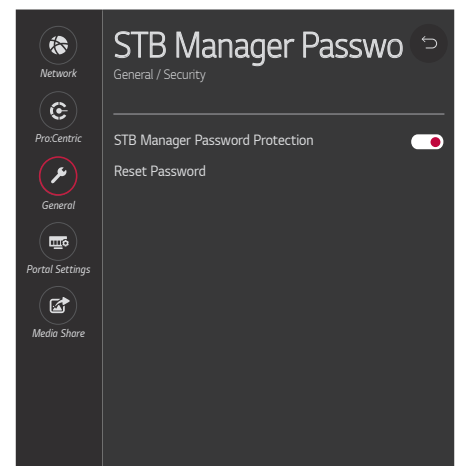

Portal Settings

The Portal Settings Menu enables you to set up a customized local portal for this STB. It also allows you to select which of the pre-loaded application icons to display in the STB/display panel's Smart Launcher. Refer to the appropriate subsection below.

Portal Options

Portal setup options in the Portal Menu are independent of the Pro:Centric portal. If you intend to load a Pro:Centric application on the STB(s) at the site, use the appropriate Pro:Centric Admin Client to configure the portal features.

1. With the IP Environment Menu on display, use the arrow keys on the Installer Remote to select the **Portal Settings** menu option. Then, press **OK**.
2. Select/highlight the **Portal Mode** field and press **OK** on the Installer Remote to display the drop-down list of options. Then, use the Up/Down arrow keys to select the applicable setting—Default Portal, Customizable Portal, or None.

Note: If the Portal Mode has already been set in the Basic Settings Wizard, the specified value will be reflected in this field.

Note: The default value in this field is “Default Portal,” which enables the STB/display panel's standard Smart Launcher. See also “Pre-loaded Applications” below.

3. Select/highlight the **Auto Start** field and press **OK** on the Installer Remote to display the drop-down list of options. Then, use the Up/Down arrow keys to select the applicable setting—Off or Portal Mode. This specifies whether the portal should be displayed each time the STB/display panel is turned ON (as opposed to only being displayed when the end user presses PORTAL on the remote).

Note: If the Auto Start status has already been set in the Basic Settings Wizard, the specified value will be reflected in this field.

4. Use the Website Shortcut, Input Shortcut, Hotel Directory, Portal Editor, and Portal Manager options to create and/or modify the customized portal content, as applicable. You may add up to five website shortcuts and up to seven hotel directories. Follow on-screen instructions to complete the setup.
5. When you are finished in the Portal Settings Menu, use the arrow keys on the Installer Remote to return to the IP Environment Menu, as necessary, or press ↵ to exit the IP Environment Menu.

Note: For further information on the portal settings and options, contact your LG service representative.

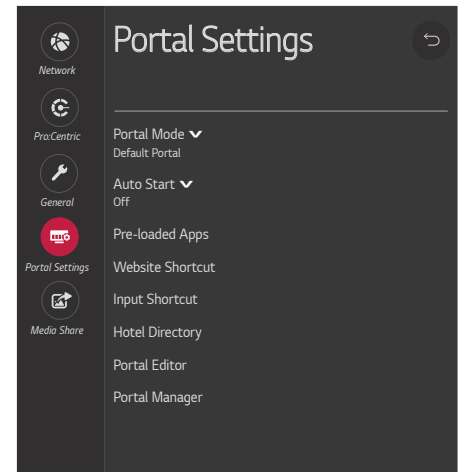

IP Environment Setup (Cont.)

Pre-loaded Applications

This option allows you to select which of the pre-loaded application icons to install/make available in the STB's Smart Launcher, which appears along the bottom of the display screen in the STB's default Portal Mode.

When the Pro:Centric application is disabled, the Smart Launcher is available to end users via the PORTAL key on the remote control. Depending on the remote control being used, the Smart Launcher may also be available to end users via a SMART key.

1. With the IP Environment Menu on display, use the arrow keys on the Installer Remote to select the **Portal Settings** menu option. Then, press **OK**.
2. Make sure the Portal Mode is set to "Default Portal." If necessary, select/highlight the **Portal Mode** field and press **OK** on the Installer Remote to display the drop-down list of options. Then, use the Up/Down arrow keys to select **Default Portal**.
3. Use the arrow keys on the Installer Remote to select **Pre-loaded Apps**. Then, press **OK**.

Application options will be displayed in a new Pre-loaded Apps screen. An App List on the left side of the screen shows the applications that are available, while an Installed App List on the right side of the screen shows the applications that have been installed.

4. You can either install or remove applications on the TV as required. Use the arrow keys on the Installer Remote to make selections.
 - To install apps: Highlight each desired application in the App List, and press **OK** on the Installer Remote. A checkmark indicates that an app is selected.

When you are ready to continue, select/highlight the **Install** button below the App List, and then press **OK** on the Installer Remote. Installation progress will be displayed in a pop-up banner. When the process is complete, press **OK** on the Installer Remote to return to the Pre-loaded Apps screen.

- To remove apps: Highlight each desired application in the Installed App List, and press **OK** on the Installer Remote. A checkmark indicates that an app is selected.

When you are ready to continue, select/highlight the **Delete** button below the Installed App List, and then press **OK** on the Installer Remote. Removal progress will be displayed in a pop-up banner. When the process is complete, press **OK** on the Installer Remote to return to the Pre-loaded Apps screen.

Note: Though not included in the App List, Screen Share and SoftAP (as Wi-Fi Service) applications are available in the Smart Launcher once they are enabled in the Media Share Menu. See "Media Share Setup" below.

(Continued on next page)

(Continued from previous page)

Note: Make sure to select/install any application(s) that may be used in conjunction with the DIAL feature, if applicable.

5. When you are ready to return to the Portal Settings Menu, use the arrow keys on the Installer Remote to select/highlight the **✖** button, and then press **OK**.
6. When you are finished in the Portal Settings Menu, use the arrow keys on the Installer Remote to return to the IP Environment Menu, as necessary, or press **↵** to exit the IP Environment Menu.

Note: While pre-loaded application selections are clonable, it is not possible to edit pre-loaded application selections in the Cloud Configuration Tool. Thus, if an STB has already been configured for FTG Mode and you would like to add or remove applications, you will need to import a new “.tlx” file with the appropriate model profile. That is, you will need to use a Master STB-6500 to create and export a “.tlx” file with the desired pre-loaded application selections (along with any other applicable Installer Menu settings), which can be transferred (imported) to the Target STB.

Media Share Setup

The Media Share Menu allows you to enable the following Media Share features on this STB:

- LG Smart Share[®]: Allows end users to use the STB/display panel to access and view media files (photos, videos, music, etc.) shared by DLNA Certified[®] devices connected to the same LAN as the STB.
- Screen Share: Enables screen sharing with a Miracast[®] or Wireless Display (WiDi) capable device (e.g., a laptop with Intel[®] hardware).
- Media Renderer: Enables the STB to act as a media renderer to receive content from DLNA Certified devices on the same network.
- DIAL (Discovery and Launch): Allows end users to play selected application media on the STB/display panel from a device with DIAL capability. The device may be used to cast any application for which an STB-compatible application has been created/selected for inclusion in the Pre-loaded Apps Menu (for example, YouTube—see also “Pre-loaded Applications” above). Note that the device must be connected to the same network as the STB.
- SoftAP: Enables the STB to function as a wireless access point for up to 10 devices. Note that a wired network connection **MUST** be established in order for end users to use SoftAP.
- Beacon: Enables the STB to function as either an iBeacon[™] or Eddystone[™] beacon device for Bluetooth broadcasting.

Note: See also Reference section, “Using Media Share Features,” for additional information on these features.

(Continued on next page)

IP Environment Setup (Cont.)

(Continued from previous page)

1. With the IP Environment Menu on display, use the arrow keys on the Installer Remote to select the **Media Share** menu option. Then, press **OK**.
2. Smart Share, Media Renderer, and DIAL features may be enabled or disabled as follows: Use the Up/Down arrow keys on the Installer Remote to select/highlight the desired feature, and then press **OK** on the Installer Remote to toggle the setting as required.
3. If you would like to enable Screen Share:
 - Select/highlight **Screen Share**, and then press **OK** to toggle the setting so that Screen Share is on.
 - Then, use the Up/Down arrow keys to select the desired option—**Enable**, **Enable (PIN)**, or **Disable**—from the drop-down list of options.
4. If you would like to enable SoftAP, complete the SoftAP access configuration as follows:

Note: If you select “Enable (PIN),” users will be prompted to enter a randomly generated PIN when connecting a device to the STB.

- Select/highlight **SoftAP** and press **OK** on the Installer Remote.
- Select/highlight the Off/On toggle button at the top right of the SoftAP screen (see example at right), and press **OK** on the Installer Remote to turn on SoftAP.
- To enable use of a randomly generated security key for SoftAP access, select the **Use Default** field, and press **OK** on the Installer Remote to toggle the setting so that the default security key is enabled (the Security Key field will subsequently be grayed out and the random security key will be displayed).
- To specify your own security key for SoftAP access, toggle the Use Default field so that the default security key is disabled. Then, select the **Security Key** field and press **OK**. In the data entry field, you can use the number keys on the Installer Remote to direct enter a numeric security key, or you can use the arrow keys to select the appropriate alphanumeric characters—at least eight, but no more than 64—from the pop-up virtual keyboard displayed at the bottom of the screen.

Note that the security key may not contain any special characters (:, /, \, @, etc.). When you are done, select **Enter** from the virtual keyboard, and then press **OK** on the Installer Remote.

- Select the appropriate values in the Wi-Fi Signal Strength, and Wi-Fi Channel fields, as required.

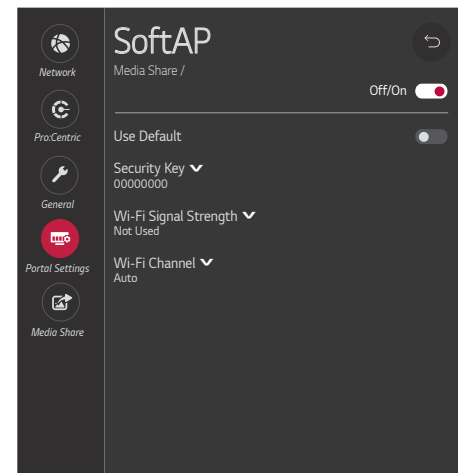
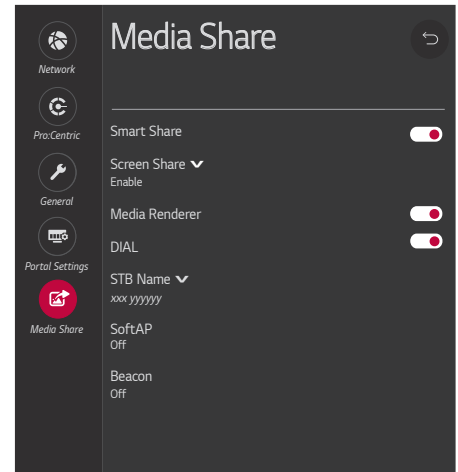

(Continued on next page)

(Continued from previous page)

5. If you would like to enable Beacon, complete the Beacon access configuration as follows:

Note: For iBeacon, you will need to enter the beacon's UUID, Major, and Minor parameters. For Eddystone, you will need to enter the beacon's URL parameters. You should have the pertinent information available before you continue.

- Select/highlight **Beacon** and press **OK** on the Installer Remote.
 - Select/highlight the Off/On toggle button at the top right of the Beacon screen (see example at right), and press **OK** on the Installer Remote to turn on Beacon.
 - Select/highlight the **Type** field and press **OK** on the Installer Remote to display the drop-down list of options. Then, use the Up/Down arrow keys to select the applicable Beacon type—either iBeacon or Eddystone.
 - Select each data entry field in turn, and provide the appropriate information. In the data entry fields, you can use the number keys on the Installer Remote to direct enter numbers, or you can use the arrow keys to select the appropriate alphanumeric characters from the pop-up virtual keyboard displayed at the bottom of the screen. When you are done, select **Enter** from the virtual keyboard, and then press **OK** on the Installer Remote.
 - When you have entered all the beacon identification data, select the **OK** button at the bottom of the menu, and then press **OK** on the Installer Remote.
 - At the prompt for broadcast confirmation, select either **Yes** to broadcast the Beacon or **No** to decline to broadcast the Beacon.
6. If desired, you can specify a name for this STB so that it is easy to identify and differentiate from other STBs/TVs for which sharing has been/will be enabled.

Note: By default, the STB name is “[LG] webOS STB.” However, if a room number is specified in the Solution Settings / EZ-Manager Wizard or in the (setup menus) General Menu / Room Info screen, the STB name is changed to the room number.

To edit the STB name, use the Up/Down arrow keys to select the **STB Name** field, and then press **OK**. You can then use the number keys on the Installer Remote to direct enter a numeric STB name, or you can use the arrow keys to select the appropriate alphanumeric character(s) from the pop-up virtual keyboard at the bottom of the screen. When you are done, select **Enter** from the virtual keyboard, and then press **OK** on the Installer Remote.

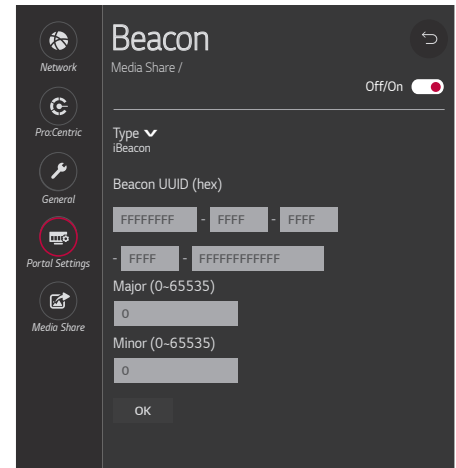

(Continued on next page)

IP Environment Setup (Cont.)

(Continued from previous page)

7. When you are finished, use the arrow keys on the Installer Remote to return to the IP Environment Menu, as necessary, or press **↵** to exit the IP Environment Menu.

Note: After all Media Share feature settings are done, reboot the STB to complete each setup. If you intend to modify additional menu settings, unless prompted otherwise, you may wait until all changes are complete before you reboot the STB.

Note: While Smart Share, Screen Share, Media Renderer, DIAL, and Beacon settings are clonable, SoftAP settings, as well as the STB name cannot be cloned.

Reference: Updating STB Software using a USB Memory Device

This section describes how to update STB (CPU) and/or PTC software using the STB Manager “Update STB Software” and/or “Update PTC Software” option(s), respectively, though you may also use the Ez Download utility to update software, if desired. See “Ez Download Utility” on pages 45 to 49 for further information.

Before You Begin

- Software update files must be stored in a folder named “LG_DTV” in the root directory of the USB memory device.
- Ensure the USB device has been formatted with FAT format.

Update the STB/PTC Software

Note: You can check the STB/PTC software versions by accessing the Installer Menu with the Installer Remote. See “Accessing the Installer Menu” on page 50 for further information. PTC and CPU versions are displayed in the Installer Menu footer.

Note for STB CPU Software Update only: If the STB detects a software file on the USB device, it will automatically display an Update STB Software screen, and if the file contains a later version of software than is currently running on the STB, you can start the software update from this screen (select **Update** and press **OK**). Otherwise, you can exit the screen (select **Cancel** and press **OK**), and access the STB Manager as described below.

1. Turn ON the STB/display panel, and then insert the USB memory device into either of the USB ports on the STB.
2. Press **MENU** on the Installer Remote to display the STB setup menus (STB is in Pass-through Mode) or the Function Menu (STB is not in Pass-through Mode).
3. (STB in Pass-through Mode only) From the Quick Settings Menu displayed at the left of the screen, select the **All Settings**  menu icon and press **OK** to access the advanced STB setup menus.
4. Use the arrow navigation keys to select/highlight either the **General** menu icon from the STB setup menus or the **Safety** menu icon from the Function Menu. Then, press the number “7” key a total of seven times to display the STB Manager (see example on following page).

Note: If a password prompt is displayed (i.e., STB Manager Password Protection is enabled in the IP Environment / General Menu), key in the STB Manager password and press **OK**.

Note: Ez Download is always selected by default when you initially access the STB Manager. Also note that Diagnostics is for service use only.

5. If more than one USB memory device is currently connected to the STB, be sure to select the USB device that contains the applicable software file. If necessary, use the arrow keys on the Installer Remote to select/highlight the **USB Device** button in the top right corner of the screen and press **OK**. Then, use the Up/Down arrow keys to select the appropriate USB device from the pop-up list of USB devices displayed at the top of the screen.

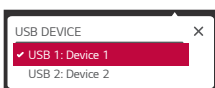

(Continued on next page)

Reference: Updating STB Software using a USB Memory Device (Cont.)

(Continued from previous page)

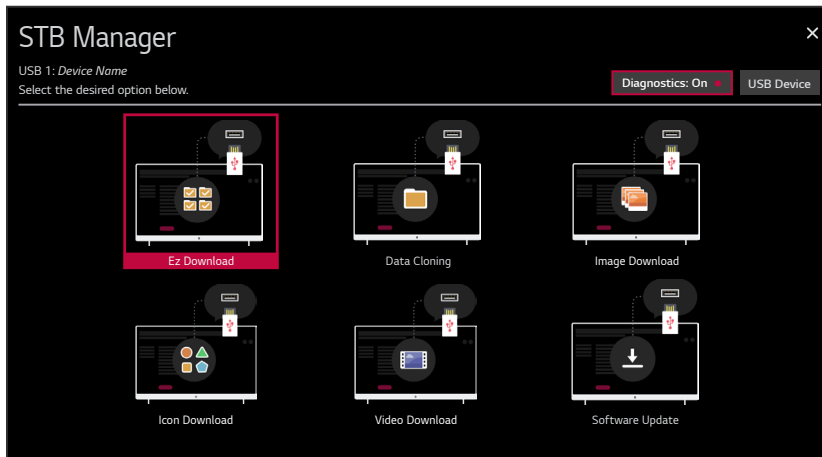

6. Use the arrow keys to select **Software Update**, and then press **OK**.
7. Use the Up/Down arrow keys to select **Update STB Software** or **Update PTC Software**, as applicable, and press **OK**.

Depending on your selection, a list of either STB or PTC software files stored in the LG_DTV folder on the USB memory device will be displayed on the screen. Above the listing of files, you can also see the current version of STB or PTC software. The following example illustrates an Update STB Software screen.

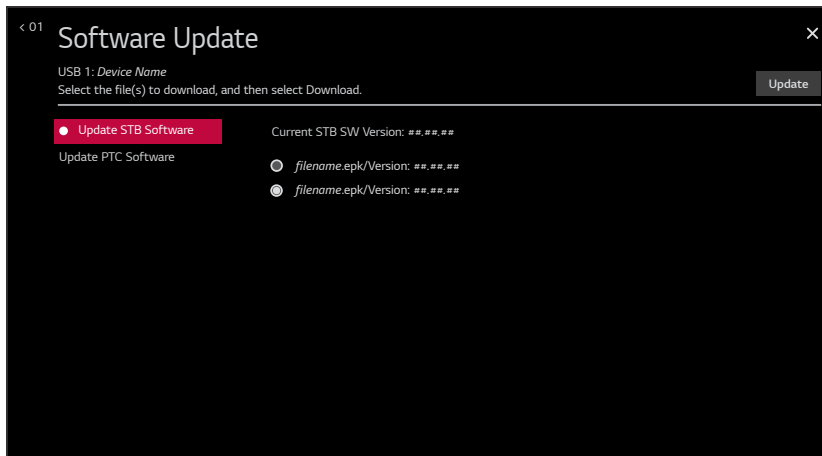

8. Use the arrow keys to select/highlight the update file to download, and then press **OK**.
9. When you are ready to download the update, select **Update** on the screen, and then press **OK** on the Installer Remote.

Software update progress will be displayed on the screen. Do NOT remove the USB device until the software update is complete. When the software update is complete, a "Software Update is completed" pop-up message will briefly be displayed on the screen, and then, the STB will reboot.

Reference: Downloading Images or Icons using a USB Memory Device

This section describes how to download the image types listed below using the STB Manager “Image Download” or “Icon Download” options, though you may also use the Ez Download utility to download the image(s), if desired. See “Ez Download Utility” on pages 45 to 49 for further information.

- Background images are intended for use with audio-only channels and applications, such as the Bluetooth Sound Sync feature or the Clock application, that by default have static backgrounds. End users may choose to display a slideshow on the screen while audio is playing. Up to 12 images may be selected.
- Hotel Directory images are intended for use with a local customized portal. Up to 12 images may be selected for up to six hotel directories.
- The Hotel Icon on Portal icon image is used for local customized portal branding. One icon image may be selected.
- Website Shortcuts are icon images. One icon image may be selected for up to five website directories.

Background and Hotel Directory Image File Guidelines

- File formats supported: Baseline or progressive JPEG, JPG, or PNG.
- Up to 12 image files (no more than 10 MB total) may be selected for background images and/or for hotel directories.
- The maximum resolution allowed for Background and Hotel Directory images is 3840 x 2160 pixels.
- Avoid using special characters, such as ?, &, @, etc., in a background image filename.

Icon Image File Guidelines

- File formats supported: Baseline or progressive JPEG, JPG, or PNG.
- An icon image should be no larger than 10 MB.
- The maximum resolution allowed for Hotel Icon on Portal and Website Shortcut images is 3840 x 2160 pixels.
- Avoid using special characters, such as ?, &, @, etc., in image filenames.

Before You Begin

- The image file(s) must be stored in a folder named “LG_DTV” in the root directory of the USB memory device.
- Ensure the USB device has been formatted with FAT format.

Download the Image(s)

1. Turn ON the STB/display panel, and then insert the USB memory device into either of the USB ports on the STB.
2. Press **MENU** on the Installer Remote to display the STB setup menus (STB is in Pass-through Mode) or the Function Menu (STB is not in Pass-through Mode).

(Continued on next page)

Reference: Downloading Images or Icons using a USB Memory Device (Cont.)

(Continued from previous page)

3. (STB in Pass-through Mode only) From the Quick Settings Menu displayed at the left of the screen, select the **All Settings**  menu icon and press **OK** to access the advanced STB setup menus.
4. Use the arrow navigation keys to select/highlight either the **General** menu icon from the STB setup menus or the **Safety** menu icon from the Function Menu. Then, press the number “7” key a total of seven times to display the STB Manager.

Note: If a password prompt is displayed (i.e., STB Manager Password Protection is enabled in the IP Environment / General Menu), key in the STB Manager password and press **OK**.

Note: Ez Download is always selected by default when you initially access the STB Manager. Also note that Diagnostics is for service use only.

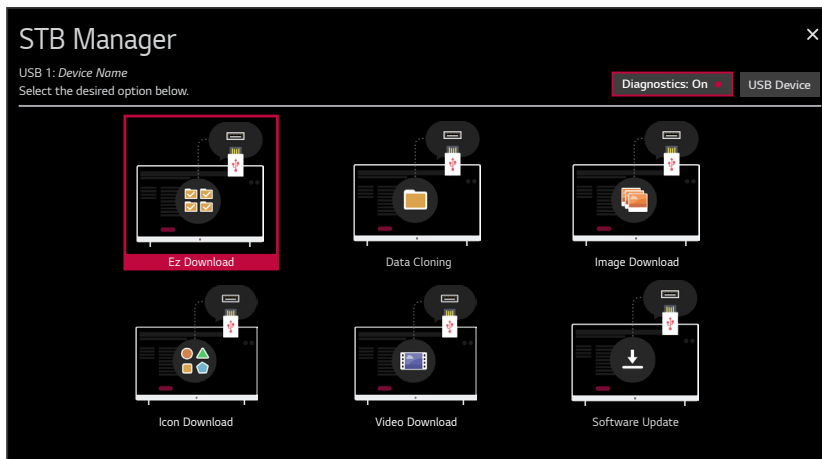

5. If more than one USB memory device is currently connected to the STB, be sure to select the USB device that contains the applicable image file(s). If necessary, use the arrow keys on the Installer Remote to select/highlight the **USB Device** button in the top right corner of the screen and press **OK**. Then, use the Up/Down arrow keys to select the appropriate USB device from the pop-up list of USB devices displayed at the top of the screen.

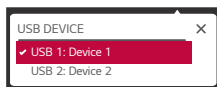

6. Use the arrow keys to select **Image Download** or **Icon Download**, as applicable, and then press **OK**.

Depending on your selection, either the Image Download or Icon Download screen will be displayed. The example below illustrates an Image Download screen.

Note: You can select the  (Storage) button at the top of the screen to check the amount of storage available for and currently in use by media (image, icon, and video) files. Storage data will be displayed in a pop-up window. When you are finished, select **OK** to close the pop-up

(Continued on next page)

Reference: Downloading Images or Icons using a USB Memory Device (Cont.)

(Continued from previous page)

window. If you would like to clear all of the image or icon (depending on your selection in step 6) files currently in storage, select the **Clear Storage** button. Then, in the confirmation pop-up window, select **Yes** to clear the files, or select **No** to return to the Image Download or Icon Download screen, as applicable, without clearing the files.

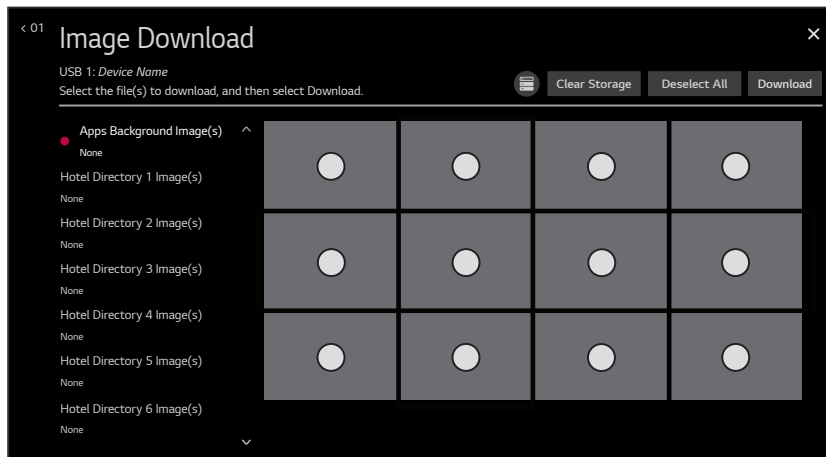

7. Use the Up/Down arrow keys to select the appropriate option from the list of file types at the left of the screen, and then press **OK**.
8. In the image area at the right of the screen, use the arrow keys to select/highlight the image file(s) to download. Press **OK** to select a file (a checkmark identifies a selected file). See also image guidelines at the beginning of this section.
9. When you are ready to download the image file(s), select **Download** on the screen, and then press **OK** on the Installer Remote.

Download progress will be displayed on the screen. Do NOT remove the USB device until the image download(s) is/are complete. When the download process is complete, an "Image Download is completed" or "Icon Download is completed" message will be displayed on the screen (in accordance with your selection in step 6), and a "Done" button will be displayed/activated at the top right of the screen.

10. Check the download status—at the left of the screen—for each image to make sure the download was successful, and then press **OK** on the Installer Remote to select **Done**.

When you select "Done," the Image Download or Icon Download screen (depending on your selection in step 6) will be redisplayed, and you can download additional images and/or perform other STB Manager functions, as required.

Reference: Downloading a Hotel Video using a USB Memory Device

This section describes how to download a hotel video using the STB Manager “Video Download” option, though you may also use the Ez Download utility to download the video, if desired. See “Ez Download Utility” on pages 45 to 49 for further information.

One hotel video may be selected for a local customized portal.

Video File Guidelines

- File formats supported: DIVX, AVI, MKV, MP4, 3GP, 3G2, TS, TP, TRP, MPG, MPEG, VOB, VRO, ASF, WMV, MOV, DAT, F4V, FLV, TTS, ASX, M4V, K3G, M2TS, MPE, MTS, WEBM, LGE, LG2, LGV, MZ.
- The video size is only restricted by the STB’s storage capacity. You be will able to check the amount of space available from the Video Download screen, as described in the procedure below.
- Avoid using special characters, such as ?, &, @, etc., in the video filename.

Before You Begin

- The video file must be stored in a folder named “LG_DTV” in the root directory of the USB memory device.
- Ensure the USB device has been formatted with FAT format.

Download the Video

1. Turn ON the STB/display panel, and then insert the USB memory device into either of the USB ports on the STB.
2. Press **MENU** on the Installer Remote to display the STB setup menus (STB is in Pass-through Mode) or the Function Menu (STB is not in Pass-through Mode).
3. (STB in Pass-through Mode only) From the Quick Settings Menu displayed at the left of the screen, select the **All Settings**  menu icon and press **OK** to access the advanced STB setup menus.
4. Use the arrow navigation keys to select/highlight either the **General** menu icon from the STB setup menus or the **Safety** menu icon from the Function Menu. Then, press the number “7” key a total of seven times to display the STB Manager (see example on following page).

Note: If a password prompt is displayed (i.e., STB Manager Password Protection is enabled in the IP Environment / General Menu), key in the STB Manager password and press **OK**.

Note: Ez Download is always selected by default when you initially access the STB Manager. Also note that Diagnostics is for service use only.

(Continued on next page)

Reference: Downloading a Hotel Video using a USB Memory Device (Cont.)

(Continued from previous page)

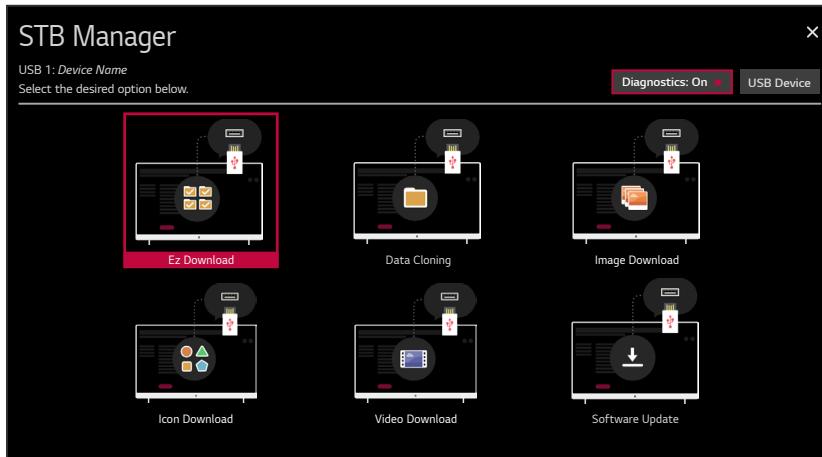

5. If more than one USB memory device is currently connected to the STB, be sure to select the USB device that contains the applicable video file. If necessary, use the arrow keys on the Installer Remote to select/highlight the **USB Device** button in the top right corner of the screen and press **OK**. Then, use the Up/Down arrow keys to select the appropriate USB device from the pop-up list of USB devices.



6. Use the arrow keys to select **Video Download**, and then press **OK**. The Video Download screen will be displayed.

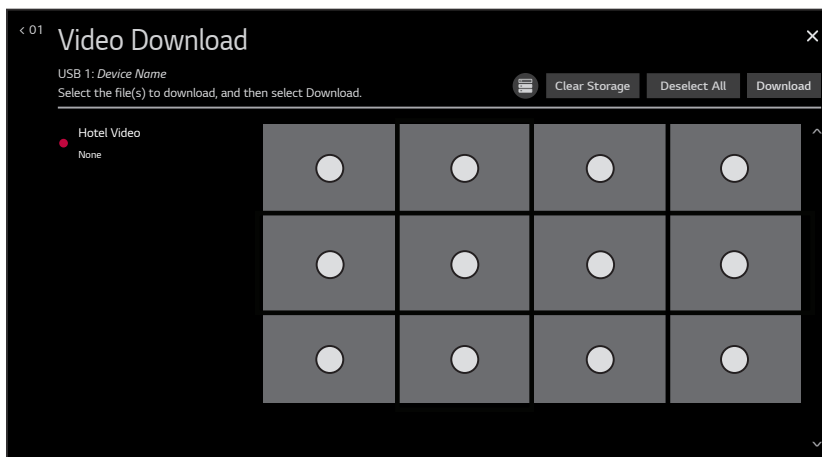

(Continued on next page)

Reference: Downloading a Hotel Video using a USB Memory Device (Cont.)

(Continued from previous page)

Note: You can select the  (Storage) button at the top of the screen to check the amount of storage available for and currently in use by media (image, icon, and video) files. Storage data will be displayed in a pop-up window. When you are finished, select **OK** to close the pop-up window. If you would like to clear the video file currently in storage, select the **Clear Storage** button. Then, in the confirmation pop-up window, select **Yes** to clear the video file, or select **No** to return to the Video Download screen without clearing the video file.

7. In the thumbnail area at the right of the screen, use the arrow keys to select/highlight the video file to download. Press **OK** to select a file (a checkmark  identifies a selected file). See also video guidelines at the beginning of this section.

8. When you are ready to download the video file, select **Download** on the screen, and then press **OK** on the Installer Remote.

Download progress will be displayed on the screen. Do NOT remove the USB device until the video download is complete. When the download process is complete, a “Video Download is completed” message will be displayed on the screen, and a “Done” button will be displayed/activated at the top right of the screen.

9. Check the download status—at the left of the screen—for the video to make sure the download was successful, and then press **OK** on the Installer Remote to select **Done**.

When you select “Done,” the Video Download screen will be redisplayed, and you can perform other STB Manager functions, as required.

Reference: Downloading a Pro:Idiom Media Key using a USB Memory Device

System providers may now define and apply their own Pro:Idiom Media Key (.pim) file to STBs at an installation site. This section describes how to download the Pro:Idiom Mobile Key file using the STB Manager Ez Download utility. Contact your LG service representative for further information on this feature.

Before You Begin

- Obtain the proper Pro:Idiom Media Key (.pim) file from the system provider. Avoid using special characters, such as ?, &, @, etc., in the filename.
- The Pro:Idiom Media Key file must be stored in a folder named “LG_DTV” in the root directory of the USB memory device.
- Ensure the USB device has been formatted with FAT format.

Download the Pro:Idiom Media Key File

 **Caution: If you restore the STB to a factory default condition, the default Pro:Idiom Media key will also be restored.**

1. Turn ON the STB/display panel, and then insert the USB memory device into either of the USB ports on the STB.
2. Access the Ez Download utility, and select the appropriate USB memory device, as applicable (see “Ez Download Utility” on pages 45 to 49 for further information).
3. With the Ez Download screen on display, use the Up/Down arrow keys to select **Download Pro:Idiom M Key**, and then press **OK**.

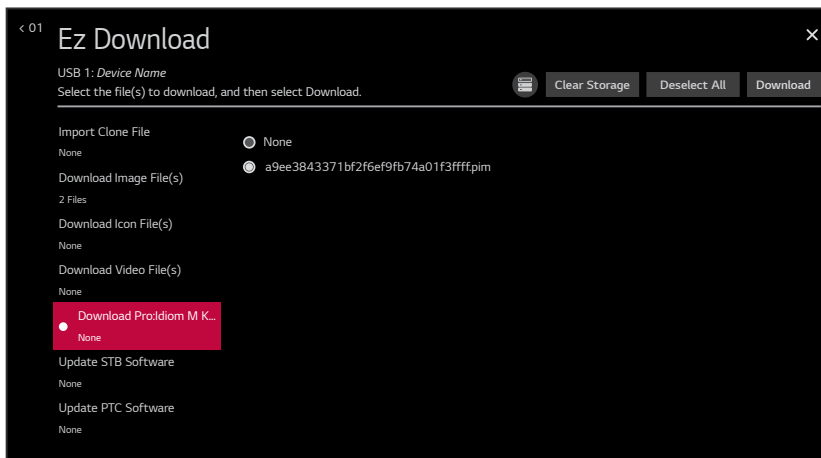

4. Use the arrow keys to select/highlight the Pro:Idiom Media Key file to download.
5. When you are ready to download the file, select **Download** on the screen, and then press **OK** on the Installer Remote.

Download progress will be displayed on the screen. Do NOT remove the USB device until the download is complete. When the Ez Download process is complete, an overview of the results will briefly be displayed and then, the STB will reboot.

6. Remove the USB memory device, and verify that the appropriate Pro:Idiom key is resident on the STB.

Reference: Display Panel Specifications

This section describes the types of commercial display panels that may be used with the STB-6500.

LG Hospitality TV Panels

The STB-6500 may be used with LG Hospitality TVs (LW570H, UW660H, etc.) that support Multiple Protocol Interface (MPI).

Use the MPI/MTI cable provided to connect the RJ-12 MPI/MTI TELEVISION CONTROL port on the STB-6500 front jack panel to the MPI port on the rear jack panel of the display.

LG Commercial Monitors & Public Display TV Panels

The STB-6500 may be used with LG Commercial Monitors (M3203CCBA, M3204C, etc.) or Public Display TVs (LV340H, UT340H, etc.) that support the TV-Link Monitor (TLM) interface.

Use the 3.5 mm-to-DB9 TLM cable provided to connect the 3.5 mm RS-232C TELEVISION CONTROL jack on the STB-6500 rear jack panel to the RS-232 CONTROL connector on the rear jack panel of the display.

Note that when you use these model display panels, you must set Installer Menu item 113 PANEL TYPE appropriately. For example, if you are using an LG Commercial Monitor or Public Display TV that does not support an xb Input Select command, set Installer Menu item 113 to 2. If you are using an LG Commercial Monitor or Public Display TV that does support an xb Input Select command, set Installer Menu item 113 to 4 (default).

Note: Installer Menu item 113 values 0, 1, and 3 are available to support legacy panel types.

Commercial Non-LG TV Panels

The STB-6500 may be used with commercial non-LG TVs that support SONIFI's Multiple Television Interface (MTI) protocol.

Use the MPI/MTI cable provided to connect the RJ-12 MPI/MTI TELEVISION CONTROL port on the STB-6500 front jack panel to the MTI (typically labeled "DATA") port on the rear jack panel of the display.

Note that some MTI interface configuration may be required on non-LG TVs. Refer to the TV manufacturer's documentation to determine if any configuration is required. Also, you will need to enable the MTI protocol (disabled by default) in the STB. See Reference section, "Enabling or Disabling the MTI Protocol on the STB," for further information.

Reference: STB Aux Input Configuration

DIRECT ACCESS Tuning*		STB		ENABLE					MPI DATA				Installer Menu Item 046 START AUX SRCE (Start Aux Source) Value
				Installer Menu			MPI DATA STATUS TYPE 0x41 SOURCES ENABLED (R/W)	DATA STATUS TYPE 0xD2 CURRENT AV SOURCE (R)	DATA STATUS TYPE 0x0D AUX SOURCE (R)				
Installer Menu Item 029 REMAP AUX INPS = 0	Installer Menu Item 029 REMAP AUX INPS = 1	Aux Input	Input Mode	Item	Function	Value	Enable Bit	Label	Value	Value	Description		
131-0	91-0	AV	CV	39	REAR AUX EN	1	1	Rear Video (Aux)	1	0	VIDEO	1	
132-0	92-0	HDMI 2	DTV	91	HDMI2 ENABLE	1	2	S-Video Rear	2	0	VIDEO	5	
			PC			2				2	COMPUTER		
133-0	93-0	HDMI 1	DTV	35	HDMI1 ENABLE	1	3	Front Computer	3	0	VIDEO	3	
			PC			2				2	COMPUTER		
135-0	95-0	HDMI 3**	DTV	92	HDMI3 ENABLE	1	5	NTSC Rear Computer	5	0	VIDEO	7	
			PC			2				2	COMPUTER		

* Use Installer Remote to enter channel number indicated based on REMAP AUX INPS Installer Menu setting.

** HDMI 3 port on expansion interface connector.

Note: To add Aux inputs to an FTG Channel Map, use analog channel numbers in the 130 range, per table above, as the physical RF channel.

Reference: Auto Input(s) Sensing Feature

This section provides detailed settings information for Installer Menu item 042 AUTO INPUTS. To disable auto-sensing for all available STB Aux inputs, set item 042 to 0. To enable auto-sensing for all available STB Aux inputs, set item 042 to 255. For specifications on all other available settings (i.e., settings for individual inputs), refer to the Auto Inputs Values table on the following page.

Note: When both item 042 AUTO INPUTS *and* item 041 SIMPLINK EN are enabled in the Installer Menu, the STB's HDMI inputs will be detected by SIMPLINK, but the Auto Input(s) Sensing Feature will not function.

In the Installer Menu, an informational text code is displayed at the right of each Auto Inputs value, for example:

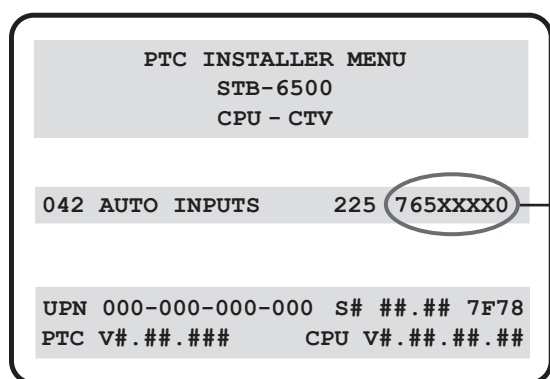

AUTO INPUTS Text Code

This example illustrates Installer Menu item 042 value 225, which enables auto-sensing for all available STB Aux inputs. The input #s in the text code (7, 6, 5, 0 in this example) identify the enabled Aux inputs. See the Input # Assignments table below for a listing of the STB-6500 Aux inputs and their corresponding text code input #s. The Auto Inputs Values table on the following page shows the text codes for all item 042 values.

Each Auto Inputs text code consists of eight characters that identify the STB Aux input(s) for which auto-sensing is enabled. The following table identifies the Installer Menu text code input # for each Aux input that is available on the STB-6500. The table also identifies the Installer Menu item associated with each Aux input. Remember that in order for auto-sensing to be enabled for an input, that input must also be enabled in the Installer Menu.

Input # Assignments

Installer Menu Text Code Input #	STB Aux Input	Installer Menu	
		Item	Function
0	AV	039	REAR AUX EN
6	HDMI 1	035	HDMI1 ENABLE
7	HDMI 2	091	HDMI2 ENABLE
5	HDMI 3*	092	HDMI3 ENABLE

* HDMI 3 port on expansion interface connector.

Reference: Auto Input(s) Sensing Feature (Cont.)

The following table shows all available Aux inputs as if each is enabled in the Installer Menu. The Installer Menu text codes for item 042 will be altered accordingly if any of the available Aux inputs are disabled in the Installer Menu.

Auto Inputs Values

Item 042 Value	STB Aux Inputs				Installer Menu Text Code
	AV	HDMI 1	HDMI 2	HDMI 3*	
000	Disabled	Disabled	Disabled	Disabled	DDXXXXD
001	Enabled	Disabled	Disabled	Disabled	DDXXXX0
032	Disabled	Disabled	Disabled	Enabled	DD5XXXXD
033	Enabled	Disabled	Disabled	Enabled	DD5XXXX0
064	Disabled	Enabled	Disabled	Disabled	D6DXXXXD
065	Enabled	Enabled	Disabled	Disabled	D6DXXXX0
096	Disabled	Enabled	Disabled	Enabled	D65XXXXD
097	Enabled	Enabled	Disabled	Enabled	D65XXXX0
128	Disabled	Disabled	Enabled	Disabled	7DDXXXXD
129	Enabled	Disabled	Enabled	Disabled	7DDXXXX0
160	Disabled	Disabled	Enabled	Enabled	7D5XXXXD
161	Enabled	Disabled	Enabled	Enabled	7D5XXXX0
192	Disabled	Enabled	Enabled	Disabled	76DXXXXD
193	Enabled	Enabled	Enabled	Disabled	76DXXXX0
224	Disabled	Enabled	Enabled	Enabled	765XXXXD
225	Enabled	Enabled	Enabled	Enabled	765XXXX0
255	Enabled	Enabled	Enabled	Enabled	765XXXX0

X = Aux input is Disabled or Not Available (i.e., on this STB model)

D = Auto-sensing for input is Disabled

Input # = Auto-sensing for input is Enabled

* HDMI 3 port on expansion interface connector.

Reference: Enabling or Disabling the MTI Protocol on the STB

This section describes how to enable or disable the MTI protocol on the STB. Refer to the appropriate procedure below depending on whether you would like to complete the steps via the Installer Menu or using the Cloud Configuration Tool. By default, the MTI protocol is disabled.

If you do not see the STB's video output on the display, use the display panel's IR remote to manually switch the display panel to the appropriate HDMI input so that you can complete the required procedure.

⚠ Caution: When the MTI protocol (used with commercial non-LG displays) is enabled, both MPI and the TLM interface (used with LG Commercial displays) automatically are disabled. And vice versa. If you decide to use the STB with a different display panel in the future, you will need to make sure that the MTI protocol is enabled or disabled appropriately.

Enable/Disable the MTI Protocol via the Installer Menu

1. Use the Installer Remote to access the STB's Installer Menu, and navigate to Installer Menu item 113 PANEL TYPE.

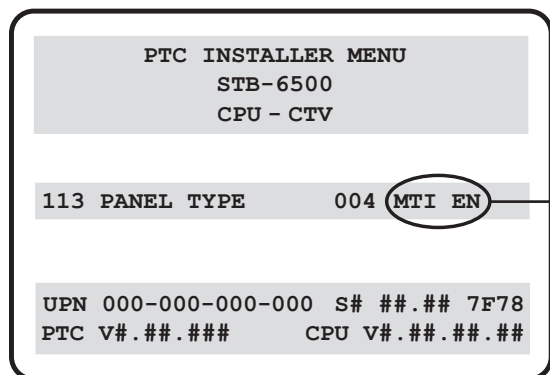

MTI Code

This example indicates that the MTI protocol is enabled. If the MTI protocol is disabled, no text will appear here.

2. Either:

- Press **719 + OK** on the Installer Remote to enable the MTI protocol.
- Press **719 + EXIT** on the Installer Remote to disable the MTI protocol.

Enable/Disable the MTI Protocol using the Cloud Configuration Tool

This procedure describes how to modify the MTI protocol setting using the Cloud Configuration Tool. Once you save the new .tlx file, you can transfer (import) it to a Target STB using a USB memory device.

Note: If the EZ-Manager Wizard appears on the screen when you turn ON the Target STB/display panel, you can use the wizard's "USB Configuration" option to access the STB Manager and complete the import procedure (see "STB Configuration Options" and/or "USB Configuration" on pages 32 and 43, respectively, as necessary). See also "Importing a Clone File" on pages 69 to 73 for further information.

1. Access the Cloud Configuration Tool, and upload an existing file and/or create an STB-6500 Installer Menu profile, as necessary (see "Creating an FTG Configuration File" on pages 74 to 77 for further information).

(Continued on next page)

Reference: Enabling or Disabling the MTI Protocol on the STB (Cont.)

(Continued from previous page)

2. In the Cloud Configuration Tool / Installer Menu web page, click on Installer Menu item #113 Panel Type in the Summary tab, or click on the STB I/O tab.
3. Type **MTI** in the text field at the bottom of the #113 Panel Type options. An “MTI Disable” checkbox will be displayed (with a checkmark if the MTI protocol is currently disabled or without a checkmark if the MTI protocol is currently enabled). See example below.

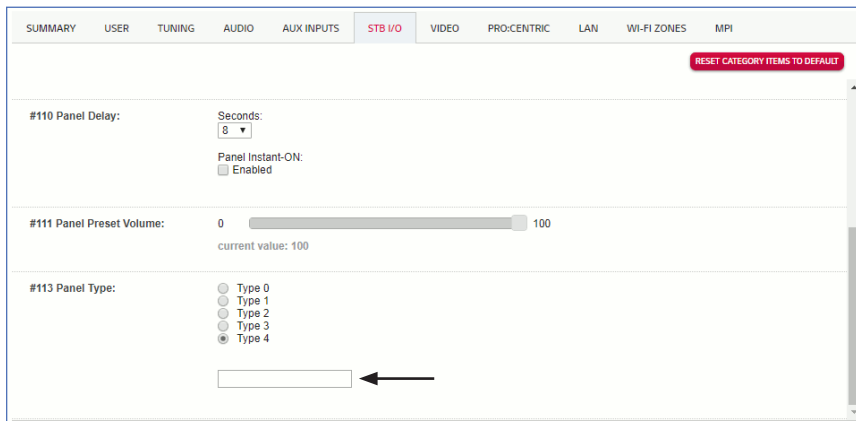

4. Either:

- Click the “MTI Disable” checkbox to remove the checkmark and enable the MTI protocol.
- Click the “MTI Disable” checkbox to add the checkmark and disable the MTI protocol.

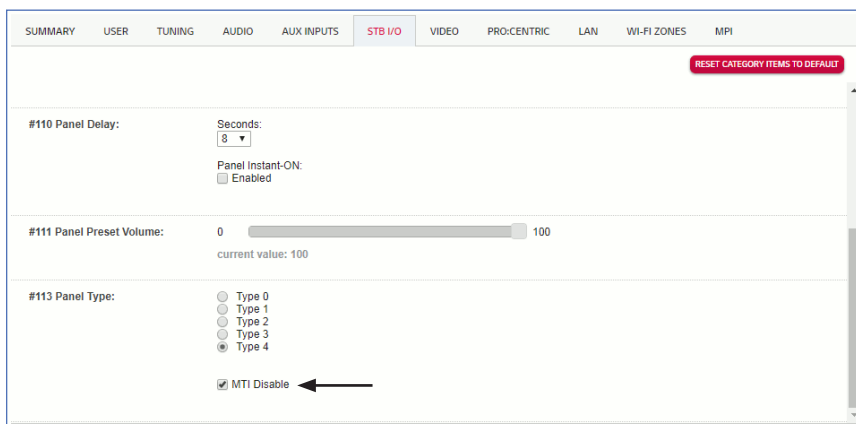

Reference: Restoring Factory Defaults on the STB(s)

This section describes how to restore all factory defaults or just the Installer Menu factory defaults either on a single STB that is currently in Pass-through Mode, FTG Mode, Application Tuning Mode, etc. or on multiple STBs that are currently in FTG Mode.

Restore All Factory Defaults

This section describes how to restore a single STB, regardless of its current mode, to a factory default condition. The following procedure requires that you contact LG technical support to obtain a predefined value/password for Installer Menu item 117 FACT DEFAULT that enables access to initiate a factory “IN-STOP” process, which restores all factory defaults on the STB. This procedure will also reactivate the EZ-Manager Wizard.

1. Use the Installer Remote to access the STB’s Installer Menu.
2. Navigate to Installer Menu item 117 FACT DEFAULT, and key in the value provided by technical support. Then, press **OK**.
3. At the prompt for confirmation, key in the password provided by technical support. This will initiate the IN-STOP that restores the factory defaults on the STB.

Installer Menu Item 117 FACT DEFAULT

If the STB is currently in Pass-through Mode, you can set Installer Menu item 117 FACT DEFAULT to 1 to restore the Installer Menu factory defaults and clear the PTC Channel Map, including any assigned channel icons and custom text labels. Note, however, that if a complete restoration of the STB’s factory defaults is required, see “Restore All Factory Defaults” above.

Additional FTG Mode Options

There are two additional options for restoring Pass-through Mode/Installer Menu factory defaults on STBs that are in FTG Mode. The first enables you to restore a single STB to Pass-through Mode, while the second enables you to restore multiple STBs to Pass-through Mode at one time. However, both options require that you create a “Restore_Pass-through_Mode.tlx” file, i.e., an FTG Configuration file with no data. Refer to the **Cloud Configuration Tool User Guide** for further information.

- Using a USB memory device, import a “Restore_Pass-through_Mode.tlx” file to the STB. Refer to “Importing a Clone File” on pages 69 to 73 for further information on the import procedure.
- If your system uses a Pro:Centric server for remote management of STB-6500s that are in FTG Mode, use the Pro:Centric Admin Client to load a “Restore_Pass-through_Mode.tlx” file on the Pro:Centric server. Refer to the **Pro:Centric Server Admin Client User Guide** for further information.

Reference: Using the STB's Zoning Features

This section describes the STB Zoning and Wi-Fi Zoning features available with the STB-6500. These features are primarily intended for use when the STB is configured for FTG Mode operation; however, Wi-Fi Zoning, along with selected elements of STB Zoning (Installer Menu and Setup Menu profile Zone assignments), may also be used with STB cloning processes using a Clone (.tlx) file. Refer to the appropriate section(s) below for further information on the Zoning features and how to set the STB Zone # and/or Wi-Fi Zone # in an STB that is currently in Pass-through Mode.

STB Zoning Feature

This feature enables you to create localized configurations for STBs/displays in selected “Zones” within the installation site, for example, a hotel lobby, fitness center, restaurant, etc.

Using the STB Zoning Feature with FTG Mode Configuration

The Cloud Configuration Tool may be used to create an FTG Configuration (.tlx) file that contains multiple Installer Menu and Setup Menu profiles, each with its own Zone assignment. Up to nine unique Zones can be designated for STB-6500 FTG Installer Menu and/or Setup Menu profiles. Zone restrictions can also be placed on individual channels in the FTG Channel Map. Thus, for example, you may create an FTG Installer Menu and/or Setup Menu profile to uniquely configure an STB/display in the hotel lobby and also restrict the channels that are available to be tuned on that STB/display.

The STB Zone # must be set appropriately on each STB in order for the STBs to be configured correctly. See “Set the STB Zone # and/or Wi-Fi Zone # in the STB” on page 117, and set the STB Zone # in all the STBs in a select area, so that the STBs/displays are configured with corresponding FTG Installer Menu and/or Setup Menu settings and/or can omit channels that have been restricted in the FTG Channel Map. STB Zone 0 is the default STB Zone #.

The following subsections briefly describe how to assign Zones in the Cloud Configuration Tool. Refer to the **Cloud Configuration Tool User Guide** for further information.

FTG Installer Menu Profile Zone Assignments

The Cloud Configuration Tool / Installer Menu web page enables you to create multiple Installer Menu profiles for the same chassis model, each with a different Zone assignment (default = Zone 0) to be included in an FTG Configuration (.tlx) file. For example, you may wish to create one Installer Menu profile for the STB-6500 in the hotel lobby and another Installer Menu profile for the STB-6500 in the fitness center, both of which are different from the Installer Menu profile used for the STB-6500 in standard guest rooms. The STB Zoning feature enables you to save multiple STB-6500 FTG Installer Menu profiles, each with its own Zone assignment, in one FTG Configuration file. If each STB in the aforementioned locations (Zones) has had its STB Zone # set appropriately, as described in the procedure on page 117 or via the Solution Settings / EZ-Manager Wizard, the STB(s) will only be configured by the Installer Menu profile that matches its(their) Zone setting.

In the Cloud Configuration Tool / File Manager web page, you can also change the Zone assignment for each Setup Menu profile already present in the FTG Configuration List. See the File Manager and Installer Menu web page overviews on pages 78 and 80 for further information. Note that Setup Menu profiles cannot be created in the Cloud Configuration Tool; they must be saved (exported) from a TV/STB.

Reference: Using the STB's Zoning Features (Cont.)

FTG Channel Map Zone Restrictions

In the Cloud Configuration Tool / Channel Map web page, you can place Zone restrictions on individual channels that may be prohibited or deemed unsuitable for certain locations. One or more Zone restrictions (1–8) may be placed on each channel that is to be restricted. For example, if you wish to restrict a channel from Zones 2 and 4, select both “Zone 2” and “Zone 4” in the Restricted From Zones field when defining or editing that channel.

Note: While a channel can be restricted from up to eight Zones, an STB can only ever be in (set for) one Zone. See also the Channel Map web page overview on page 79.

At the same time, keep in mind that the STB Zone designations are not mutually exclusive. That is, you may opt to place Zone restrictions on selected channels in the FTG Channel Map, but at the same time, you can choose to configure all STBs/displays at the site with the same Installer Menu and/or Setup Menu settings. For example, an FTG Configuration (.tlx) file being used to configure the STBs/displays at a site may contain multiple Installer Menu and Setup Menu profiles with different Zone assignments, as well as an FTG Channel Map with Zone restrictions on several channels. Each STB that still has the default STB Zone 0 setting will *only* be configured by the Installer Menu and/or Setup Menu profile(s) with a Zone 0 designation. If, on the other hand, the STB Zone # is set to 1, the STB will first look in the file for the STB-6500 Installer Menu and/or Setup Menu profile(s) with a Zone 1 designation. If none of the STB-6500 Installer Menu and/or Setup Menu profiles has a Zone 1 designation, the STB will then look for the STB-6500 profile(s) with a Zone 0 designation. For the FTG Channel Map configuration, when the STB Zone # is set to 0, the STB will ignore any Zone restrictions (1–8) that may be placed on channels in the FTG Channel Map. However, when the STB Zone # is set to 1, the STB will omit any channels that have been restricted from Zone 1 in the FTG Channel Map.

Using the STB Zoning Feature with Cloning Configuration

A location-specific configuration / Clone (.tlx) file may be saved (exported) from a Master STB and then be used to configure Target STBs. For example, if the STB Zone # in the Master STB is set to 3 before the Clone file export is initiated, the Master STB's Installer Menu and Setup Menu profiles will be saved with the STB Zone 3 assignment. In order to configure the Target STBs with the Zone 3 Installer Menu and Setup Menu profiles exported from the Master STB, you must set the STB Zone # accordingly in the Target STBs before importing the Clone file. See “Set the STB Zone # and/or Wi-Fi Zone # in the STB” on the following page. Also, see “Cloning Procedures” on pages 67 to 73 for additional information on the cloning processes. STB Zone 0 is the default STB Zone #.

Wi-Fi Zoning Feature

This feature enables you to use a Clone/Configuration (.tlx) file to configure an individual STB or group of STBs with a particular Wi-Fi access point's login data to create “Wi-Fi Zones” within the installation environment.

Using the Wi-Fi Zoning Feature with FTG Mode Configuration

The Cloud Configuration Tool may be used to create an FTG Configuration (.tlx) file with an FTG Installer Menu profile that contains login data for multiple Wi-Fi access points, each assigned a Wi-Fi Zone #. Up to 100 Wi-Fi Zones can be designated within each FTG Installer Menu profile, thus allowing for distribution of the Wi-Fi network load. For example, if a site has 50 STB-6500s within close proximity, you may wish to create 10 Wi-Fi Zones, each with its own access point that has unique login data, so that no more than five of the STBs are connected to one access point at any given time.

Reference: Using the STB's Zoning Features (Cont.)

In order for an STB to be configured by the proper Installer Menu profile with the desired Wi-Fi access point login data for wireless networking (i.e., SSID, security type, and security key), you must set both the STB Zone # and the Wi-Fi Zone # in the STB (see “Set the STB Zone # and/or Wi-Fi Zone # in the STB” below for further information). If the Wi-Fi Zone # in the STB is set to 0 (default), the STB will not obtain access point login data from the Installer Menu profile with which it is configured unless the profile contains the global Wi-Fi Zone 100. Any STB that does not find its matching Wi-Fi Zone # in the FTG Configuration file, but that does find the global Wi-Fi Zone 100, will be configured with the global access point login data.

Refer to the **Cloud Configuration Tool User Guide** for further information on defining Wi-Fi Zones in the Cloud Configuration Tool.

Using the Wi-Fi Zoning Feature with Cloning Configuration

A location-specific Wi-Fi configuration / Clone (.tlx) file may be saved (exported) from a Master STB and then be used to configure Target STBs. First, the wireless network (i.e., the access point login data) must be configured in the Master STB's IP Environment Menu (see “Configuring a Wi-Fi Network Connection” on pages 83 to 84). Then, a Wi-Fi Zone # must be set in the Master STB (see “Set the STB Zone # and/or Wi-Fi Zone # in the STB” below). If desired, an STB Zone # may also be set in the Master STB.

For example, if the Wi-Fi Zone # is set to 4 and the STB Zone # is set to 5 before the Clone file export is initiated, the Master STB's Installer Menu profile will be saved with the Zone 5 assignment, and within that Installer Menu profile, the access point login data for wireless networking (i.e., SSID, security type, and security key) will be saved with a Wi-Fi Zone 4 assignment. In order to configure the Target STBs with the proper Installer Menu profile and access point login data, you must set both the STB Zone # and the Wi-Fi Zone # in the Target STBs accordingly before importing the Clone file. See “Set the STB Zone # and/or Wi-Fi Zone # in the STB” below. Also, see “Cloning Procedures” on pages 67 to 73 for additional information on the cloning processes. If the Wi-Fi Zone # in the STB is set to 0 (default), the STB will not obtain access point login data from the Installer Menu profile with which it is configured unless the profile contains the global Wi-Fi Zone 100. Any STB that does not find its matching Wi-Fi Zone # in the Clone file, but that does find the global Wi-Fi Zone 100, will be configured with the global access point login data.

Set the STB Zone # and/or Wi-Fi Zone # in the STB

You can set the STB Zone # and/or the Wi-Fi Zone # in the Solution Settings / EZ-Manager Wizard (see “Solution Settings / EZ-Manager Wizard” on pages 32 to 44) or, if the STB is in Pass-through Mode, via the STB's setup menus as described below. Note that the following procedure can only be performed while the STB is in Pass-through Mode. You will also be able to specify a Label (North, South, East, West) and Room Number for this STB, if desired.

1. Turn ON the STB/display panel.
2. Press **MENU** on the Installer Remote, and use the arrow navigation keys to select/highlight the **General** menu icon. Then, press **OK**.
3. In the General Menu, use the Up/Down arrow keys to select **Room Info**, and then press **OK**.
4. In the Room Info screen, complete the appropriate fields as described below. Use the Up/Down arrow keys on the Installer Remote to navigate between each of the fields.

(Continued on next page)

Reference: Using the STB's Zoning Features (Cont.)

(Continued from previous page)

- **Wi-Fi Zone:** Enables you to set a Wi-Fi Zone # so that the STB can be configured with a particular access point's login data for wireless networking. Login data (i.e., SSID, security type, and security key) may be provided in a Clone/Configuration (.tlx) file.
To assign a Wi-Fi Zone, select/highlight the **Wi-Fi Zone** field and press **OK**. Then, use the Left/Right arrow keys to specify the desired Wi-Fi Zone # (1–99). Press **OK** when you are finished.
- **STB Zone:** Enables you to set a STB Zone # so that the STB can be configured with Installer Menu and/or Setup Menu settings intended only for the assigned Zone. The Installer Menu and/or Setup Menu settings may be provided in a Clone/Configuration (.tlx) file. If the STB is being configured for FTG Mode, the STB Zone # setting also allows the STB to omit channels that have been restricted in the FTG Channel Map (see “FTG Channel Map Zone Restrictions” on page 116).
To change the STB Zone, select/highlight the **STB Zone** field and press **OK**. Then, use the Left/Right arrow keys to specify the desired STB Zone # (0–8). Press **OK** when you are finished.
- **Label:** Allows you to select a North, South, East, or West text label for this STB. Select/highlight the **Label** field and press **OK**. Then, use the Up/Down arrow keys to select the applicable label. Press **OK** when you are finished.
- **Room Number:** Allows you to specify the number of the room—up to 16 characters—in which the STB is located. To enter a room number, use the Up/Down arrow keys to select/highlight the **Room Number** field and press **OK**. You can then use the number keys on the Installer Remote to direct enter a room number, or you can use the arrow keys to select the appropriate alphanumeric character(s) from the pop-up virtual keyboard at the bottom of the screen. When you are done, select **Enter** from the virtual keyboard, and then press **OK** on the Installer Remote.

Note: The STB name (default: “[LG] webOS STB”) will be changed to the room number specified here. See “Media Share Setup” on pages 95 to 98 for further information on the STB name.

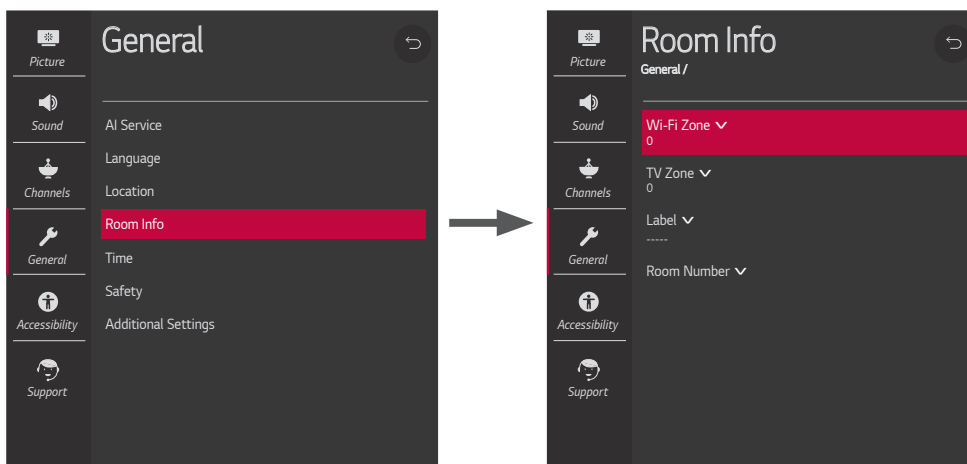

5. When you have completed the fields as necessary, press **↵** to return to and/or exit the STB menus, or press **MENU** to return to program viewing.

When the appropriate Media Share options are enabled in the IP Environment / Media Share Menu, end users have the ability to use one or more of the Media Share features. See also “Media Share Setup” on pages 95 to 98.

This section provides an overview of the Smart Share, Screen Share, DIAL, and SoftAP functionality.



Note: Typically, only one Media Share feature may be used at a time. If one feature is currently in use, you may have to exit or turn it off in order to use/turn on another. In some cases, you will be prompted to confirm your action. Follow the display prompts as necessary.

Smart Share (DLNA Certified Devices)

The following steps describe how to access and use the Smart Share feature with DLNA Certified devices on the same LAN as the STB.

1. Turn ON the STB/display panel, and then use one of the following methods to access media files/folders, depending on the current configuration of the STB:
 - If the Pro:Centric application is not loaded, press **PORTAL** on the Installer Remote, and use the Left/Right arrow keys to select **Music** or **Photo & Video** from the STB’s Smart Launcher.
 - If the Pro:Centric application is loaded, press **MENU** on the Installer Remote to display the Function Menu, use the Up/Down arrow keys to select/highlight the **General** menu icon, and then press **OK**. In the General Menu, use the Up/Down arrow keys to select **Music** or **Photo & Video**.

Note: Depending on the remote control being used (in any mode), you may also access the Smart Launcher via the SMART key.

2. In the next screen (Music or Photo & Video, depending on your selection in the previous step), select the desired Smart Share device, and then select the desired file(s) to view.

Screen Share (Miracast / WiDi)

The following steps describe how to access and use the Screen Share feature to select a Miracast or WiDi capable device, whose screen can be displayed on the display panel screen.

1. Turn ON the STB/display panel, and then use one of the following methods to access Screen Share, depending on the current configuration of the STB:
 - If the Pro:Centric application is not loaded, press **PORTAL** on the Installer Remote, and use the Left/Right arrow keys to select **Screen Share** from the STB’s Smart Launcher.
 - If the Pro:Centric application is loaded, press **MENU** on the Installer Remote to display the Function Menu, use the Up/Down arrow keys to select/highlight the **General** menu icon, and then press **OK**. In the General Menu, use the Up/Down arrow keys to select **Screen Share**.

Note: If Screen Share is currently not available/accessible in the Smart Launcher or Function Menu, you may need to exit/turn off another Media Share feature in order to use Screen Share. For example, select **Wi-Fi Service** (SoftAP) in the STB’s Smart Launcher, and make sure that SoftAP is turned off. See also note above regarding simultaneous use of Media Share features.

Note: Depending on the remote control being used (in any mode), you may also access the Smart Launcher via the SMART key.

(Continued on next page)

Reference: Using Media Share Features (Cont.)

(Continued from previous page)

2. Follow the on-screen instructions to initiate the Miracast / WiDi connection from your Miracast / WiDi device. Note that you may be prompted to enter a PIN number that appears on the display panel screen into your Miracast / WiDi connection window to complete the connection.

Once the connection is established, the STB/display panel may be used as a second screen for the Miracast / WiDi device.

DIAL

The following steps describe how to access and use DIAL. Remember that the device used **MUST** be connected to the same network as the STB.

Note: DIAL may only be used with device applications for which a STB-compatible application (for example, YouTube) has been created/selected for inclusion in the Pre-loaded Apps Menu (see “Pre-loaded Applications” on page 94).

1. Turn ON the STB/display panel.
2. On your device, launch the desired application (see also note above, regarding the Pre-loaded Apps requirement), and use the appropriate options, typically available via Settings, to initiate a connection/pairing with the STB. You may also need to access the Settings options from the application on the STB to complete the pairing operation. Follow the on-screen instructions.

Once the connection/pairing is successful, you will be able to view media from the application on the display panel screen.

SoftAP

The following steps describe how to access and use the SoftAP (Wi-Fi Service) feature.

1. Turn ON the STB/display panel, and then use one of the following methods to access SoftAP, depending on the current configuration of the STB:
 - If the Pro:Centric application is not loaded, press **PORTAL** on the Installer Remote, and use the Left/Right arrow keys to select **Wi-Fi Service** from the STB’s Smart Launcher.
 - If the Pro:Centric application is loaded, press **MENU** on the Installer Remote to display the Function Menu, use the Up/Down arrow keys to select/highlight the **General** menu icon, and then press **OK**. In the General Menu, use the Up/Down arrow keys to select **SoftAP**.

Note: If SoftAP is not currently accessible, or if a message is displayed indicating that SoftAP (Wi-Fi Service) is not currently available, make sure a wired LAN connection to the STB has been established.

Note: Depending on the remote control being used (in any mode), you may also access the Smart Launcher via the SMART key.

2. When you initially access the SoftAP (Wi-Fi Service) screen, the Off/On toggle button at the top right of the screen is selected/highlighted by default. If it is currently off, press **OK** on the Installer Remote to turn on SoftAP (Wi-Fi Service). When SoftAP (Wi-Fi Service) is on, the SoftAP access information, including the SSID and security key, is displayed in the lower half of the screen.

(Continued on next page)

Reference: Using Media Share Features (Cont.)

(Continued from previous page)

3. Make sure Wi-Fi is turned on on your device, and then use the access information provided to initiate a connection to the STB's network.

Once a device is connected successfully to the STB's network, you can use it to access the Internet. Up to 10 devices may be connected at a time, though excessive use by some devices may diminish the performance of other devices and/or cause them to disconnect.

Note: A wired network connection MUST be established in order for end users to use SoftAP/Wi-Fi Service. Also, the SoftAP/Wi-Fi Service feature may only be used while the STB/display panel is turned ON.

Note: SoftAP supports both 2.4 GHz and 5 GHz Wi-Fi frequencies. If you are having difficulty with one Wi-Fi frequency, try the other.

Reference: STB-6500 Jack Panels

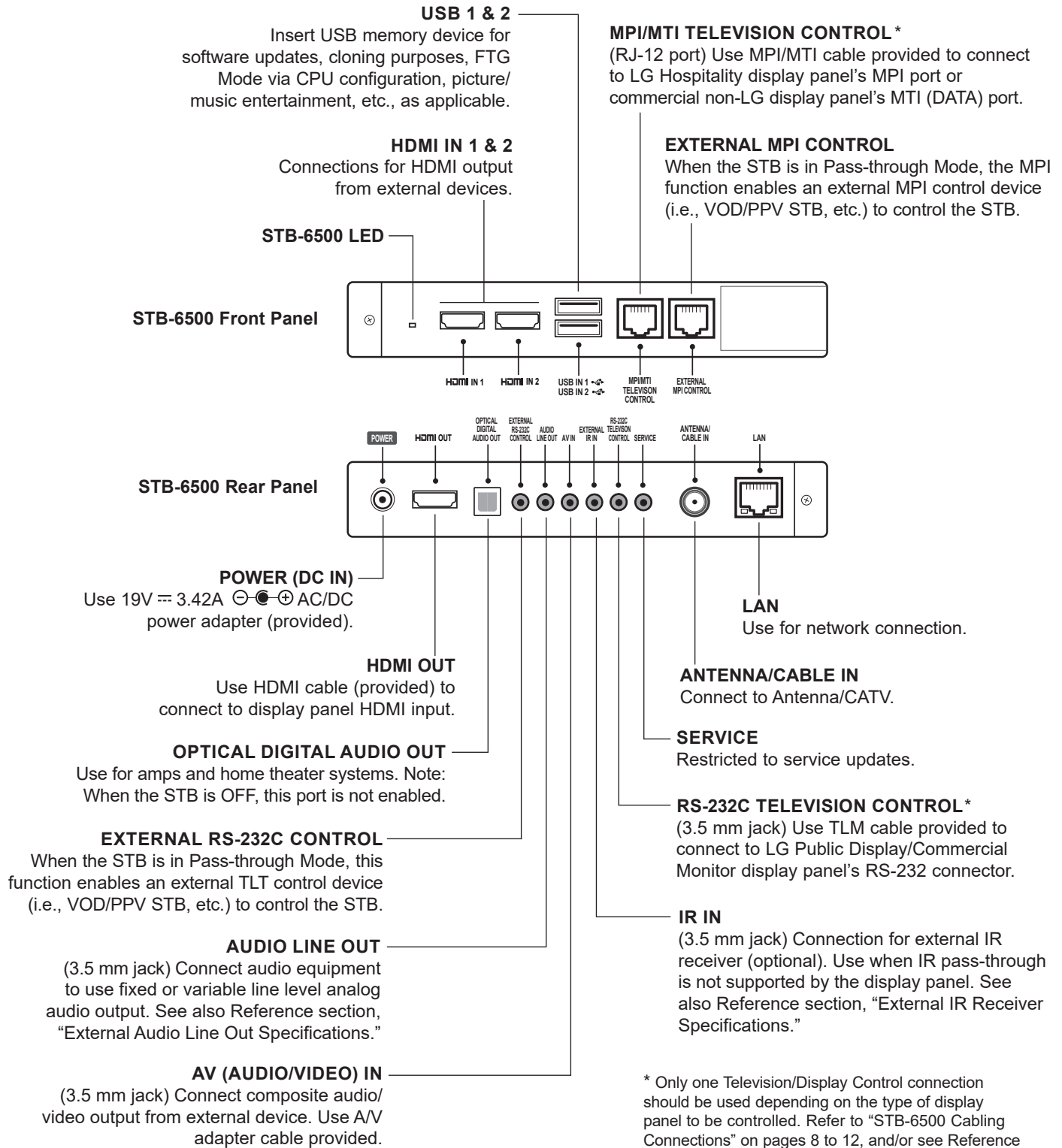

Reference: External IR Receiver Specifications

The IR IN 3.5 mm stereo jack on the rear panel of the STB-6500 provides an input for an optional external IR receiver. The jack provides 3.5 volts power for an external receiver. Refer to the following diagram for pinout details.

 **Caution: Do NOT insert a mono plug, as this may damage the STB.**

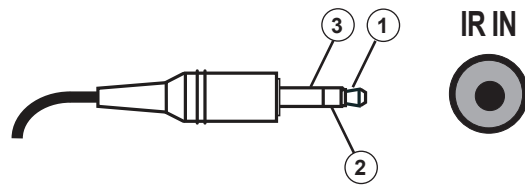

Contact	Description
+3.5 v (Power for IR Receiver)	Connects to 1 (Tip)
IR Data In (Electrical Signal from IR Receiver*)	Connects to 2 (Ring)
GND	Connects to 3 (Sleeve)

* Normally high signal with logic low pulses.

Reference: External Audio Line Out Specifications

The AUDIO LINE OUT 3.5 mm stereo jack on the rear panel of the STB-6500 provides stereo analog audio output for external audio equipment. Installer Menu item 097 AUDIO OUTPUT must be set to either 9 or 10 to make analog audio output available. See Installer Menu item 097 AUDIO OUTPUT description on page 60 for additional information. Also, refer to the following diagram for pinout details.

⚠ Caution: Do NOT insert a mono plug, as this may damage the STB.

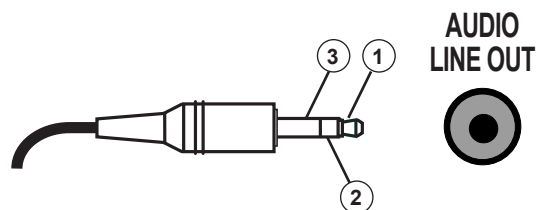

-
- | | |
|---|--------------|
| 1 | LEFT (Tip) |
| 2 | RIGHT (Ring) |
| 3 | GND (Sleeve) |
-

Reference: Installer Remote Control Typical Key Functions

An LG Installer Remote is required to set up and operate the STB/display panel. The LG Installer Remote illustrated below shows typical remote control functions and is provided for reference only.

⏻ (POWER)
Turns the STB/display ON or OFF

SMART
Displays the STB's Smart Launcher.

TV DVD INPUT TIMER
Select the remote's operating mode: TV or DVD.

INPUT
Displays available Aux inputs.

TIMER
Sets the amount of time before the STB automatically turns itself OFF.

Numbers (0 - 9) & DASH
Use to enter a channel or channel and program number. Dash is keyed in between channel number and program number to enter digital channels, such as 2-1, 2-2, etc.

FLASHBK (FLASHBACK)
Returns to the previously tuned channel or input.

VOLUME UP/DOWN
Increases/decreases sound level.

CC
Displays Closed Caption options. Closed Caption availability varies by program.

VD/*
Enables VD function. Also enables SAP feature (displays Multi Audio or Audio Language options, i.e., additional audio content/languages, if available). *

MUTE
Switches sound ON or OFF.

CHANNEL/PAGE UP/DOWN
Changes channels based on channels in the channel lineup. Moves to previous or next screen in Pro:Centric channel guide.

Color buttons access special functions in some menus.

DVD/USB buttons
Use to control DVD player or view USB memory device content.

IMPLINK, PIP, PIP CH +/-, PIP INPUT, SWAP, and 3D are N/A for this STB model.

Arrows (Up/Down/Left/Right) & OK
Use to navigate on-screen menus, direct tune channels, and adjust STB settings.

MENU SETTINGS
Displays and removes the STB setup menu (or, if applicable, the Function Menu).

PORTAL
Displays and removes the Pro:Centric interactive menu.

INFO
Displays channel information.

GUIDE
Displays and removes the Pro:Centric channel guide/EPG.

↶ (RETURN)
Returns one level to the previous menu/display.

EXIT
Clears all on-screen displays and returns to program viewing.

*** SAP notes:**

- If SAP is selected and no SAP is provided, sound may not be heard on channel.
- Each channel may have its own SAP setting.
- Each time digital channels are tuned, the STB attempts to locate the default audio program language. If the default audio program language is not available, the STB will use the first available audio program.

Reference: LG Slate-RX Lodging Remote

If you are using an LG display panel, the LG remote provided with the display panel should be sufficient. However, if you are using a commercial non-LG display panel or if you intend to use multiple STBs/displays in a single room installation environment, a Slate-RX remote control (SKU: HOSPSTRCSR1) is available from LG. See example at right. A version of this remote also is available with a NETFLIX® key in place of the SMART key (SKU: HOSPSTRCSN2).*

For additional information and/or to purchase a Slate-RX remote, please contact your LG Sales representative or distributor.

Installer Remote Functionality

LG Slate-RX remote controls provide the same standard configuration functionality as a typical LG Installer Remote, along with multi-code capability. See also “Installer Remote Control Typical Key Functions” information on the previous page.

LG Multi-code Functionality

LG Slate-RX remote controls send unique LG IR codes based on “bed number” (Bed 1 to Bed 16) in a multi-STB/display single room installation.

Note: The STB will always respond to the standard LG Installer Remote IR code scheme, i.e., you can always use an LG TV Installer Remote with the STB, regardless of its multi-code IR setting.

The following procedure describes how to set the bed number in the STB’s Installer Menu and in the remote control.

1. Access the STB Installer Menu, and set item 020 FEATURE LEVEL to the desired value 16–31 (Bed 1–Bed 16).

The Slate-RX remote control must now be set to match the STB’s setting. That is, if item 020 is set to 17 for Bed 2, the remote must also be set to multi-code Bed 2.

Note: By default, the Slate-RX remote IR code scheme is the same as the standard LG TV Installer Remote IR code scheme.

2. On the remote, press and hold the **INPUT** key until the LED on the remote blink twice (about five seconds).
3. Press the **1** key on the remote to enter programming mode.
4. Use the number keys on the remote to key in the five-digit code for the desired LG Bed number—refer to the table on the following page for bed codes.

After a valid code is entered, the remote LED will blink rapidly two times to indicate the setup is complete.

5. Verify that the remote now controls the STB/display, based on your settings.

Note: If necessary, you can restore the Slate-RX remote IR code scheme to the standard LG Installer Remote IR code scheme by repeating steps 1 to 4 above using Bed “0” (code: 00000).



* This example shows typical remote control functions and is provided for reference only.

Reference: LG Slate-RX Lodging Remote (Cont.)

Bed #	Code	Bed #	Code
LG Bed 1	00001	LG Bed 9	00009
LG Bed 2	00002	LG Bed 10	00010
LG Bed 3	00003	LG Bed 11	00011
LG Bed 4	00004	LG Bed 12	00012
LG Bed 5	00005	LG Bed 13	00013
LG Bed 6	00006	LG Bed 14	00014
LG Bed 7	00007	LG Bed 15	00015
LG Bed 8	00008	LG Bed 16	00016

Reference: TLT Communication Parameters

Based on the setting of Installer Menu item 030 EXTCTL/ACKMASK, you may use the STB's RS-232C port for TLT communication purposes.

RS-232C Configuration

**EXTERNAL RS232C CONTROL
3.5 mm Jack on STB**

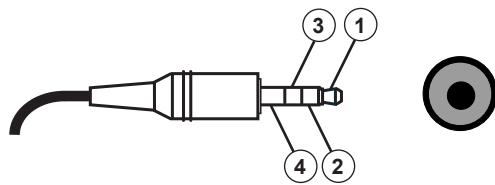

**EXTERNAL RS232C CONTROL Jack
4 Contact Configuration**

Contact	Description
TXD	Connects to 1 (Tip)
RXD	Connects to 2 (Ring 1)
IR Data Pass-through *	Connects to 3 (Ring 2)
GND	Connects to 4 (Sleeve)

* Normally low signal with logic high pulses.

Communication Parameters

- Baud rate: 9600 bps (UART)
- Parity: None
- Data length: 8 bits
- Stop bit: 1 bit

Command Reference List

Note: Commands may work differently depending on model and signal.

	Command 1	Command 2	Data (Hexadecimal)		Command 1	Command 2	Data (Hexadecimal)
01. Power	k	a	00 / 01	12. Remote Control Lock Mode	k	m	00 / 01
02. Aspect Ratio	k	c	(see page 130)	13. Balance **	k	t	00–64
03. Screen Mute	k	d	00, 01, 10	14. Color Temperature *	x	u	00–64
04. Volume Mute	k	e	00 / 01	15. Equalizer	j	v	(see page 132)
05. Volume Control	k	f	00–64	16. Tune Command	m	a	(see page 132)
06. Contrast *	k	g	00–64	17. Channel Add/Delete	m	b	00 / 01
07. Brightness *	k	h	00–64	18. Key	m	c	(see page 133)
08. Color *	k	i	00–64	19. Control Backlight	m	g	00–64
09. Tint *	k	j	00–64	20. Input Select (Main)	x	b	(see page 133)
10. Sharpness *	k	k	00–32	21. Channel Block/Unblock	m	d	(see page 134)
11. OSD Select	k	l	00 / 01				

* These features are also adjustable in the Picture Menu.

** This feature is also adjustable in the Sound Menu.

Reference: TLT Communication Parameters (Cont.)

Transmitting / Receiving Protocol

This communication protocol transmits and receives 1-byte ASCII data representation for each Command, Set ID, and Data character. Therefore, a standard ASCII terminal program can be used to send and receive the protocol.

Command Structure

[Command1][Command2][][Set ID][][Data][CR]

The following table describes the parameters.

[Command 1]	First part of command to control the TV: j, k, m, or x. Corresponding transmission data of 0x6A, 0x6B, 0x6D, or 0x78, respectively.
[Command 2]	Second part of command to control the TV.
[Set ID]	Choose the [Set ID] value to match the Set ID number in the General Menu. The Set ID valid range is decimal 1 to 99. If the [Set ID] value is sent as [00], every connected display will act on the command. Note: The [Set ID] value should be entered in an ASCII terminal program as hexadecimal 00 to 63 values; however, note that each character of the hexadecimal value is transmitted as the ASCII value of that character. For example: [00] since ASCII 0=0x30, would be sent as "3030" [0A] since ASCII A=0x41, would be sent as "3041" [63] since ASCII 6=0x36 & ASCII 3=0x33, would be sent as "3633"
[Data]	Enter the command's required data (hexadecimal—see [Set ID] note above for correct translation). Enter Data [FF] to read status of the function.
[CR]	Carriage Return (ASCII value 0x0D)
[]	Space (ASCII value 0x20)

OK Acknowledgment

[Command2][][Set ID][][OK][Data][x]

The display responds with OK acknowledgment in the format shown above after receiving valid Command and Data values. The lowercase [Data] value in the response is either the current status (if Data [FF] was sent) or the [Data] value, regardless of case, that was sent in the acknowledged control command.

Error Acknowledgment

[Command2][][Set ID][][NG][Data][x]

The display responds with NG (error) acknowledgment in the format shown above after receiving abnormal data from non-viable functions or communication errors. The lowercase [Data] value in the response is the [Data] value, regardless of case, that was sent in the acknowledged control command.

Reference: TLT Communication Parameters (Cont.)

Data Conversion (Hexadecimal : Decimal)

In cases where decimal values are shown in commands, refer to following conversion examples to enter the [Data] value in the terminal program as hexadecimal.

Note: The Channel Tune (ma) Command uses two-byte hexadecimal values ([Data]) to represent the channel number.

00: Step 0	32: Step 50 or Set ID 50	FE: Step 254
01: Step 1 or Set ID 1	33: Step 51 or Set ID 51	FF: Step 255
...
0A: Step 10 or Set ID 10	63: Step 99 or Set ID 99	01 00: Channel 256
...
0F: Step 15 or Set ID 15	C7: Step 199	27 0E: Channel 9998
10: Step 16 or Set ID 16	C8: Step 200	27 0F: Channel 9999
...

TLT Command Detailed Descriptions

Note: Commands may work differently depending on model and signal.

01. Power (Command: k a)

- To control TV power (ON/OFF).

Command (Control) Structure

```
[k][a][ ][Set ID][ ][Data][CR]
```

[Data] Values:

00: Power Off

01: Power On

Acknowledgment

```
[a][ ][Set ID][ ][OK/NG][Data][x]
```

- To show TV power status (ON/OFF).

Command (Status) Structure*

```
[k][a][ ][Set ID][ ][FF][Cr]
```

Acknowledgment

```
[a][ ][Set ID][ ][OK][Data][x]
```

* Similarly, when Data [FF] is sent for other functions (based on this format), the Acknowledgment feedback returns status about each function.

02. Aspect Ratio (Command: k c)

To adjust the aspect ratio.

Command Structure

```
[k][c][ ][Set ID][ ][Data][CR]
```

[Data] Values:

01: Normal Screen (4:3)

02: Wide Screen(16:9)

04: Zoom

06: Set by Program/Original

09: Just Scan

10 to 1F: Cinema Zoom 1 to 16

0C: Cinemascope (21:9)

Acknowledgment

```
[c][ ][Set ID][ ][OK/NG][Data][x]
```

- Using the PC input, you can select either 16:9 or 4:3 screen aspect ratio.
- In DTV/HDMI/Component mode (high-definition), Just Scan is available.
- Full wide mode may work differently based on model and is supported for DTV fully and ATV / AV partially.

03. Screen Mute (Command: k d)

To control screen mute.

Command Structure

```
[k][d][ ][Set ID][ ][Data][CR]
```

[Data] Values:

00: Screen Mute Off (Picture On)

Video Mute Off

01: Screen Mute On (Picture Off)

10: Video Mute On*

Acknowledgment

```
[d][ ][Set ID][ ][OK/NG][Data][x]
```

* In case of Video Mute On only, the TV will show OSD. In case of Screen Mute On, the TV will not show OSD.

Reference: TLT Communication Parameters (Cont.)

04. Volume Mute (Command: k e)

To control volume mute.

Command Structure

```
[k][e][ ][Set ID][ ][Data][CR]
```

[Data] Values:

00: Volume Mute On (Volume Off)

01: Volume Mute Off (Volume On)

Acknowledgment

```
[e][ ][Set ID][ ][OK/NG][Data][x]
```

05. Volume Control (Command: k f)

To adjust volume.

Command Structure

```
[k][f][ ][Set ID][ ][Data][CR]
```

[Data] Values:

00 (minimum) to 64 (maximum)

Acknowledgment

```
[f][ ][Set ID][ ][OK/NG][Data][x]
```

06. Contrast (Command: k g)

To adjust screen contrast.

Command Structure

```
[k][g][ ][Set ID][ ][Data][CR]
```

[Data] Values:

00 (minimum) to 64 (maximum)

Acknowledgment

```
[g][ ][Set ID][ ][OK/NG][Data][x]
```

07. Brightness (Command: k h)

To adjust screen brightness.

Command Structure

```
[k][h][ ][Set ID][ ][Data][CR]
```

[Data] Values:

00 (minimum) to 64 (maximum)

Acknowledgment

```
[h][ ][Set ID][ ][OK/NG][Data][x]
```

08. Color (Command: k i)

To adjust the screen color.

Command Structure

```
[k][i][ ][Set ID][ ][Data][CR]
```

[Data] Values:

00 (minimum) to 64 (maximum)

Acknowledgment

```
[i][ ][Set ID][ ][OK/NG][Data][x]
```

09. Tint (Command: k j)

To adjust the screen tint.

Command Structure

```
[k][j][ ][Set ID][ ][Data][CR]
```

[Data] Values:

00 (Red) to 64 (Green)

Acknowledgment

```
[j][ ][Set ID][ ][OK/NG][Data][x]
```

10. Sharpness (Command: k k)

To adjust the screen sharpness.

Command Structure

```
[k][k][ ][Set ID][ ][Data][CR]
```

[Data] Values:

00 (minimum) to 32 (maximum)

Acknowledgment

```
[k][ ][Set ID][ ][OK/NG][Data][x]
```

11. OSD Select (Command: k l)

To select OSD (On Screen Display) status when controlling remotely.

Command Structure

```
[k][l][ ][Set ID][ ][Data][CR]
```

[Data] Values:

00: OSD Off

01: OSD On

Acknowledgment

```
[l][ ][Set ID][ ][OK/NG][Data][x]
```

12. Remote Control Lock Mode (Command: k m)

To lock both the display panel button functions and remote control IR features.

Command Structure

```
[k][m][ ][Set ID][ ][Data][CR]
```

[Data] Values:

00: Lock Off

01: Lock On

Reference: TLT Communication Parameters (Cont.)

Acknowledgment

[m][][Set ID][][OK/NG][Data][x]

- If the TV is turned OFF by Off timer or “ka” or “mc” command) while Remote Control Lock Mode is on, it is not possible to turn the TV back ON via the POWER key on the display panel or the remote control.
- When the TV’s AC power is removed/disconnected and then reapplied, Remote Control Lock is released.

13. Balance (Command: k t)

To adjust sound balance.

Command Structure

[k][t][][Set ID][][Data][CR]

[Data] Values:
00 (minimum) to 64 (maximum)

Acknowledgment

[t][][Set ID][][OK/NG][Data][x]

14. Color Temperature (Command: x u)

To adjust color temperature.

Command Structure

[x][u][][Set ID][][Data][CR]

[Data] Values:
00 (minimum) to 64 (maximum)

Acknowledgment

[u][][Set ID][][OK/NG][Data][x]

15. Equalizer (Command: j v)

To adjust EQ of the TV.

Command Structure

[j][v][][Set ID][][Data][CR]

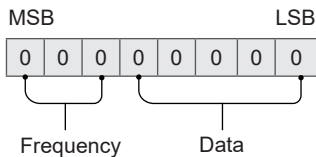

7	6	5	Frequency	4	3	2	1	0	Step
0	0	0	1st Band	0	0	0	0	0	0 (decimal)
0	0	1	2nd Band	0	0	0	0	1	1 (decimal)
0	1	0	3rd Band	-	-	-	-	-	-
0	1	1	4th Band	1	0	0	1	1	19 (decimal)
1	0	0	5th Band	1	0	1	0	0	20 (decimal)

Acknowledgment

[v][][Set ID][][OK/NG][Data][x]

Depends on model and can be adjusted when sound mode is EQ adjustable value.

16. Tune Command (Command: m a)

To tune the channel to the following Physical Major/Minor Channel number.

Command Structure

[m][a][][Set ID][][Data0][][Data1][][Data2][][Data3][][Data4][][Data5][CR]

- Analog Antenna/Cable
 - [Data0]: Physical Channel number
 - Antenna (ATV): 02–45 (Decimal: 2–69)
 - Cable (CATV): 01–7D (Decimal: 1–125)
 - [Data1–4]: Major/Minor Channel number
 - Data1 & Data2: xx (Don’t care)
 - Data3 & Data4: xx (Don’t care)
 - [Data5]: Input Source (Analog)*
 - 00: Antenna (ATV)
 - 01: Cable (CATV)
- * Installer Menu items 003 BAND/AFC and 102 ATSC BAND select the tuning band(s) for the display. In order for the tune command to be executed, the Input Source value for Data5 must match each tuner’s tuning band setting.
- Digital Antenna/Cable
 - [Data0]: Physical Channel number**
 - Antenna (DTV): 02–45 (Decimal: 2–69)
 - Cable (CADTV): 01–87 (Decimal: 1–135)
 - ** When [Data5] is 22, 26, or 66 (see below), use 00 for [Data0].
 - [Data1][Data2]: Major Channel number
 - Data1: High byte channel data
 - Data2: Low byte channel data
 - 00 01–27 0F (Decimal: 1–9999)

Reference: TLT Communication Parameters (Cont.)

[Data3][Data4]: Minor Channel number

- Data3: High byte channel data
- Data4: Low byte channel data
00 00–03 E7 (Decimal: 0–999)

[Data5]: Input Source (Digital)[†]

- 02: Antenna (DTV), Use Physical Channel number
- 06: Cable (Auto^{††}) (CADTV), Use Physical Channel number
- 22: Antenna (DTV), Do not use Physical Channel number (see also [Data0] ** above)
- 26: Cable (Auto^{††}) (CADTV), Do not use Physical Channel number (see also [Data0] ** above)
- 46: Cable (Auto^{††}) (CADTV), Use Physical Major Channel number only (One Part Channel)
- 66: Cable (Auto^{††}) (CADTV), Use Major Channel number only (One Part Channel), Do not use Physical Channel number (see also [Data0] ** above)

[†] Installer Menu items 003 BAND/AFC and 102 ATSC BAND select the tuning band(s) for the display. In order for the tune command to be executed, the Input Source value for Data5 must match each tuner's tuning band setting.

^{††} Cable bands Cable Std - x3, Cable HRC - x4, and Cable IRC - x5 can also be used in [Data5] lower nibble.

Two bytes are available for each Major and Minor Channel number. The high byte is 00 unless the channel number exceeds 255.

Tune Command Examples:

Example 1: Tune to analog cable channel 35

Set ID = All = 00
Data0 = Channel Data is 35 = 23
Data1 & Data2 = No Major = 00 00
Data3 & Data4 = No Minor = 00 00
Data5 = Analog Cable = 01
Total = ma 00 23 00 00 00 00 01

Example 2: Tune to digital antenna channel 30-3

Set ID = All = 00
Data0 = Don't know Physical = 00
Data1 & Data2 = Major is 30 = 00 1E
Data3 & Data4 = Minor is 3 = 00 03
Data5 = Digital Antenna = 22
Total = ma 00 00 00 1E 00 03 22

Acknowledgment

```
[a][ ][Set ID][ ][OK][Data 0][Data1]
[Data2][Data3][Data4][Data5][x]
[a][ ][Set ID][ ][NG][Data0][x]
```

17. Channel Add/Delete (NTSC) (Command: m b)

To set the saved channel status.

Command Structure

```
[m][b][ ][Set ID][ ][Data][CR]
```

[Data] Values:

- 00: Delete
- 01: Add

Acknowledgment

```
[b][ ][Set ID][ ][OK/NG][Data][x]
```

18. Key (Command: m c)

To send IR remote key code.

Command Structure

```
[m][c][ ][Set ID][ ][Data][CR]
```

See Key Codes table on page 135 for [Data] values.

Acknowledgment

```
[c][ ][Set ID][ ][OK/NG][Data][x]
```

19. Control Backlight (Command: m g)

To control the backlight.

Command Structure

```
[m][g][ ][Set ID][ ][Data][CR]
```

[Data] Values:

- 00 (minimum) to 64 (maximum)

Acknowledgment

```
[g][ ][Set ID][ ][OK/NG][Data][x]
```

20. Input Select (Command: x b)

To select input source for main picture.*

Command Structure

```
[x][b][ ][Set ID][ ][Data][CR]
```

[Data] Values:

- | | |
|-------------------|-----------------|
| 00: DTV | 41: Component 2 |
| 01: CADTV | 60: RGB |
| 02: Satellite DTV | 90: HDMI 1 |
| 10: ATV | 91: HDMI 2 |
| 11: CATV | 92: HDMI 3 |
| 20: AV or AV 1 | 93: HDMI 4 |
| 21: AV 2 | |
| 40: Component 1 | |

Acknowledgment

```
[b][ ][Set ID][ ][OK/NG][Data][x]
```

* This function depends on model and signal.

Reference: TLT Communication Parameters (Cont.)

21. Channel Block/Unblock (Command: m d)

To select channel block or unblock status. *

Command Structure

```
[m][d][ ][Set ID][ ][Data0][ ][Data1][ ][Data2][ ][Data3][ ][Data4][ ][Data5][ ][Data6][CR]
```

[Data0]: Physical Channel number

- Antenna (DTV): 02–45 (Decimal: 2–69)
- Cable (CADTV): 01–87 (Decimal: 1–135)

[Data1][Data2]: Major Channel number

- Data1: High byte channel data
- Data2: Low byte channel data
00 00–27 0F (Decimal: 0–9999)

[Data3][Data4]: Minor Channel number

- Data3: High byte channel data
- Data4: Low byte channel data
00 00–03 E7 (Decimal: 0–999)

[Data5]: Input Source

- 02: Antenna (DTV)
- 06: Cable (CADTV)
- 0b: Cable DTV Plus

[Data6]: Block/Unblock

- 00: Unblock
- 01: Block

Block/Unblock Command Example:

Block Cable DTV channel 18-2

Set ID = 01

Data0 = Physical Channel number 18 = 12

Data1 & Data2 = Major Channel number 18 = 00 12

Data3 & Data4 = Minor Channel number 2 = 00 02

Data5 = Cable (CADTV) = 06

Data6 = Block = 01

Total = md 01 12 00 12 00 02 06 01

Acknowledgment









```
[d][ ][Set ID][ ][OK][Data0][Data1][Data2][Data3][Data4][Data5][Data6][x][d][ ][Set ID][ ][NG][Data0][x]
```

* This function depends on model and signal.

Reference: TLT Communication Parameters (Cont.)

Key Codes

The following table provides typical LG key codes. Some keys are not applicable to all models.

Code (Hexa)	Function	Code (Hexa)	Function
00	CH UP	C0	 (Green)
01	CH DOWN	C1	 (Red)
02	VOL UP	C2	 (Yellow)
03	VOL DOWN	C3	 (Blue)
06	> (Right Arrow)	8E	 (Fast Forward)
07	< (Left Arrow)	8F	 (Rewind)
40	^ (Up Arrow)	B0	 (Play)
41	v (Down Arrow)	B1	 (Stop)
08	POWER (toggle)	BA	 (Pause)
C4	POWER ON	AA	INFO
C5	POWER OFF	AB	GUIDE
09	MUTE	7C	SMART
10–19	Numbers (0–9)	7E	SIMPLINK
28	BACK	DC	3D
39	CC (Closed Caption)	60	PIP
43	MENU SETTINGS	61	PIP INPUT
44	OK/ENTER	63	PIP SWAP
0A	SAP	71	PIP CH UP
0B	INPUT	72	PIP CH DOWN
0C	PORTAL	79	ASPECT RATIO
0E	TIMER	91	VIDEO DESCRIPTION
1A	FLASHBACK	CE	HDMI 1
4C	DASH	CC	HDMI 2
5B	EXIT	E9	HDMI 3
D6	TV	DA	HDMI 4
5A	VIDEO 1	BF	COMPONENT 1
D0	VIDEO 2	D4	COMPONENT 2
D5	RGB		

Troubleshooting

General Troubleshooting (Some Quick and Easy Tips for Resolving Problems)

Installation

Symptom	Possible Cause(s)	Possible Solution(s)
Cannot direct enter channel number.	(STB in Pass-through Mode) Installer Menu item 028 CH. OVERRIDE is set to 0, i.e., disabled (recommended setting).	If Installer Menu item 028 CH. OVERRIDE is set to 0, only channels that are active in the STB's channel lineup can be selected. Set item 028 to 1 to allow access for direct keypad entry to all channels.
	(STB not in Pass-through Mode) The channel entered is not included in the applicable Channel Map.	Channel access is restricted to channels included in the applicable Channel Map, e.g., the FTG Channel Map if the STB is in FTG Mode or the Pro:Centric Direct Channel Map if the STB is in Application Tuning Mode with Pro:Centric Direct. If necessary, make changes to the Channel Map using the appropriate application/content editor.

Power

Symptom	Possible Cause(s)	Possible Solution(s)
No power.	See STB Quick Check flow chart on following page.	

Picture Reception and Sound

Symptom	Possible Cause(s)	Possible Solution(s)
No picture. * See also STB Quick Check flow chart on following page. ** See "STB Cabling Connections" on pages 8 to 12.	Display panel is turned OFF.*	<ul style="list-style-type: none"> Check the Television/Display Control cabling.** Check that the display panel is connected to its AC power source.
	Display panel is not receiving signal from STB or is not displaying STB content.*	<ul style="list-style-type: none"> Check the HDMI cabling.** If you are not using HDMI 1 on the display panel, make sure Installer Menu item 100 VIDEO INTERFAC is set correctly. (TLM or MTI connection only) Check that Installer Menu item 110 PANEL DELAY is set appropriately.
	Antenna/cable not connected.	Connect antenna/cable signal to STB.
	Encrypted program.	Try another channel.
	Wrong tuning band.	Adjust Installer Menu settings.
Normal picture, poor or no sound.	Audio muted.	Press MUTE or use Volume Up key to increase sound level.
	Broadcast problem.	Try a different channel.

Erratic Operation

Symptom	Possible Cause(s)	Possible Solution(s)
Installer Menu setup.	Wrong Installer Menu settings.	Adjust Installer Menu settings as required.

Installer Remote (not supplied with STB)

Symptom	Possible Cause(s)	Possible Solution(s)
Remote doesn't work.	Television/Display Control not connected properly.	Use appropriate Television/Display Control cable (provided) to connect the STB to the display panel. See "STB Cabling Connections."
	Remote not in TV Mode.	Use MODE key to select "TV"; puts remote into TV Mode.
	Not aimed at IR receiver.	Point remote at IR receiver on display panel.
	Remote too far from IR receiver or IR path is obstructed.	Move remote closer to IR receiver on display panel, darken room, and/or remove obstructions.
	MPI not connected.	If applicable, connect MPI cable to MPI device.
	Weak batteries.	Replace batteries.
	Wrong battery polarity.	Check that "+" and "-" match in battery compartment.
	Too much light in room.	Dim room light.
Wrong Installer Remote.	Requires compatible LG Installer Remote (see examples in this document). Contact your LG service representative.	

This flowchart assumes that you have installed the STB/display panel in accordance with the STB Cabling Connections procedure on pages 8 to 12 and a subsequent functionality and/or communication failure has occurred.

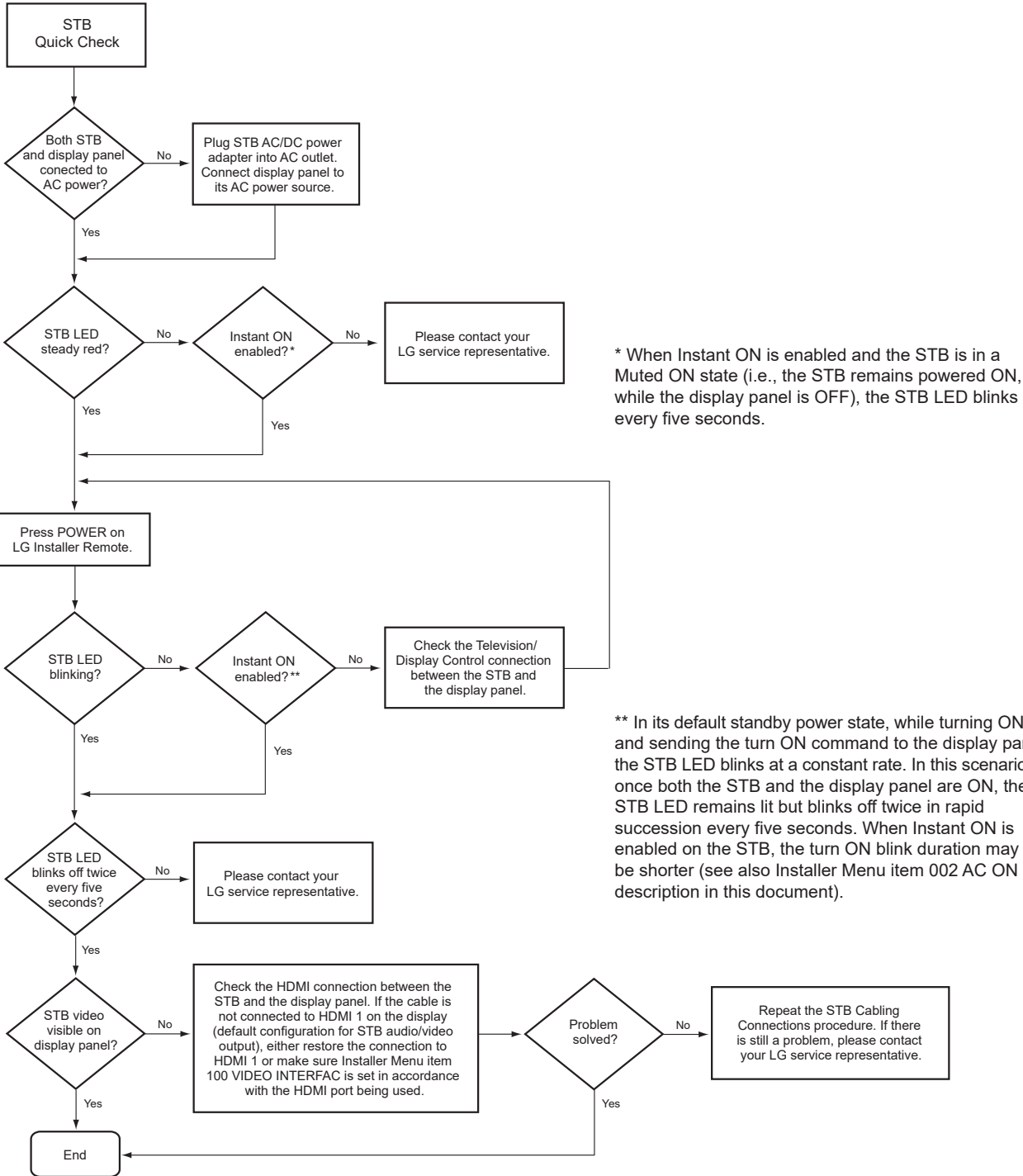

Troubleshooting (Cont.)

Commercial Mode Check

Use this flowchart to determine whether the STB is currently in Commercial Mode.

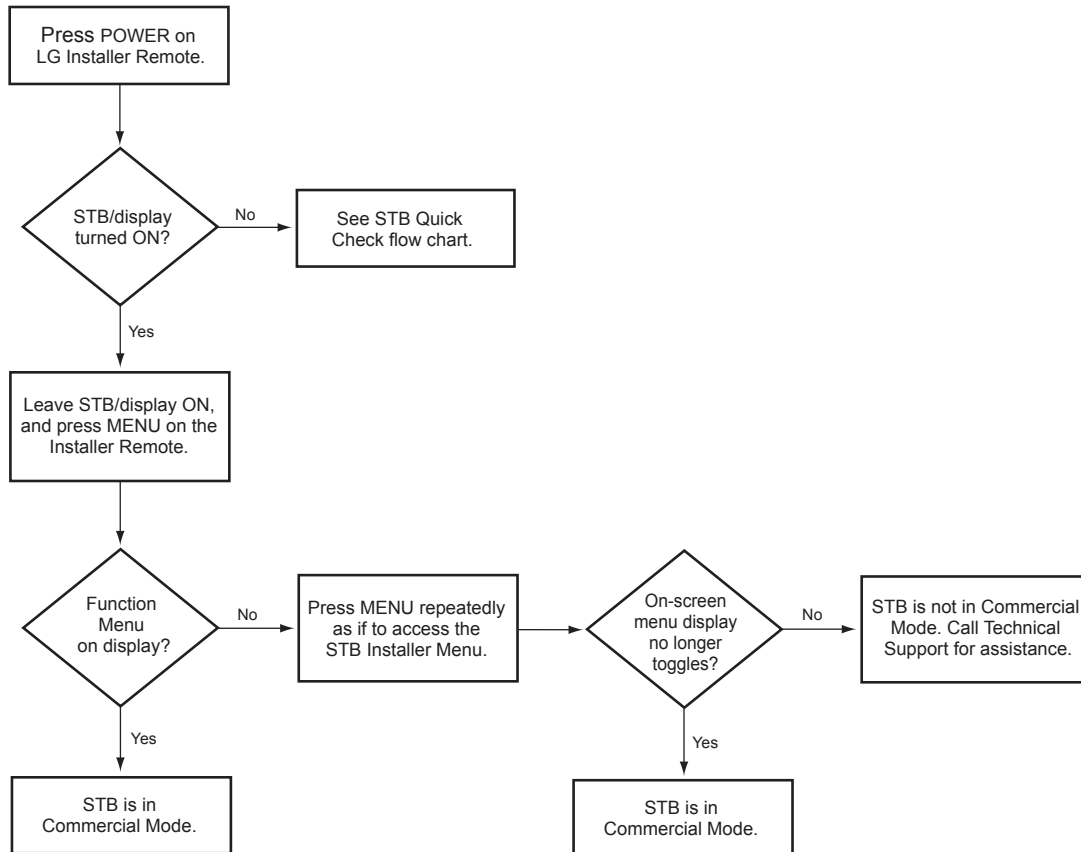

Application Tuning Mode

LG commercial TV mode that enables the TV's Channel Map to reside in a Pro:Centric application.

Basic Settings Wizard

Lodging model STB configuration wizard that provides basic settings options. Includes Channel Tuning.

Channel Lineup

Channels set in the STB memory, via Channel Tuning/manual editing.

Channel Map

Typically refers to a logical channel mapping of physical channels (for example, an FTG Channel Map). This allows digital channels, like analog channels, to be tuned without requiring the dash key. Also, channels (analog or digital) can be arranged in any order that seems logical for customer tuning/viewing.

Cloning

The process of capturing a Master STB Setup and transferring it to a Target STB using a USB memory device.

Commercial Mode

A mode of operation that provides a broad range of commercial STB features based on control (settings) provided by the PTC and/or an MPI control device.

CPU

The STB's Central Processing Unit. Responsible for the presentation of video and audio from content received via the STB's tuner or Aux inputs.

E-Z Installation

Enables STB configuration and software file downloads to selected STB models from a Pro:Centric server. Managed and administered via the appropriate Pro:Centric Admin Client.

EZ-Manager Wizard

Lodging model STB configuration wizard that provides configuration options for Pro:Centric operation as well as an option for using a USB memory device to configure an STB.

FTG Mode

LG commercial STB mode that enables decryption of Pro:Idiom encrypted channels and logical channel mapping. STBs may be configured locally using LG's proprietary PC software or remotely using an applicable head end device.

Function Menu

Available via Installer Remote "MENU" key. Indicates the STB is not in Pass-through Mode. Restricts menu options to a subset of the STB setup menus, allowing users to retain functional control, while disabling setup options.

Installer Menu

Defines commercial STB functionality based on the parameters set.

LG Free-To-Guest (FTG)

Refers to a particular commercial mode of operation within an LG STB. See also FTG Mode.

Logical Channel Number

A number assigned to either a physical or virtual channel number in a Logical Channel Map.

Major Channel Number

Typically, the RF channel number assigned to a digital video stream.

Master STB

An STB whose Channel Map and Installer Menu and STB setup menu settings have been configured as a Master STB Setup for cloning purposes.

Minor Channel Number

A sub-channel or program number assigned to the content embedded in the digital video stream.

MPI

Multiple Protocol Interface. An EXT MPI CONTROL port or, for some STB models, an MPI card slot provides external control options for solution providers.

MTI

Multiple Television Interface. SONIFI Solutions, Inc. proprietary protocol used for STB configuration/control via an MTI (typically labeled "DATA") port.

Pass-through Mode

The STB's factory default mode of operation. STBs can be configured for stand-alone use or as Master STBs for cloning purposes, and/or STBs may be controlled externally in this mode.

Physical Channel Number

The major channel number assigned to represent a specific 6 MHz RF band as specified by either the broadcast or CATV channel plan. See CEA (formerly EIA) or NCTA specifications for further information.

Pro:Centric Application

LG content delivery and communication interface, powered by an on-site Pro:Centric server or a Pro:Centric Cloud server that provides interactive entertainment, weather, amenities, etc. information for end users. Two application options are available: Pro:Centric Java application (on-site server only) or Pro:Centric Direct HTML application.

Pro:Centric Admin Client

Web editor/content wizard provided for service provider and customer configuration of Pro:Centric application and management elements. The proper Admin Client must be used in accordance with server type and licensed application.

Pro:Idiom

Zenith proprietary security software that unlocks access to premium content to help assure rapid, broad deployment of HDTV and other high-value digital content.

PTC

Protocol Translation Controller. The commercial controller (microprocessor) of the commercial STB.

Target STB

An STB to which a Master STB Setup will be transferred.

STB Setup Menus

Available via Installer Remote "MENU" key in Pass-through Mode only. Menus provide access to setup and functional features of the STB.

USB Memory Device

A USB flash drive or USB storage device, etc. that can be used for STB configuration purposes (typically cloning or FTG Mode via CPU configuration) or for updating STB software.

Virtual Channel Number

An alias (virtual) channel number provided in the data stream, by the broadcaster, of a digital broadcast channel to be displayed by consumer STBs in place of the physical channel number. The major number is the same as the original analog channel number and the minor number is the nth program available in that digital video stream.

Document Revision History / Open Source Software Notice

Document Revision History

Date	Description
August 2020	Revision A: New document
October 2020	Revision B: IP Environment / General Menu and TLT parameter updates
October 2020	Revision C: Default video output resolution update
March 2021	Revision D: Installer Menu updates
November 2021	Revision E: Installer Menu and PCC updates
December 2021	Revision F: Installer Menu updates (for PTC v1.00.015)
October 2022	Revision G: First Use Wizard, Installer Menu, IP Environment, and TLT updates
October 2022	Revision H: Installer Menu item 030 updates
March 2023	Revision I: Item 030, STB Quick Check, and CCT updates
September 2023	Revision J: External control and Installer Menu updates
March 2024	Revision K: Installer Menu and remote updates

Product documentation is available online at: www.lg.com/us/business.

Open Source Software Notice

To obtain the source code under GPL, LGPL, MPL and other open source licenses, that is contained in this product, please visit <http://opensource.lge.com>. In addition to the source code, all referenced license terms, warranty disclaimers and copyright notices are available for download. LG Electronics will also provide open source code to you on CD-ROM for a charge covering the cost of performing such distribution (such as the cost of media, shipping and handling) upon e-mail request to opensource@lge.com. This offer is valid for three (3) years from the date on which you purchased the product.



For Customer Support/Service, please call:

1-888-865-3026

www.lg.com/us/business

Pro:Idiom is a registered trademark of Zenith Electronics LLC. Pro:Centric, Smart Share, and the "LG" logo are registered trademarks of LG Electronics Inc. DLNA Certified is a registered trademark of Digital Living Network Alliance. Intel is a registered trademark of Intel Corporation in the U.S. and/or other countries. Wi-Fi Direct and Miracast are registered trademarks of Wi-Fi Alliance. All other trademarks or registered trademarks are the property of their respective owners.